

ROLLING PLAN

INTER-STATE TRANSMISSION SYSTEM

2027-28



March 2023
Central Transmission Utility

ROLLING PLAN 2027-28
INTER-STATE TRANSMISSION SYSTEM (ISTS)
(REPORT)

March 2023

Table of Contents

TABLE OF CONTENTS.....	I
LIST OF FIGURES.....	V
LIST OF TABLES	VII
EXECUTIVE SUMMARY	1
CHAPTER 1: BACKGROUND AND OBJECTIVE	5
CHAPTER 2: POWER SUPPLY SCENARIO	7
2.1 POWER SUPPLY SCENARIO AS ON FEB'23	9
2.2 ENVISAGED POWER SUPPLY SCENARIO BY 2027-28	10
CHAPTER 3: ALL INDIA ANALYSIS	13
3.1 LOAD GENERATION BALANCE.....	14
3.2 STUDY RESULTS AND ANALYSIS.....	21
3.2.1 Power Flow Analysis	21
3.2.2 Contingency Analysis.....	27
3.2.3 Short Circuit Analysis	31
3.3 ISTS EXPANSION UPTO 2027-28.....	33
3.3.1 Summary of ISTS network.....	33
3.3.2 Inter-Regional (IR) Capacity	34
CHAPTER 4: NORTHERN REGION.....	37
4.1 POWER SUPPLY SCENARIO AS ON FEB'23	37
4.2 ENVISAGED POWER SUPPLY SCENARIO BY 2027-28	37
4.3 LOAD GENERATION BALANCE FOR 2027-28 TIMEFRAME.....	39
4.4 ISTS NETWORK EXPANSION SCHEMES EVOLVED FROM MAR'22 TO FEB'23	40
4.4.1 Inter Regional/Other.....	40
4.4.2 Rajasthan	47
4.4.3 Punjab.....	57
4.4.4 Himachal Pradesh	63
4.4.5 Perspective transmission schemes under planning	67
4.5 MEASURES TAKEN FOR MITIGATION OF THE ISSUES OF ROLLING PLAN REPORT	68
4.5.1 Measures for controlling over-voltage.....	68
4.5.2 Measures for controlling short circuit	68
4.5.3 Measures for controlling loading of transformers and Transmission lines	68
4.6 SYSTEM STUDY ANALYSIS AND RESULTS FOR 2027-28 TIMEFRAME	69
4.6.1 Voltage Analysis.....	69
4.6.2 Short Circuit Analysis	70
4.6.3 Contingency Analysis.....	72
CHAPTER 5: WESTERN REGION	77
5.1 POWER SUPPLY SCENARIO AS ON FEB'23	77
5.2 ENVISAGED POWER SUPPLY SCENARIO BY 2027-28	77
5.3 LOAD GENERATION BALANCE FOR 2027-28 TIMEFRAME	79
5.4 ISTS NETWORK SCHEMES EVOLVED FROM MAR'22 TO FEB'23	80
5.4.1 Chhattisgarh	81
5.4.2 Maharashtra	83
5.4.3 Gujarat.....	92

5.4.4 Madhya Pradesh	104
5.5 MEASURES TAKEN FOR MITIGATION OF THE ISSUES OF PREVIOUS ROLLING PLANS	116
5.5.1 Measures for controlling overloading of Transmission lines and ICTs	116
5.5.2 Measures for controlling Short Circuit.....	117
5.5.3 Measures for controlling over-voltage.....	117
5.5.4 Mitigation of operational issues faced by JP Bina due to NHPTL testing.....	118
5.6 SYSTEM STUDY RESULTS AND ANALYSIS	121
5.6.1 Power Flow Studies	121
5.6.2 Voltage Analysis.....	121
5.6.3 Contingency Analysis.....	122
5.6.4 Short Circuit Analysis.....	125
CHAPTER 6: SOUTHERN REGION	129
6.1 POWER SUPPLY SCENARIO AS ON FEB'23	129
6.2 ENVISAGED POWER SUPPLY SCENARIO BY 2027-28	130
6.3 LOAD GENERATION BALANCE FOR 2027-28 TIMEFRAME.....	131
6.4 ISTS NETWORK EXPANSION SCHEMES EVOLVED FROM MAR'22 TO FEB'23	132
6.4.1 Karnataka	133
6.4.2 Tamil Nadu	141
6.4.3 Telangana	143
6.5 MEASURES TAKEN FOR MITIGATION OF ISSUES OF PREVIOUS ROLLING PLANS	146
6.5.1 Measures for controlling overloading of Transmission lines.....	146
6.5.2 Measures for controlling overloading of Transformers.....	148
6.5.3 Measures for controlling over-voltage.....	150
6.5.4 Measures for controlling Short Circuit.....	150
6.6 SYSTEM STUDIES RESULTS AND ANALYSIS	151
6.6.1 Power Flow Analysis	152
6.6.2 Contingency Analysis.....	154
6.6.3 Short Circuit Analysis.....	161
CHAPTER 7: EASTERN REGION	165
7.1 POWER SUPPLY SCENARIO AS ON FEB'23	165
7.2 ENVISAGED POWER SUPPLY SCENARIO BY 2027-28	165
7.3 LOAD GENERATION BALANCE FOR 2027-28 TIMEFRAME	166
7.4 ISTS NETWORK EXPANSION SCHEMES EVOLVED FROM MAR'22 TO FEB'23	168
7.4.1 Bihar	168
7.4.2 West Bengal	169
7.4.3 Jharkhand	171
7.4.4 Odisha.....	174
7.4.5 Sikkim.....	176
7.5 MEASURES TAKEN FOR MITIGATION OF THE ISSUES OF PREVIOUS ROLLING PLANS	177
7.5.1 Measures for Controlling Overloading of Transmission Lines.....	177
7.5.2 Measures for Controlling Overloading of ICTs.....	177
7.5.3 Measures for Controlling Fault level of Substations	178
7.6 SYSTEM STUDY RESULTS AND ANALYSIS	178
7.6.1 Power Flow Analysis	178
7.6.2 Contingency Analysis.....	180
7.6.3 Short Circuit Analysis.....	182
CHAPTER 8: NORTH EASTERN REGION	185

8.1 POWER SUPPLY SCENARIO AS ON FEB'23	185
8.2 ENVISAGED POWER SUPPLY SCENARIO BY 2027-28	185
8.3 LOAD GENERATION BALANCE FOR 2027-28 TIMEFRAME	186
8.4 ISTS NETWORK EXPANSION SCHEMES EVOLVED FROM MAR'22 TO FEB'23	187
8.4.1 Mizoram	188
8.4.2 Manipur	189
8.4.3 Meghalaya	190
8.4.4 Assam	192
8.5 MEASURES TAKEN FOR MITIGATION OF THE ISSUES OF PREVIOUS ROLLING PLANS	193
8.6 SYSTEM STUDY RESULTS AND ANALYSIS	193
8.6.1 Power Flow Analysis	193
8.6.2 Contingency Analysis	194
8.6.3 Short Circuit Analysis	195
CHAPTER 9: CROSS-BORDER INTERCONNECTION	197
9.1 INDIA-BANGLADESH	197
9.2 INDIA-BHUTAN	197
9.3 INDIA-MYANMAR	198
9.4 INDIA-NEPAL	198
9.5 INDIA-SRI LANKA	199
CHAPTER 10: PLANNING UNDER GENERAL NETWORK ACCESS (GNA)	201
10.1 BACKGROUND	201
10.2 INTRODUCTION	201
10.3 SYSTEM STUDY IN GNA	202
10.4 PROCEDURE FOR SYSTEM STUDIES	203
10.5 TRANSITION UNDER GNA	205
CHAPTER 11: CONCLUSION	209
Annexures	217

Page intentionally left blank

List of Figures

Figure 2-1: Installed Electricity Generation Capacity Trend in India.....	8
Figure 2-2: Installed Capacity & Demand trend.....	9
Figure 2-3: Installed Capacity and Peak Demand as on Feb'23	10
Figure 2-4: Projected Installed Capacity & Peak Demand by FY 2027-28	11
Figure 3-1: India's map showing various generations in different parts of the country	13
Figure 3-2: Summer (June'21) Load Curve.....	15
Figure 3-3: Monsoon (Aug'21) Load Curve	15
Figure 3-4: Winter (Feb'22) Load Curve	15
Figure 3-5: Demand factors considered for 2027-28-time frame	16
Figure 3-6: Generation surplus in GW with Tech Min (55%) for Thermal Units	17
Figure 3-7: Generation surplus in GW with Tech Min (40%) for Thermal Units	18
Figure 3-8: LGB for Monsoon Aug'2027	19
Figure 3-9: LGB for Summer June'2027.....	19
Figure 3-10: LGB for Winter Feb'2028	20
Figure 3-11: 765kV Tr. line flow > 70% of thermal limit under base case	23
Figure 3-12: 400kV Tr. line flow > 70% of thermal limit under base case	24
Figure 3-13: 765/400kV ICT Loading under base case	25
Figure 3-14: 400/220kV ICT loading under Base Case.....	25
Figure 3-15: Voltage Profile of 765 KV & 400 KV buses	26
Figure 3-16: 765kV Tr. line loadings>3000MW under N-1 Contingency	27
Figure 3-17: 765kV line loading>3200 MW under N-1 Contingency.....	27
Figure 3-18: 765kV line loading>3500 MW under N-1 Contingency.....	28
Figure 3-19: 400kV line loading>90% of thermal limit under N-1 Contingency.....	28
Figure 3-20: 400kV line loading>thermal limit under N-1 Contingency	29
Figure 3-21: 765/400kV ICT loading \geq 90% of MVA rating under N-1 Contingency	29
Figure 3-22: 765/400kV ICT loading \geq 100% of MVA rating under N-1 Contingency	30
Figure 3-23: 400/220kV ICT loadings \geq 90% of MVA rating under N-1 Contingency.....	30
Figure 3-24: 400/220kV ICT loadings \geq 100% of MVA rating under N-1 Contingency.....	31
Figure 3-25: Short circuit level 765 kV and 400 kV buses on pan India basis.....	32
Figure 3-26: Violation of fault level at ISTS/STU/Gen buses at 765 kV and 400 kV levels	32
Figure 3-27: Growth in IR Capacity	35
Figure 3-28: Inter-Regional Transmission Capacity by 2027-28	35
Figure 4-1: Tr. Scheme to relieve high loading of WR-NR IR Corridor	42
Figure 4-2: Maximum MVA injection on a typical night.....	44
Figure 4-3: Total MVA flow from 220 kV to 400 kV through 400/220 kV ICTs	44
Figure 4-4: Tr. system for evacuation of power from Rajasthan REZ Ph-IV (Part-1)	50
Figure 4-5: Tr. system for evacuation of power from Rajasthan REZ Ph-IV (Part-2)	57
Figure 4-6: Loading of Patran ICTs (2x500 MVA).....	58
Figure 4-7: Schematic of 400/220kV Patran (GIS) S/s.....	59
Figure 4-8: Schematic of 400/220kV Panchkula (S/s).....	60
Figure 4-9: Loading of Ludhiana ICTs (1630MVA)	61
Figure 4-10: Schematic of 400/220kV Ludhiana S/s.....	62
Figure 4-11: Loading of Moga ICTs (1565MVA).....	62
Figure 4-12: Schematic of 765/400/220kV Moga S/s.....	63
Figure 4-13: Tr. system for evacuation of power from Shongtong) and Tidong HEP.....	67
Figure 5-1: Augmentation of 1x500 MVA, 400/220kV ICT (3rd) at Raigarh (PG) S/s	82

Figure 5-2: Western Region Expansion Scheme-XXIV (WRES-XXIV).....	83
Figure 5-3: Western Region Expansion Scheme-XXX (WRES-XXX).....	85
Figure 5-4: Western Region Expansion Scheme XXXI (WRES-XXXI): Part A.....	87
Figure 5-5: Tr. system for evacuation of power from RE projects in Solapur SEZ.....	92
Figure 5-6: Tr. system for Evacuation of Power Khavda REZ.....	100
Figure 5-7: Scheme for drawal of 4000 MW power by MPSEZ.....	102
Figure 5-8: Implementation of 1 no. 220kV line bay at Bhuj PS for NTPC REL.....	103
Figure 5-9: Western Region Expansion Scheme XXXIII.....	105
Figure 5-10: Western Region Expansion Scheme XXXIII: Part B.....	107
Figure 5-11: Western Region Expansion Scheme XXXIII: Part C.....	110
Figure 5-12: Western Region Expansion Scheme XXXIII: Part D.....	111
Figure 5-13: Transmission scheme for evacuation of power from Neemuch WEZ.....	113
Figure 5-14: Transmission System for Rajgarh SEZ Phase-II.....	114
Figure 5-15: Transmission System for VEH Jayin at Rajgarh (PG) S/s.....	116
Figure 5-16: Network interconnection of JP Bina.....	118
Figure 5-17: Power Output of Jaypee Bina for Case-1.....	119
Figure 5-18: Power Output of Jaypee Bina for Case-2.....	120
Figure 5-19: Power Output of Jaypee Bina for Case-3.....	120
Figure 5-20: Power Output of Jaypee Bina for Case-4.....	121
Figure 5-21: Substations crossing the design limit in WR at 400kV buses.....	126
Figure 6-1: Augmentation of 1x500 MVA, 400/220kV ICT (6 th) at Pavagada (Tumkur) PS.....	134
Figure 6-2: Augmentation of 1X500 MVA, 400/220kV ICT (4 th) ICT at Mysore S/s.....	138
Figure 6-3: Augmentation of 1x500 MVA, 400/230kV ICT at Arasur S/s.....	142
Figure 6-4: Augmentation of 1x500 MVA, 400/230kV ICT at Hosur S/s.....	143
Figure 6-5: Augmentation of 1x1500 MVA, 765/400kV /ICT at Maheshwaram(PG).....	144
Figure 6-6: Substations crossing the design limit in SR.....	162
Figure 7-1: Proposed new 400kV substation in DVC area.....	173
Figure 9-1: Cross-Border interconnections.....	200
Figure 10-1: Planning under Connectivity regulations 2009.....	201
Figure 10-2: Planning under GNA Regulations 2022.....	201
Figure 10-3: Depiction of GNA within and outside the region.....	203
Figure 10-4: Distribution of quantum of generation.....	206
Figure 10-5: Conversion of quantum of generation in GNA.....	207
Figure 10-6: Break up of total generation for transition under GNA.....	207

List of Tables

Table 2-1: Installed Electricity Generation Capacity	7
Table 2-2: Increment in IC over the years	8
Table 2-3: Installed Capacity and Peak Demand as on Feb'23	9
Table 2-4: Projected Installed Capacity & Peak Demand by FY 2027-28	10
Table 2-5: Generation IC & Peak demand in 2022-23 and 2027-28	11
Table 3-1: Regional Surplus/Deficit summary	20
Table 3-2: IR flow summary	21
Table 3-3: Maximum violation of fault level at ISTS/STU/GEN buses	32
Table 3-4: Under Construction Transmission lines (in ckm)	33
Table 3-5: Under Construction Transformation Capacity (in MVA)	33
Table 3-6: Broad estimated cost (in ₹ Cr.) (Under Construction).....	33
Table 3-7: Under planning/bidding/approval Transmission lines (in ckm)	34
Table 3-8: Under planning/bidding/approval Transformation Capacity (in MVA).....	34
Table 3-9: Broad estimated cost (in ₹ Cr.) (under planning/bidding/approval).....	34
Table 4-1: Installed Capacity and Peak Demand of NR as on Feb'23	37
Table 4-2: Northern Region Installed Capacity and peak demand (2027-28)	38
Table 4-3: Increase in Peak Demand of Various States of NR	38
Table 4-4: Northern Region Generation Dispatch and Demand Factors	39
Table 4-5: IR Flows & Surplus/Deficit (Northern Region)	39
Table 4-6: Substations having high voltage in NR	69
Table 4-7: ISTS Buses Exceeding Designed Fault Level (1.2pu) in NR.....	70
Table 4-8: STU Buses Exceeding Designed Fault Level (1.2pu) in NR.....	71
Table 4-9: Major transmission lines having critical loading in NR	72
Table 4-10: Major transformers having critical loading in NR.....	73
Table 5-1: All India Installed Capacity and Demand met as on Feb'23	77
Table 5-2: Western Region Installed Capacity and Peak Demand (2027-28)	78
Table 5-3: State-wise Demand Growth in Western Region.....	78
Table 5-4: Western Region Generation Dispatch and Demand Factors	79
Table 5-5: Drawl of various states from ISTS grid.....	79
Table 5-6: Details of the schemes evolved in WR.....	80
Table 5-7: Buses having more than 1.05 pu Voltage in WR	122
Table 5-8: 765kV ISTS Transmission lines not meeting N-1 Criteria in WR	122
Table 5-9: 400kV Transmission lines not meeting N-1 Criteria in WR	123
Table 5-10: ISTS ICTs not meeting N-1 Criteria in WR	124
Table 5-11: STU ICTs not meeting N-1 Criteria in WR.....	125
Table 5-12: ISTS Buses Exceeding Designed Fault Level in WR.....	126
Table 5-13: STU Buses Exceeding Designed Fault Level in WR	127
Table 5-14: Generator Buses Exceeding Designed Fault Level in WR.....	127
Table 6-1: Installed Capacity and Peak Demand of SR as on Feb'23	129
Table 6-2: Southern Region Installed Capacity and peak demand (2027-28)	130
Table 6-3: Increase in Peak Demand of Various States of SR.....	130
Table 6-4: Southern Region Generation Dispatch and Demand Factors	131
Table 6-5: Surplus/Deficit of Southern Region	131
Table 6-6: Details of the schemes evolved in SR	132
Table 6-7: Transmission Lines Loading in the Base Cases	152
Table 6-8: Transformers Loading in the Base Cases	153

Table 6-9: Buses having more than 1.05 pu Voltage in SR	153
Table 6-10: ISTS Transmission lines not meeting N-1 Criteria in SR	155
Table 6-11: STU Transmission lines not meeting N-1 Criteria in SR	157
Table 6-12: ISTS ICTs not meeting N-1 Criteria in SR.....	159
Table 6-13: STU ICTs not meeting N-1 Criteria in SR	159
Table 6-14: ISTS Buses Exceeding Designed Fault Level in SR	162
Table 6-15: STU Buses Exceeding Designed Fault Level in SR.....	163
Table 7-1: Installed Capacity and Peak Demand of ER as on Feb'23	165
Table 7-2: Eastern Region Installed Capacity and Peak Demand (2027-28).....	166
Table 7-3: Increase in Peak Demand of Various States of ER	166
Table 7-4: Eastern Region Generation Dispatch and Demand Factors.....	167
Table 7-5: Import / Export of Eastern Region	167
Table 7-6: Approved Transmission Schemes in this Rollnig Plan	168
Table 7-7: Transmission Lines Loading in the Base Cases	178
Table 7-8: Transformers Loading in the Base Cases	179
Table 7-9: ISTS Transmission lines not meeting N-1 Criteria in ER	180
Table 7-10: ISTS ICTs not meeting N-1 Criteria in ER	181
Table 7-11: STU ICTs not meeting N-1 Criteria in ER.....	181
Table 7-12: ISTS Buses Exceeding Designed Fault Level in ER.....	182
Table 7-13: STU Buses Exceeding Designed Fault Level in ER.....	183
Table 8-1: Installed Capacity and Peak Demand of NER as on Feb'23	185
Table 8-2: North Eastern Region Installed Capacity and peak demand (2027-28).....	186
Table 8-3: Increase in Peak Demand of Various States of NER.....	186
Table 8-4: North Eastern Region Generation Dispatch and Demand Factors	187
Table 8-5: Import / Export of North Eastern Region	187
Table 8-6: Approved Transmission Schemes in this Rolling Plan	188
Table 8-7: Transmission Lines Loading in the Base Cases	194
Table 8-8: STU Transmission lines not meeting N-1 Criteria in NER.....	195
Table 9-1: Cross-border power transfer capacity by 2027-28	199

Executive Summary

India is steadily moving towards a 5 trillion USD economy with thrust on high economic activity in the country. Electricity sector is one of the major growth engines of this high economic activity by providing secure and reliable network for power evacuation from large generation complexes to all the major load centres of the country. In order to meet the growing power and energy demand in sustainable and eco-friendly manner, India is going through a phase of energy transition at rapid pace with greater focus on development of new Renewable Energy (RE) resources. In this direction, at the COP26 climate conference in Glasgow, India has committed to achieve non-fossil energy capacity of 500GW by 2030 and to meet 50 per cent of its energy requirement through RE by 2030. Further, India has also set target of being a net zero emitter by 2070.

There is a continuous strong growth in demand for electricity in the country. The emerging utilisations of electricity today is observed in the transportation sector to reduce emission of greenhouse gases. Govt. of India came up with Green Hydrogen Policy in Feb 2022 and National Green Hydrogen Mission in January 2023, and it is expected that there is going to be power requirement in the National Grid to the tune of 125GW from industries producing Green Hydrogen and Green Ammonia using power from Renewable Energy (RE) resources. ISTS planning has been initiated in this direction too, so as to provide requisite power to such industries from large RE complexes.

In order to achieve the energy transition goals and facilitate large scale integration of RE, Central Electricity Authority (CEA) published a Report titled *“Transmission System for Integration of over 500MW RE Capacity by 2030”* in Dec 2022 inter alia including details of the transmission requirement for RE integration till 2030, energy storage requirement in the grid, new HVDCs requirement etc. Also keeping pace with latest international best practices in transmission planning, CEA has updated and came up with *“Manual on Transmission Planning Criteria, 2023”*.

The huge quantum of RE generations being integrated in the National Grid to meet the energy transition goals, needs to be transferred reliably and securely to all the major load centres of the country. This necessitates continuous development of a robust National Grid comprising of high capacity AC and HVDC systems along with state-of-the-art FACTS devices for controlling power system parameters. India’s path and ways of RE integration to its National Grid can act as blue print for other countries for development of new age electricity grid. There is also a thrust on development and integration of Energy Storage devices in form of batteries, pumped hydro etc. in the National Grid, for providing balancing power during low or no RE period and also increasing utilisation of transmission system associated with RE projects.

Transmission system plays a very crucial role of facilitating integration of generation resources and demand centres to the National Grid, and therefore should be planned and developed adequately so as to enable seamless integration of generation projects and also facilitate availability of reliable, secure, and affordable power to all the consumers.

In this direction, and as per Electricity (Transmission System Planning, Development and Recovery of Inter-State Transmission Charges) Rules, 2021, notified by Ministry of Power, Govt. of India, CTU has been publishing the ISTS Rolling Plan Reports on half-yearly basis (Interim Report in Sept and Final Report in March of every financial year) with last one being published on 30th Sept 2022. This ISTS Rolling Plan Report has been prepared to assess transmission system adequacy in ISTS for 2027-28 time-frame taking due consideration of “Transmission System for Integration of over 500MW RE Capacity by 2030” report.

Chapter-1 gives Background and Objectives of the ISTS Rolling Plan Report.

In **Chapter-2**, installed capacity & peak demand as on Feb’23 and projected installed capacity & demand by FY 2027-28 have been presented. All India installed capacity & peak demand are expected to increase from 412GW (including about 122GW RE + 47GW Hydro) & 215 GW respectively as on Feb’23 to about 702GW (including about 336GW RE + 63GW Hydro + 28.5GW ESS) & 294GW respectively by FY 2027-28.

In order to integrate the envisaged generation capacity, predominantly RE, and to meet the projected demand, comprehensive studies have been performed on the National Grid on All India and Regional basis for planning and development of Inter-State Transmission System (ISTS). To perform the studies, Load Generation Balance (LGB) has been prepared considering the diurnal and seasonal load and generation variations across the country. Accordingly, nine number of load-generation scenarios have been identified corresponding to Monsoon, Summer, and Winter seasons along with three points on daily load curve for each season viz. Solar max, Peak demand, and Off-peak demand.

Detailed overview of the load generation balance preparation and challenges observed while balancing the same and study results have been brought out in **Chapter-3**. While preparing LGB for nine scenarios, merit order economic dispatch of thermal generations and RPO obligations of states have been taken into consideration. Maximum and minimum demand of 314GW and 161GW respectively have been considered in 2027-28 timeframe while working out the LGBs. ESS Charging has been considered as load in Solar Max scenarios and during discharging as Generation in other scenarios.

Detailed system studies have been carried out for nine scenarios - after considering all the planned and under construction system, in line with provisions under CEA’s Manual on Transmission Planning Criteria. Due to intermittent and variable nature of RE and with high penetration of RE in the Indian Grid, loading pattern on some of the lines is expected to change diurnally as well as seasonally. Further, transmission lines associated with thermal and hydro generations would be lightly loaded during high RE scenario. In the **Chapter-3**, study results have been presented for All India grid (above 400kV) including critically loaded lines & transformers under normal & N-1 condition, voltage violations, short circuit violations etc. Network expansion schemes have been planned and being planned to take care of the observed system violations. Accordingly, year on year progressive addition of transmission system in ISTS network in terms of new transmission lines (ckm) and substations (MVA) upto 2027-28, and its corresponding broad estimated cost has also been brought out in the report.

Cumulatively by 2027-28, transmission schemes comprising of 41,255 ckm of transmission lines and transformation capacity of 3,84,925 MVA at estimated cost of Rs 2,23,954 Cr. is expected to be added in the grid.

The Inter-Regional (IR) transmission capacity is expected to grow from present level of 1,12,250 MW to about 1,38,740MW by 2027-28. Due to diurnal and seasonal variation in RE generation, power flow on all IR corridors is observed in both directions. Maximum change is observed in WR→NR corridor, where power of the order of 20GW is flowing from WR to NR in summer evening peak scenario and power of the order of 12GW is flowing from NR to WR in winter solar max scenario. New high capacity links in WR-SR, WR-NR, and WR-ER corridors are under various stages of Implementation to cater the increased inter-regional power transfer.

Chapter-4 to Chapter-8 are dedicated to detailed study results pertaining to each of the five regions, i.e. one Chapter for each Region. State wise LGBs have been prepared for all the regional grids for nine load-generation scenarios and outcomes of study results have been brought out. Critically loaded lines & transformers under normal & N-1 condition, voltage violations, short circuit violations etc. have been reported in both ISTS and STU network and possible reasons/cause for the same are also brought out in respective regional chapters. Further, detailed scope of works and implementation time-frame along with schematic of new ISTS schemes including schemes for RE evacuation for mitigating some of these violations have been brought out in these Chapters. For remaining violations, additional expansion schemes in ISTS are being planned after detailed studies, and accordingly the details of the same would be brought out in the subsequent Rolling Plan reports. In order to meet the drawl requirement of potential Green Hydrogen and Green Ammonia based industries in Paradeep area in the state of Odisha, a new 765/400kV substation has been planned under ISTS.

India being centrally placed in South Asia is playing a vital role in establishment of interconnections between countries so as to establish a large South Asian electricity grid. In **Chapter-9**, details on existing, under-construction and under discussion cross-border interconnections between India and neighbouring countries have been brought out.

Central Electricity Regulatory Commissioning (CERC) has issued CERC (Connectivity and General Network Access to the inter-State Transmission System) Regulations, 2022. In **Chapter-10**, key highlights of the GNA Regulations have been provided along with brief details of procedure for system studies for ISTS planning, which would be taken up in order to cater to Connectivity and GNA requirements of various stakeholders including Generations, STUs, Bulk consumers, Distribution licensees etc.

The summary of the studies carried out, new expansion schemes planned, way forward etc. have been mentioned in **Chapter-11**.

Page intentionally left blank

Chapter 1: Background and Objective

India envisaged to enhance the Non-Fossil fuel based installed generation capacity to 500 GW and about 50% Non-Fossil share of installed electricity generation capacity by 2030. During the current study time-frame i.e., by 2027-28, it is proposed to add about 400 GW RE (including Hydro) which is more than 50% (i.e. 57%) of the installed capacity.

Large-scale integration of Renewable-based Generation capacity into the Grid poses many challenges like low-capacity utilization factor (CUF), intermittency, round the clock availability etc. Preparation of Load Generation Balance considering the diurnal and seasonal variation across the country with fair assumptions is the key to plan an optimised ISTS Transmission Network for Integration and evacuation of RE generation. Further, to address the intermittency aspect of RE generation, Energy Storage Devices such as (BESS, Pumped Storage Plant etc.) and adequate reactive compensation (including Dynamic Compensation) are also to be integrated to make the Grid Resilient and to enhance the voltage stability of the Grid.

Considering the short gestation period of the RE Generation, corresponding Inter State Transmission System (ISTS) is to be made in place for smooth evacuation of the integrated RE generation for which advance planning of ISTS is done considering the inputs from all the stakeholders.

In line with the Ministry of Power Rules, 2021 published vide gazette notification dated 1st Oct 2021, CTU is drawing up plan for Inter-State Transmission System (ISTS) for up to next five years on Rolling basis every year, involving two cycles i.e., from April to September and October to March identifying specific transmission projects which are required to be taken up along with their implementation time lines. In this direction, reports on Network Plan 2024-25, Rolling Plan 2026-2027 & Interim Rolling Plan 2027-28 has already been brought out on 31st Dec 2021, 31st March 2022 & 30th Sep 2022 respectively and the same is available on CTU website. This ISTS Rolling Plan report is brought out identifying adequacy of transmission system in ISTS for 2027-28 time-frame.

This report covers year wise ISTS planned and under implementation across the country to integrate the RE generation and also to cater the growing demand. Detailed studies were carried out on the planned Transmission system including load flow, contingency analysis, voltage profile (reactive power management), short circuit studies etc on all India basis for 2027-28 timeframe for nine perspective load-generation scenarios covering three seasons and three different load condition (Solar max, evening peak and night off peak) of each season.

Page intentionally left blank

Chapter 2: Power Supply Scenario

A robust National Grid was planned and implemented in the last decade to take care of power flow pattern considering the growth in installed capacity with majority of generation from thermal-based plants and peak demand. Increase in the installed generation capacity in GW over the years from 2013-14 to 2021-22 is mentioned in **Table 2-1**. Further, increasing trend of RE capacity in total installed capacity mix is also stated in Table 2-1 & depicted in

Table 2-1: Installed Electricity Generation Capacity

Year	Thermal	Hydro	Nuclear	RES	Total	RES/TOTAL IC
2013-14	168.26	40.53	4.78	34.99	248.55	14%
2014-15	188.9	41.27	5.78	38.96	274.9	14%
2015-16	210.68	42.78	5.78	45.92	305.16	15%
2016-17	218.33	44.48	6.78	57.24	326.83	18%
2017-18	222.91	45.29	6.78	69.02	344	20%
2018-19	226.28	45.4	6.78	77.64	356.1	22%
2019-20	230.81	45.7	6.78	86.76	370.05	23%
2020-21	234.73	46.21	6.78	94.43	382.15	25%
2021-22	236.11	46.72	6.78	109.89	399.5	28%

* Source: Report on Short-Term Power Market in India: 2020-21

Figure 2-1. Renewables-based generation capacity witnessed an increase from 14% to 28% of total Installed Capacity (IC) from FY 2013-14 to 2021-22 respectively.

Table 2-1: Installed Electricity Generation Capacity

(All Fig in GW)

Year	Thermal	Hydro	Nuclear	RES	Total	RES/TOTAL IC
2013-14	168.26	40.53	4.78	34.99	248.55	14%
2014-15	188.9	41.27	5.78	38.96	274.9	14%
2015-16	210.68	42.78	5.78	45.92	305.16	15%
2016-17	218.33	44.48	6.78	57.24	326.83	18%
2017-18	222.91	45.29	6.78	69.02	344	20%
2018-19	226.28	45.4	6.78	77.64	356.1	22%
2019-20	230.81	45.7	6.78	86.76	370.05	23%
2020-21	234.73	46.21	6.78	94.43	382.15	25%
2021-22	236.11	46.72	6.78	109.89	399.5	28%

* Source: Report on Short-Term Power Market in India: 2020-21

Figure 2-1: Installed Electricity Generation Capacity Trend in India

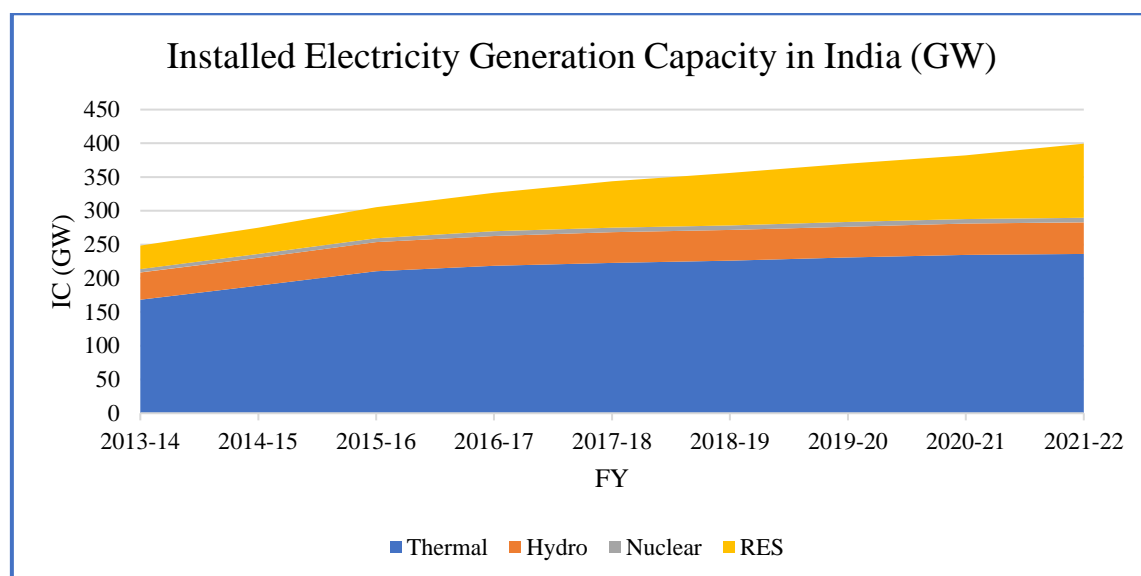

However, if we see the contribution to total capacity addition, it is seen that there is a definite change in generation addition profile. As it can be seen from Table 2-2 that in overall generation addition over the years, contribution from thermal generation addition has seen a decline whereas, Addition in share of RES to the total IC has witnessed a significant increase. RE capacity addition has increased from 15% to 89% in FY 2014-15 to FY 2021-22 respectively highlighting the transition of Indian power sector towards clean energy resources. This change in generation addition profile is expected to continue in India.

Table 2-2: Increment in IC over the years

(All Fig in GW)

Year	Thermal	Hydro	Nuclear	RES	Total	RES/TOTAL IC
2014-15	20.64	0.74	1	3.97	26.35	15%
2015-16	21.78	1.51	0	6.96	30.25	23%
2016-17	7.65	1.7	1	11.32	21.67	52%
2017-18	4.58	0.81	0	11.78	17.17	69%
2018-19	3.37	0.11	0	8.62	12.1	71%
2019-20	4.53	0.3	0	9.12	13.95	65%
2020-21	3.92	0.51	0	7.67	12.1	63%
2021-22	1.38	0.51	0	15.46	17.35	89%

Similarly, India's peak demand has substantially increased from 148 GW in 2014-15 to 215 GW as on Feb'23. As per 20th EPS, the anticipated peak demand is expected to increase to about 294 GW by 2027-28. To meet this fast-growing demand, generation capacity is also being continuously added into the grid, which is expected to be about 702 GW by 2027-28 from 412 GW as of Feb'23. Furthermore, presently RES excluding hydro generation is contributing around 122 GW (30% of installed capacity) which will increase to around 336

GW (48% of installed capacity) by 2027-28, with a CAGR of 22.5%. Installed capacity vis a vis demand trend from FY 2014-15 to FY 2027-28 are shown in **Figure 2-2**.

Figure 2-2: Installed Capacity & Demand trend

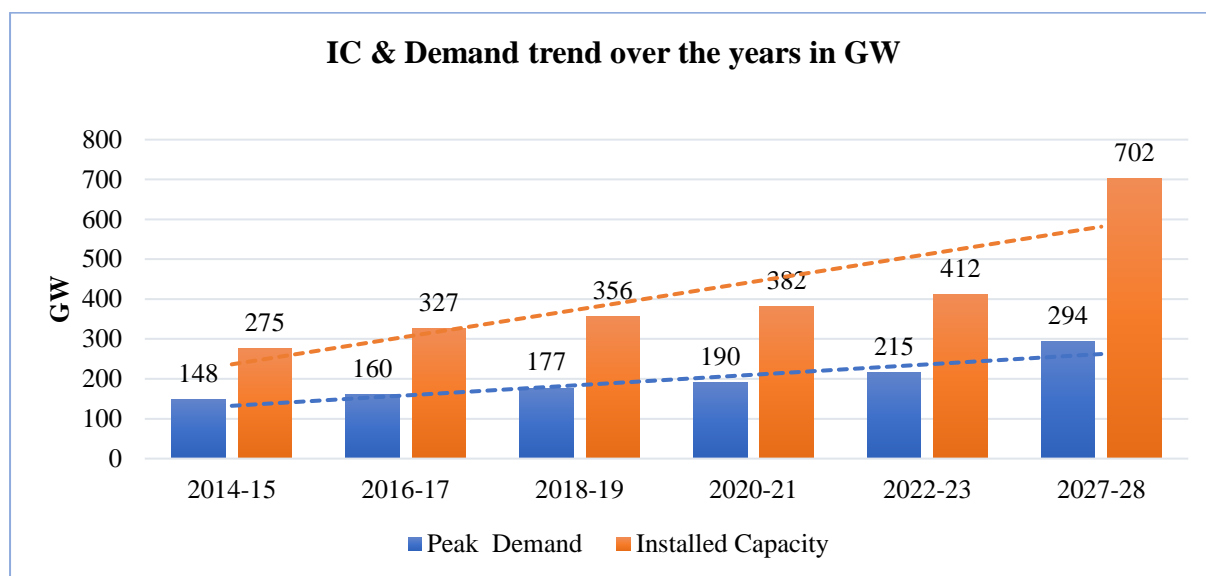

*2022-23 Peak demand & IC are as on Feb'23

2.1 Power Supply Scenario as on Feb'23

The total installed capacity as on Feb'23 was about 412 GW as against peak demand of about 215 GW. The region-wise breakup for the source wise installed capacity and peak demand as on Feb'23 is given in the Table 2-3. Presently, thermal-based generation accounts for 57% and Renewable-based generation accounts for 30% of total installed generation capacity, which is portrayed in **Figure 2-3**.

Table 2-3: Installed Capacity and Peak Demand as on Feb'23

(All Fig in GW)

Region	Fossil			Non-Fossil				Grand Total	Peak Demand
	Thermal	Gas	Total	Nuclear	Hydro	RES	Total		
NR	56.9	5.8	62.7	1.6	20.8	31.8	54.2	116.9	77.34
WR	76.0	10.8	86.8	1.8	7.6	38.1	47.5	134.3	71.68
SR	50.3	6.5	56.8	3.3	11.8	49.9	65.0	121.8	61.12
ER	27.7	0.1	27.8	0.0	4.8	1.8	6.6	34.3	28.27
NER	0.6	1.7	2.3	0.0	1.9	0.5	2.5	4.8	3.60
All India	211.5	24.8	236.3	6.8	46.8	122.1	175.7	412.1	215.88

Figure 2-3: Installed Capacity and Peak Demand as on Feb '23

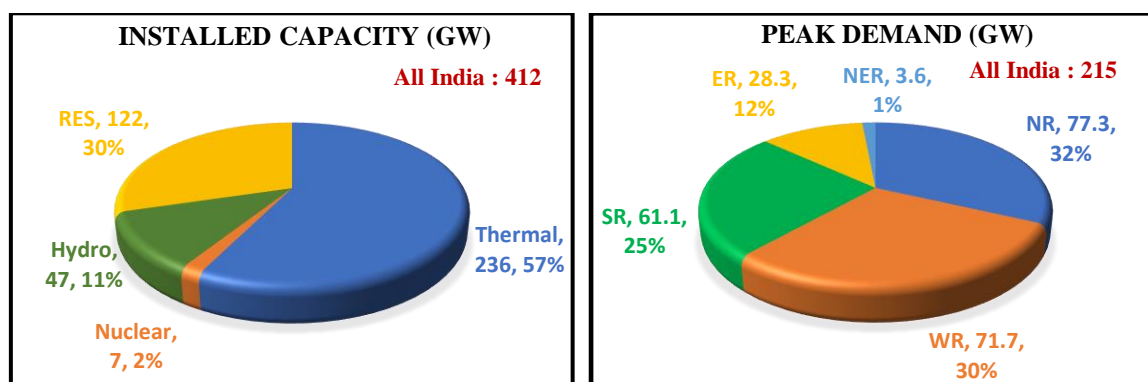

2.2 Envisaged Power Supply Scenario by 2027-28

All India peak demand for 2027-28 is envisaged to be about 294 GW as per 20th Electric Power Survey (EPS) report of CEA. To meet 78 GW increase in demand from present peak demand of 215 GW, net generation capacity of about 290 GW is envisaged to be added after considering the retirement of thermal generation by 2027-28 as anticipated in draft National Electricity Plan (NEP) of CEA. Total installed capacity for 2027-28 shall be about 702 GW including the pumped hydro and energy storage capacity as per report “Transmission System for Integration of 500 GW RE Capacity by 2030”. The anticipated region-wise breakup for the installed capacity and projected peak demand for 2027-28 are mentioned in **Table 2-4**. Renewable-based installed capacity is expected to be about 50% of total installed generation capacity, which is shown in **Figure 2-3**.

Table 2-4: Projected Installed Capacity & Peak Demand by FY 2027-28

(All Fig in GW)

Region	Fossil			Non-Fossil				ESS	Grand Total	Peak Demand
	Thermal	Gas	Total	Nuclear	Hydro	RES	Total			
NR	53.7	3.6	57.3	4.4	25.3	105.6	135.3	7.5	200.1	103.7
WR	88.8	10.1	98.9	3.2	6.3	95.5	105.1	3.3	207.3	94.7
SR	54.5	1.8	56.3	7.8	13.2	133.6	154.7	16.8	227.8	86.0
ER	44.4	0.0	44.4	0.0	13.8	1.5	15.3	0.9	60.5	39.8
NER	0.8	1.9	2.6	0.0	4.4	0.2	4.6	0.0	7.2	5.2
All India	242.1	17.4	259.4	15.5	63.0	336.4	414.9	28.5	702.9	294.7

Figure 2-4: Projected Installed Capacity & Peak Demand by FY 2027-28

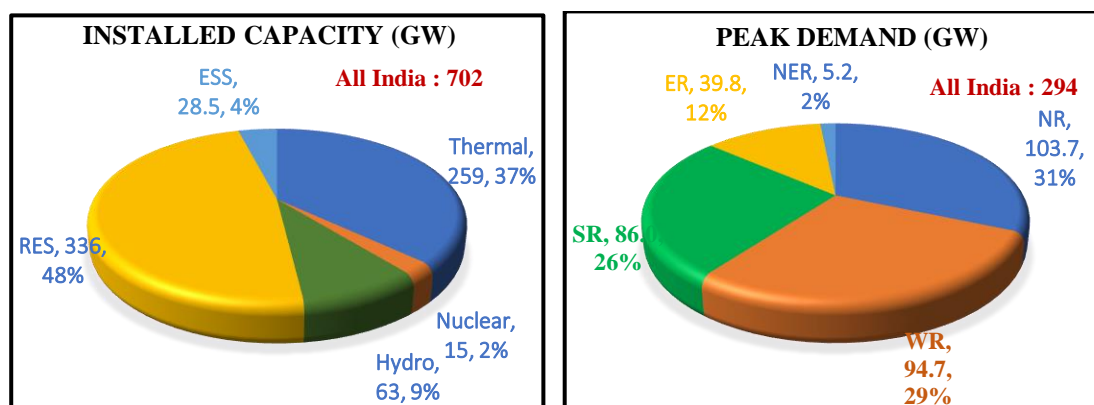

The region wise growth in demand and fuel type wise increase in installed generation capacity for 2027-28 from present time-frame is tabulated below in Error! Reference source not found.

Table 2-5

Table 2-5: Generation IC & Peak demand in 2022-23 and 2027-28

	Generation IC (GW)				Peak Demand (GW)				
	Feb'23	2027-28	Diff	CAGR	Feb'23	2027-28	Increment	CAGR	
Thermal	211.05	242.09	31.03	2.78%	NR	77.3	103.65	26.3	6.03%
Gas	24.82	17.36	-7.47	-6.91%	WR	71.7	94.75	23.1	5.74%
Nuclear	6.78	15.48	8.70	17.95%	SR	61.1	85.95	24.8	7.06%
Hydro/ESS	46.85	91.46	44.61	14.32%	ER	28.3	39.85	11.6	7.11%
Solar	64.38	230.35	165.97	29.04%	NER	3.6	5.16	1.6	7.46%
Other RE	58.16	106.09	47.93	12.77%	All India	215.9	294.72	78.84	6.42%
Total	412.05	702.83	290.77	11.27%					

Page intentionally left blank

Chapter 3: All India Analysis

Renewable-based generation share in total installed capacity is expected to change from 30% at present to about 48% by the year 2027-28. Further, it is going to continuously change with integration of increasing renewable energy plants in the Indian power sector. To plan transmission network for meeting electricity requirement of the country, first it is important to understand the locations of generation pockets and load centre in wide Indian demography. Most of the conventional thermal generation are located in eastern part of the India due to availability of coal-reserves and hydro-potential is concentrated in Himalayan Ranges whereas, new generation addition in the form of renewable energy is emerging in northern, western and southern part of India as depicted in **Figure 3-1** which makes Indian power sector one of the most challenging and diversified. To meet energy demand of the country from conventional generation, strong backbone transmission system is already planned and implemented in past decade. With the advent of renewable-based generation addition, power flow pattern on existing transmission system are changing. It becomes important to understand diurnal and seasonal regional exchanges taking place depending upon the generation and demand of a region. Therefore, any additional transmission system needs to be planned to cater the new load-generation scenario.

Figure 3-1: India's map showing various generations in different parts of the country

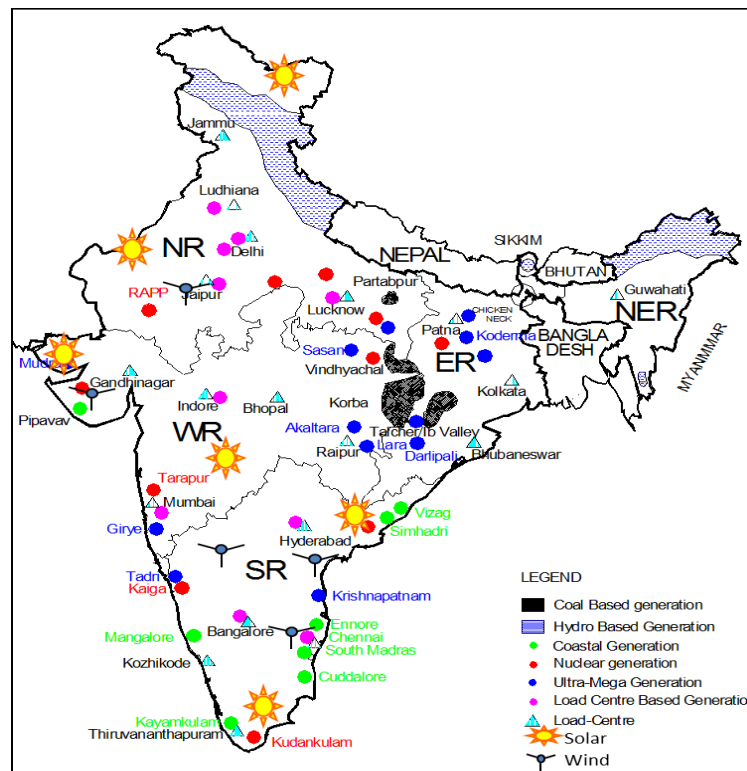

The present study has been carried out to identify adequacy of existing, approved and planned transmission systems to meet the power transfer requirement till the time-frame of 2027-28 with an all India perspective, highlighting the challenges if any and possible solution to carry out periodic assessment of transmission requirement under ISTS. Here it is to mention that substantial solar generation capacity addition has been envisaged in future which shall only

generate in day time. A region having a high solar installed capacity shall have surplus power during afternoon and power during evening.

To study such phenomenon and analyse power flow patterns in transmission network, various scenarios were identified. Accordingly, nine load generation balance scenarios were prepared corresponding to Monsoon, Summer and Winter season along with three points on daily load curve for each season. Details about the same are discussed in next section.

3.1 Load Generation Balance

To replicate and simulate seasonal power requirement variations on annual basis, three load-generation scenarios within a day in three different seasons were chosen. Three points on load curves were identified for each day i.e. Solar max (afternoon), Peak load (evening) and Off-peak load (night). Further, the same was carried out for three seasons viz. Monsoon (August), Summer (June) and Winter (February). Accordingly, load generation has been prepared for following nine scenarios:

- Aug'27: Solar max (Scenario-1), Evening Peak (Scenario-2) and Night off-peak (Scenario-3)
- Jun'27: Solar max (Scenario-4), Evening Peak (Scenario-5) and Night off-peak (Scenario-6)
- Feb'28: Solar max (Scenario-7), Evening Peak (Scenario-8) and Night off-peak (Scenario-9)

During afternoon hours, solar generation is at its peak and thermal generation requirement is minimal. While in evening, solar generation is zero and the thermal generation requirement is maximum. Load Generation Balance (LGB) for above mentioned nine scenarios considered for the study was prepared. To prepare load generation balance, details about the selection of points on load curve and generation despatching philosophies are discussed subsequently.

All India peak demand considered for current study time-frame 2027-28 is about 294 GW. To find out variation of this demand for nine scenarios, demand pattern of year 2021-22 for the three representative months of three seasons were collected from Grid Controller of India Ltd. for monsoon (Aug-21), summer (Jun-21) and for winter (Feb-22). The data comprises of demand profile of all the days of the month with resolution of 5 mins time interval. Three load conditions each corresponding to solar max, evening peak and night off peak were selected from the representative demand curve of three seasons as depicted in

Figure 3-2, Figure 3-3 & Figure 3-4 below. For evening peak scenario and night off peak scenario, maximum demand (between 3:55 pm to 11:55 pm) and minimum demand (between midnight to 06:00 am) were considered respectively. However, for solar max scenario, maximum demand corresponding to noon (12:00 pm) was considered. To obtain the demand factors for study time-frame of 2027-28, demand corresponding to these load conditions were divided by maximum All India/regional demand of the corresponding year i.e. 2021-22. All India/regional demand factors for different scenarios of 2027-28 are shown in **Figure 3-5**.

Figure 3-2: Summer (June'21) Load Curve

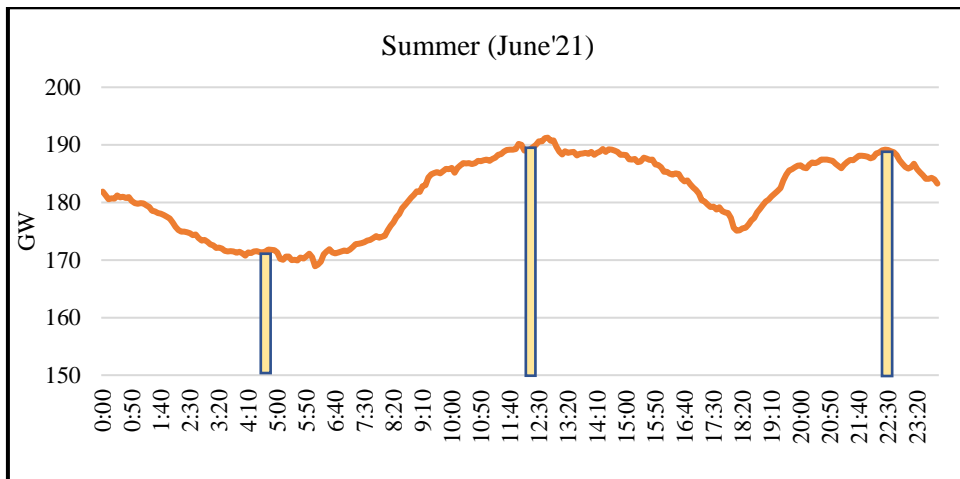

Figure 3-3: Monsoon (Aug'21) Load Curve

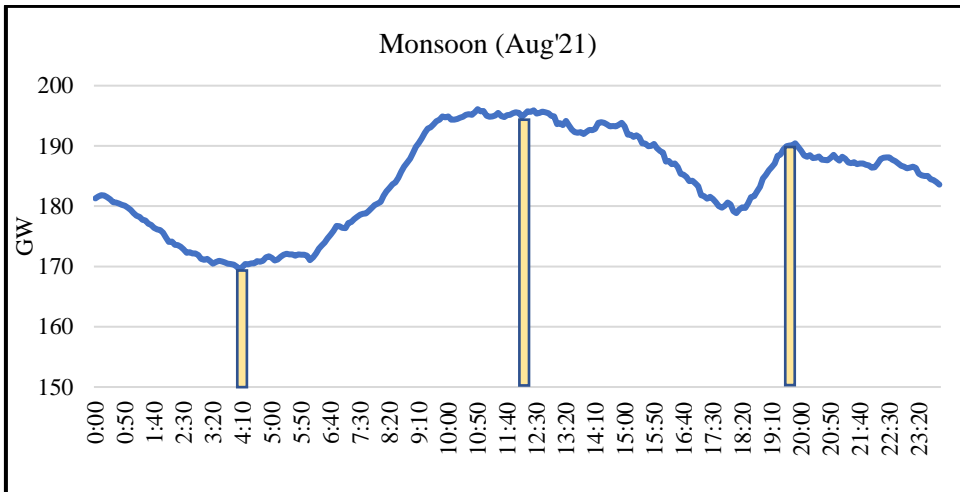

Figure 3-4: Winter (Feb'22) Load Curve

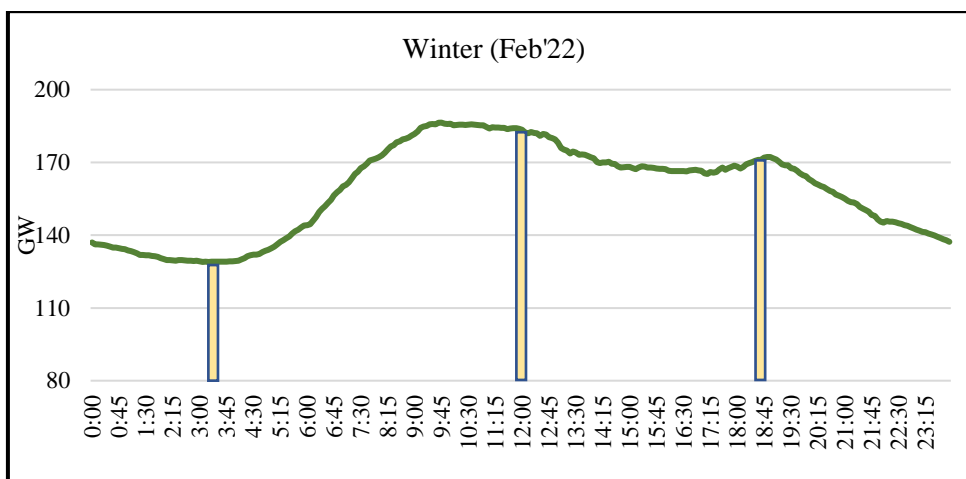
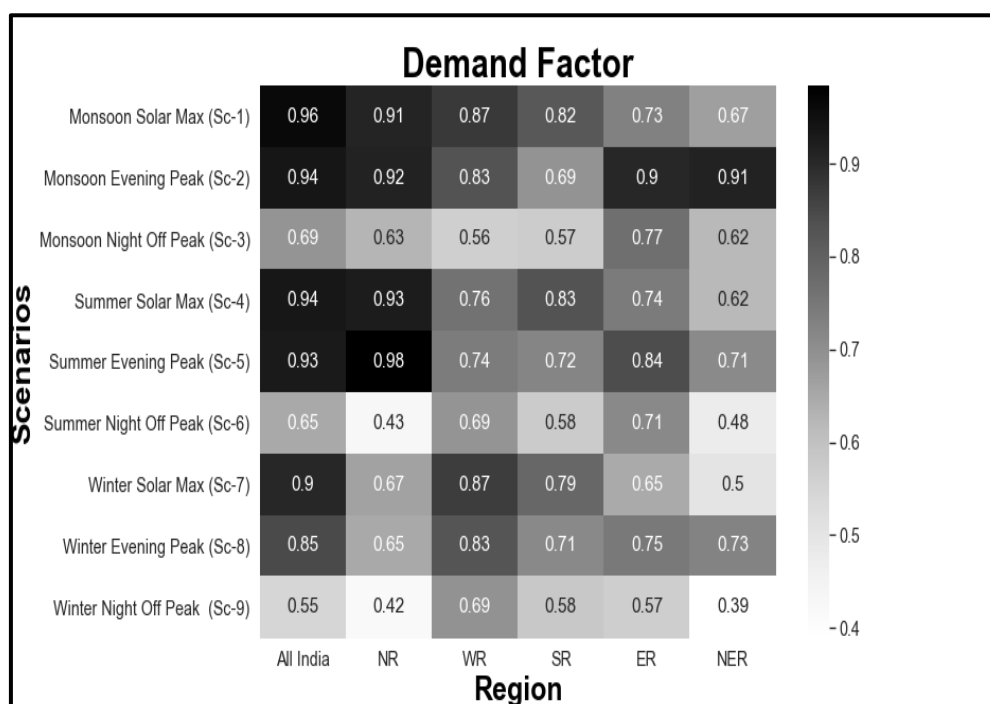

Figure 3-5: Demand factors considered for 2027-28-time frame



To meet the anticipated demand in different scenarios, various sources of generations viz. Thermal, Nuclear, Hydro, Gas, Solar, Wind are available. However, despatch of some of these generators shall be as per their diurnal and seasonal variation. Each generation except thermal generation in a region was despatched as per the despatch factors considered in regional chapters.

RE has been considered as must-run,. Since all utilities have RE RPO obligation, total RE generation has been apportioned as per RE RPO to all regions based on their projected EPS demand. Further the present demand met by solar rooftops are not monitored, it is assumed that corresponding growth in demand would also be met by rooftop. After determining the demand met by renewable energy, nuclear and hydro generation, balance demand was met by Thermal.

Evening peak scenario of each month was setup first to determine number of thermal units on bar considering the maximum dispatch. Total thermal generation requirement for the evening peak scenario was apportioned between State and Central sector thermal generations as per their installed capacity in each region. Further, state thermal generation requirement was divided among the states as per their maximum demand in respective month of 2021-22. After obtaining state thermal generation requirement, thermal units were dispatched at technical maximum (85%) in merit order for each state.

ISGS, CGS & IPP thermal plants with lower variable cost were dispatched at technical maximum (85%) region wise progressively. To meet the demand of any deficit region, thermal generation dispatches from other regions considering all India merit order for evening peak scenario was considered. For night off-peak scenario, on bar thermal units were scaled down proportionately.

While preparing the present LGB for Solar max scenario, some plants were switched off to balance the load generation while running all the on-bar thermal plants at technical minimum of 55%. Accordingly, thermal plants with higher cost (on merit order basis) were switched off region wise progressively till the LGB is balanced.

It is observed that in the Solar max scenario there is surplus power available in the grid. It is due to availability of peak solar generation and lesser demand in the noon. This surplus is on account of keeping the same number of thermal plants operating at technical minimum (55%) in Solar max scenario which are required to meet evening peak demand. Even after considering the flexibility exhibited by gas and hydro generation between the evening peak and Solar max scenario the surplus generation in terms of GW dispatches along with storage of 29 GW is given in **Figure 3-6** below.

Figure 3-6: Generation surplus in GW with Tech Min (55%) for Thermal Units

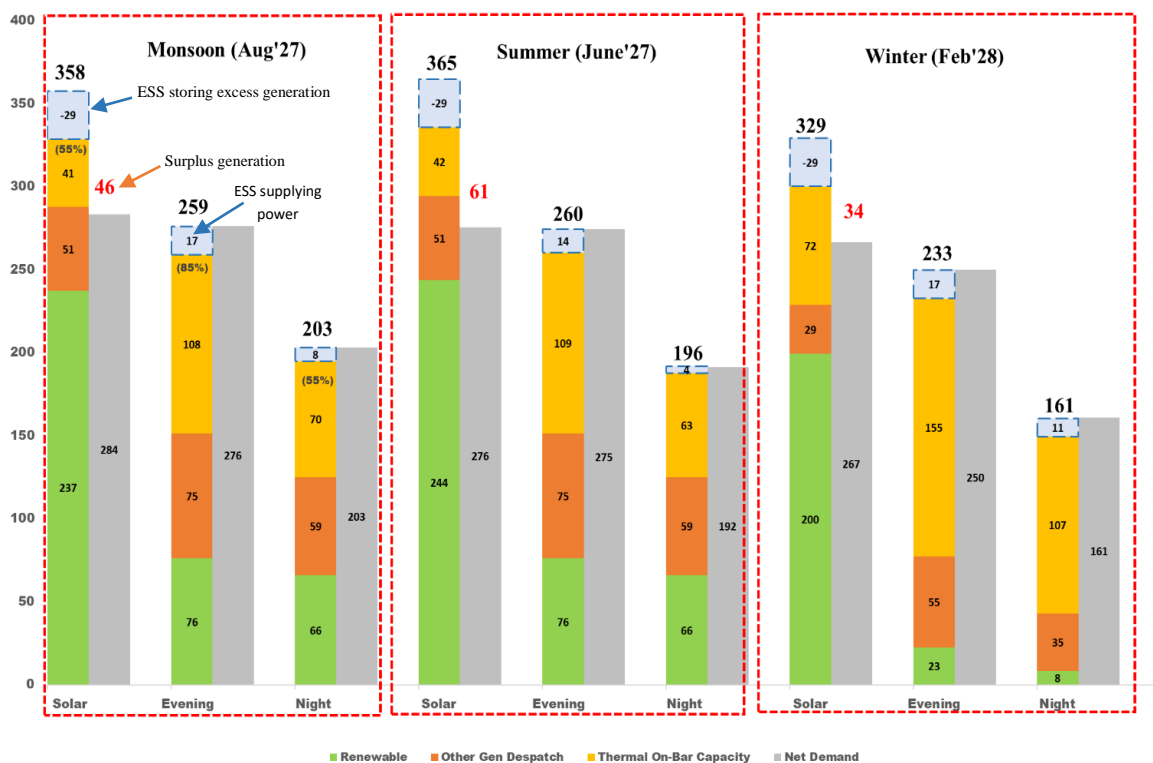

It may be observed that surplus generation of 74 GW, 61 GW, and 63 GW is available during Solar max in Monsoon, Summer, and Winter season respectively if we don't consider any storage system. However, if we consider energy storage system of 29 GW, surplus generation reduces to 46 GW, 61 GW, and 34 GW during Solar max in Monsoon, Summer and Winter season respectively as shown in Figure 3-6 . Therefore, it is recommended to store a part of the surplus generation using energy storage and consumed in other hours of the same day.

A sensitivity analysis is done to check the quantum of surplus generation, if thermal units are backed down to 40% of their capacity and the corresponding results are given in Figure 3-7 below:

Figure 3-7: Generation surplus in GW with Tech Min (40%) for Thermal Units

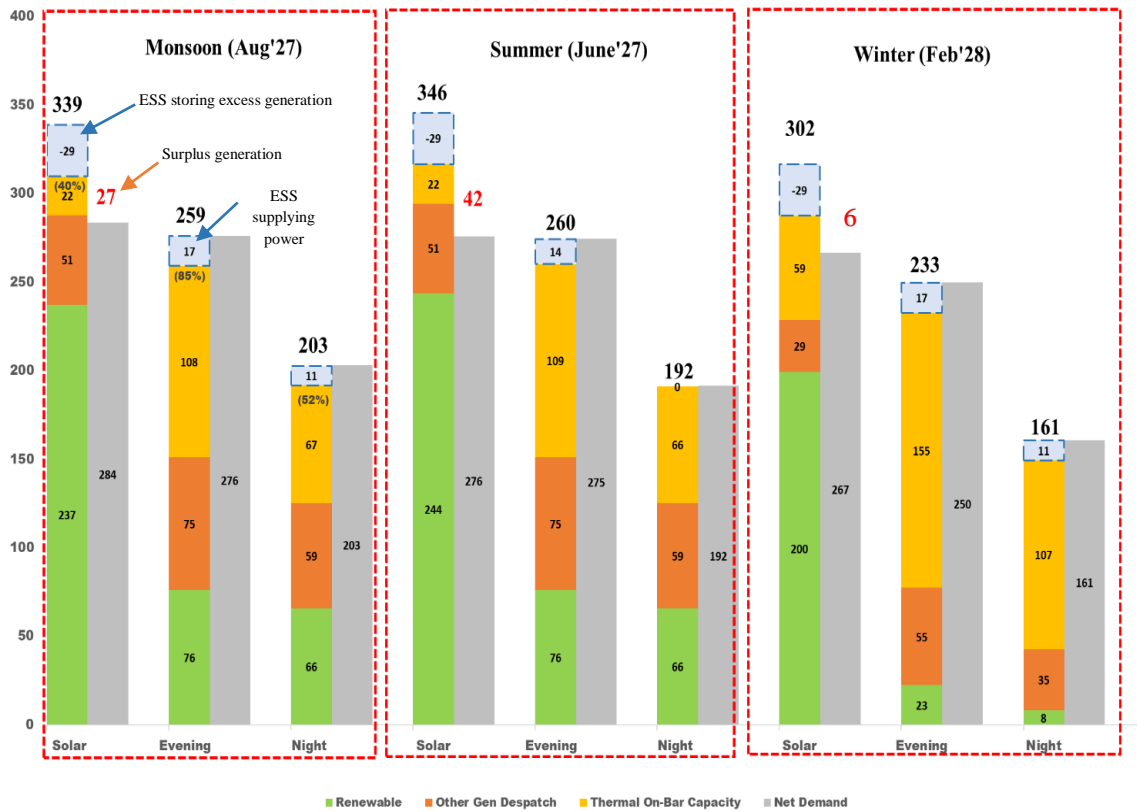

Even after backing down thermal units to 40%, surplus generation of the order of 55 GW, 70 GW, and 35 GW during Solar max in Monsoon, Summer, and Winter season respectively if we don't consider any storage system. However, if we consider energy storage system of 29 GW, surplus generation reduces to 27 GW, 42 GW, and 6 GW during Solar max in Monsoon, Summer, and Winter season respectively as shown in Figure 3-7. To absorb the maximum RE generation during the day time most of the thermal units are required to shut down necessitating the requirement of two-shift operation of thermal generation.

Based on above philosophy, LGB prepared for different scenarios are depicted in Figure 3-8, Figure 3-9, Figure 3-10 along with regional surplus/deficit scenario and details about the same are attached at **Annex-2.1**

Out of these nine scenarios, Scenario-1(Aug'27 Solar max) and Scenario-9 (Feb'28 Night off peak) corresponds to two extreme cases with respect to demand i.e., highest demand (314 GW including the ESS charging demand) and lowest demand (161 GW) scenarios respectively. In all other scenarios, all India demand is varying between these two demands as per demand factors. Further Scenario-4 corresponds to maximum RE generation share to meet the demand of that scenario. Based on LGB, region wise surplus/deficit in each scenario is summarised in Table 3-1. It may be noted here that cross-border transactions are also considered as a part of Eastern Region and BESS charging is included over and above the EPS demand in Solar Max scenarios. Furthermore, both maximum surplus and deficit of each region is highlighted in **Table 3-1**.

Monsoon Aug'2027

Figure 3-8: LGB for Monsoon Aug'2027

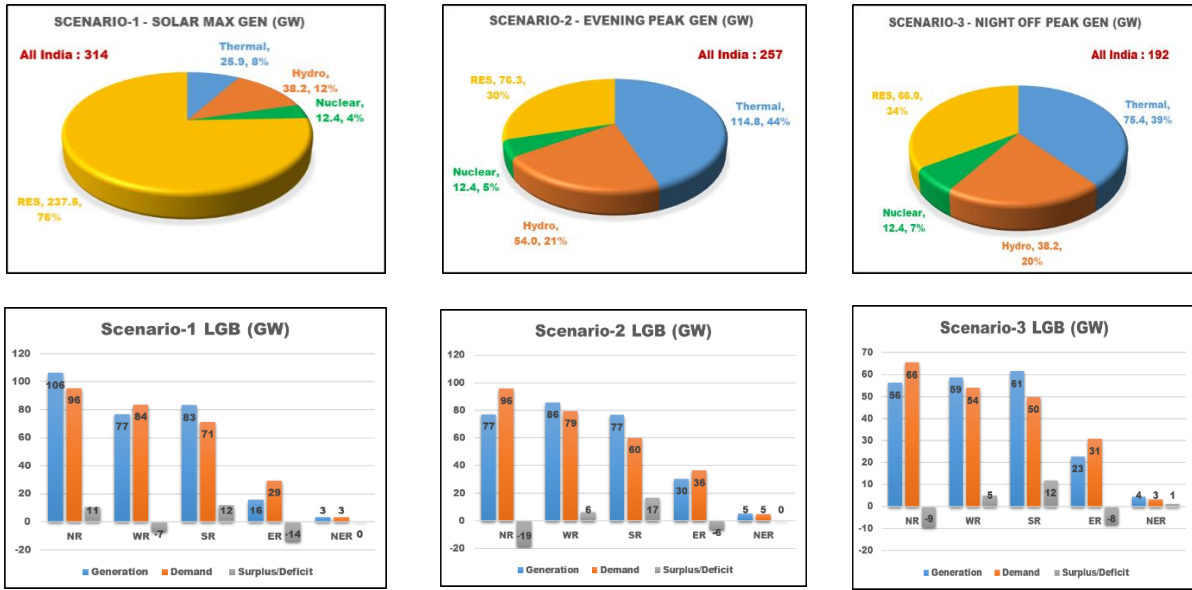

Summer June'2027

Figure 3-9: LGB for Summer June'2027

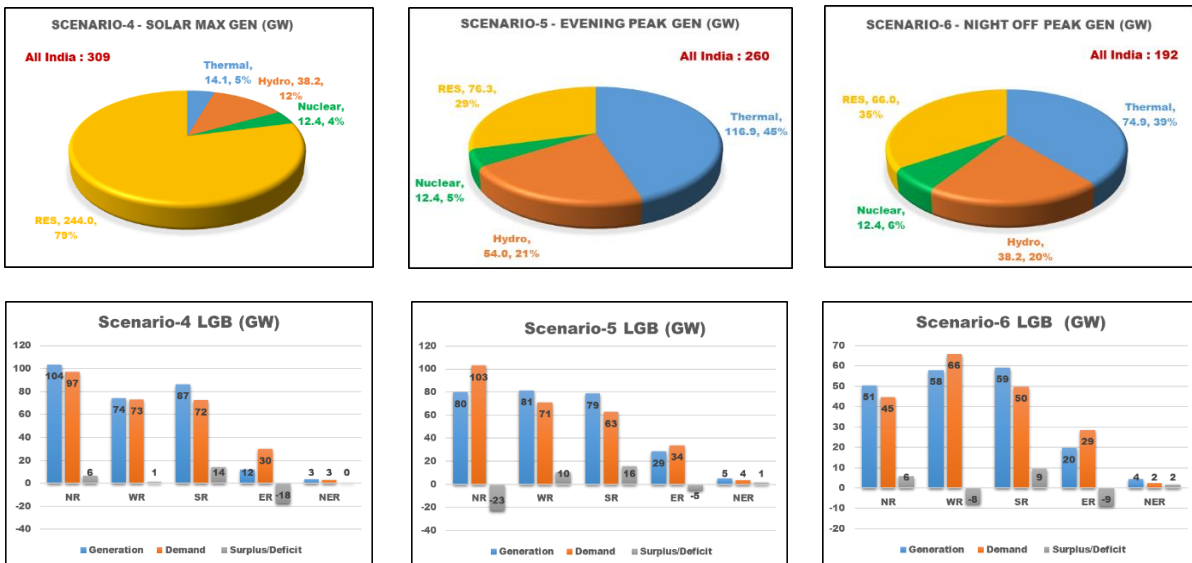

Winter Feb'2028

Figure 3-10: LGB for Winter Feb'2028

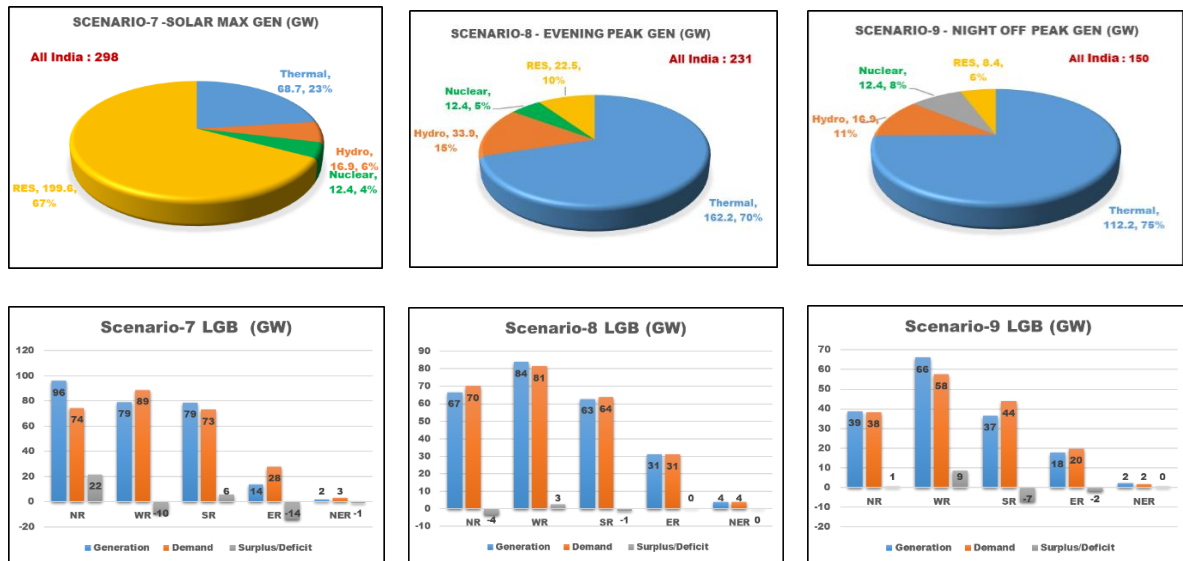

Table 3-1: Regional Surplus/Deficit summary

(All Fig in MW)

Surplus (+) / Deficit (-)	Monsoon (Aug'27)			Summer (Jun'27)			Winter (Feb'28)		
	1	2	3	4	5	6	7	8	9
	Solar Max	Evening Peak Load	Off Peak	Solar Max	Evening Peak Load	Off Peak	Solar Max	Evening Peak Load	Off Peak
NR	10762	-18627	-9278	6394	-23039	5803	21644	-3550	577
WR	-7072	6090	4784	1365	10407	-7921	-9640	2525	8540
SR	11879	16500	11730	14096	15827	9362	5521	-1017	-7300
ER	-13844	-6176	-8102	-17683	-5408	-8818	-14068	235	-1926
NER	-45	403	1066	203	1457	1820	-1096	-40	414

From the above table it may be inferred that:

- NR is importing power in evening peak scenario whereas, it is exporting power in solar max scenario due to high solar generation in NR. Maximum import of power of about 23 GW is expected in Summer (June) evening peak load scenario & maximum export of about 21 GW power is expected in Winter (Feb) solar max scenario.
- WR generally anticipated to exports the power with a maximum export of 10 GW in Summer (Jun) evening peak scenario. Due to low availability of RE during Winter (Feb) solar max scenario, WR is envisaged to become deficit to the tune of 9 GW.
- SR is projected to export power or become self-sufficient in monsoon & summer scenarios. Only in winter scenario it is expected to import power. Maximum export of power is about

16 GW in Monsoon (Aug) evening peak scenario, whereas maximum import of the order of 7 GW is projected in the Winter (February) night off peak scenario.

- ER is likely to import power in all scenarios due to RE RPO requirements which it shall not be able to meet from its own regional RE. Only in case of winter evening peak scenario ER is likely to meet its own power requirement due to maximum generation from thermal resources.
- NER mostly exports power in different scenarios except for Winter (February) it is importing power due to low hydro generations.

Considering the above LGB for nine scenarios, load flow cases were prepared for detailed studies to assess the adequacy of Inter State Transmission System including inter-regional corridors planned to cater the power transfer requirement across the region in study timeframe of FY 2027-28. Study results of the same have been discussed in subsequent sections.

3.2 Study Results and Analysis

Based on the above load-generation scenarios, various simulation studies have been carried out in PSSE. Transmission system planned and under implementation for various loads/generations scheduled to be commissioned for current study timeframe of 2027-28 are considered. Based on the studies performed, results are analysed and deliberated below-

3.2.1 Power Flow Analysis

a) Inter-Regional Corridor

Inter-regional flows between various regions within India, based on simulation studies for current study timeframe of 2027-28 are summarised below in Table 3-2 for all the nine scenarios. Maximum and minimum flow between each inter-regional corridor are also highlighted in **Table 3-2**.

Table 3-2: IR flow summary

(All Fig in MW)

IR Flows Scenario No.	Monsoon (Aug'27)			Summer (Jun'27)			Winter (Feb'28)		
	1 Solar Max	2 Peak Load	3 Off Peak	4 Solar Max	5 Peak Load	6 Off Peak	7 Solar Max	8 Peak Load	9 Off Peak
WR-NR	-3740	15543	10062	2282	19972	-2874	-12357	1398	825
ER-NR	-7567	861	-2301	-8557	1376	-4697	-10195	428	-1929
ER-WR	-9643	-6221	-6607	-11858	-6990	-5460	-10085	-1791	-3228
ER-SR	1233	139	-93	-692	552	837	1247	1794	2469
WR-SR	-13572	-15937	-11765	-13191	-16610	-10287	-6837	27	4854
ER-NER	3	-121	-706	-414	-1166	-1263	1103	351	37

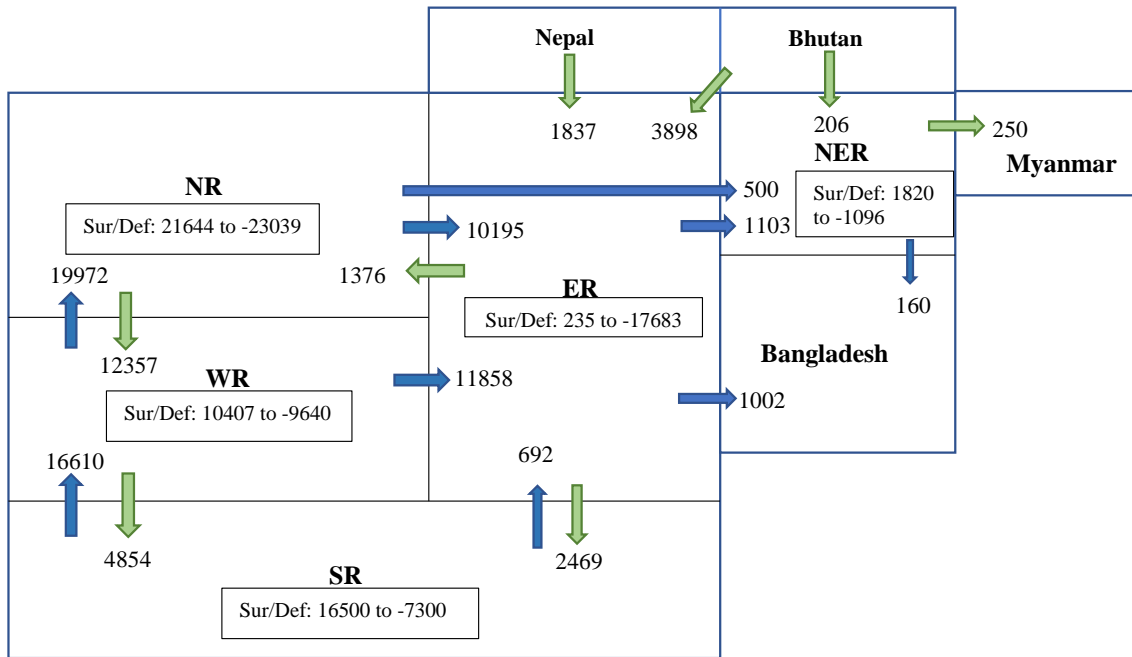

From the above it can be seen that-

- Power on WR-NR corridor is flowing in both directions in different scenarios. Maximum power of the order of 20 GW is flowing from WR to NR in June evening peak scenario whereas, maximum power flow of the order of 12 GW is flowing from NR to WR in February solar max scenario.
- Power on ER-NR corridor is flowing in both directions in different scenarios. Maximum power of the order of 10 GW is flowing from NR to ER in winter solar max scenario whereas maximum power flow of the order of 1.3 GW is flowing from ER to NR in summer evening peak scenario.
- Power on ER-WR corridor is always flowing in the directions of WR to ER with maximum flow of 11 GW in Summer solar max scenario.
- Power on ER-SR corridor is flowing in both directions in different scenarios. Maximum power from SR to ER is 0.7 GW and power from ER to SR is 2.4 GW.
- Power on WR-SR corridor is mostly flowing towards WR from SR with maximum flow of 16 GW. However, about 5GW power flows from WR to SR in winter night off peak.

Each inter-regional corridor comprises of multiple 765 kV, 400 kV, 220 kV & HVDC transmission lines. Loading on these inter-regional tie lines for all nine scenarios along with their permissible thermal design limit are tabulated in **Annex-2.2** and power flow exceeding 70% of thermal design limit are highlighted in yellow in the same annexure.

b) Transmission Line

All the 765 kV and 400 kV lines of ISTS and Intra-state were monitored for any possible overloading in the base case prepared for nine scenarios. There are about 388 nos. of 765 kV lines and about 2354 nos. of 400 kV lines. Lines with their base case loading were compared with their thermal design limit and flows exceeding the 70% of thermal design limit in any of the scenario are tabulated at **Annex-2.3**. In terms of percentage, less than 1% of total no. of lines (both 765 kV and 400 kV) are loaded beyond 70% of thermal limit. Summary of the results is shown below in **Figure 3-11 & Figure 3-12**:

Figure 3-11: 765kV Tr. line flow > 70% of thermal limit under base case

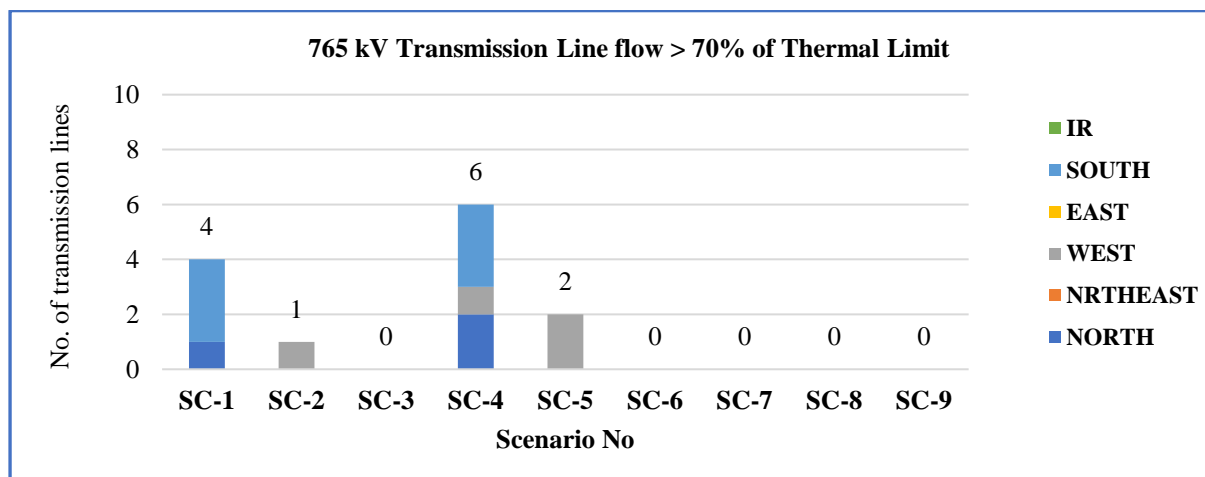
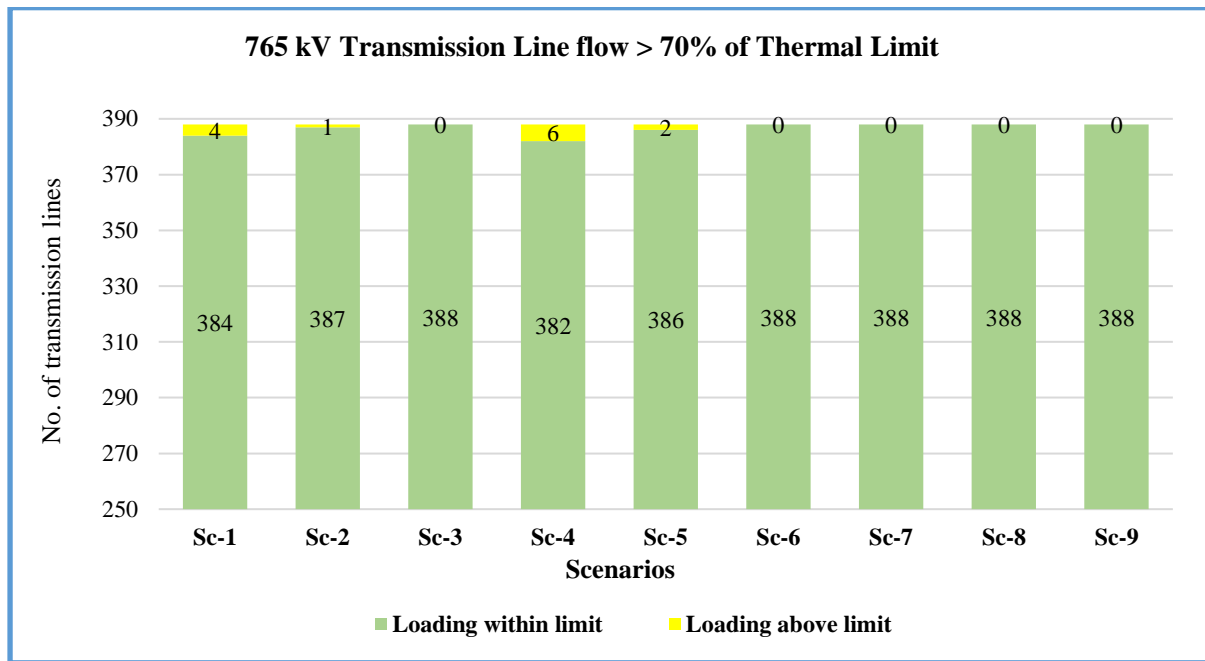
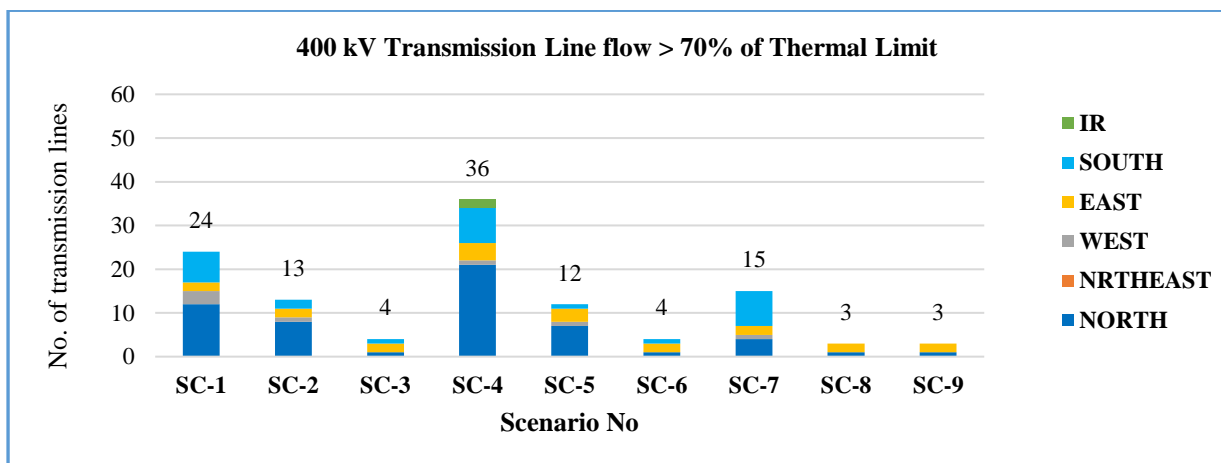
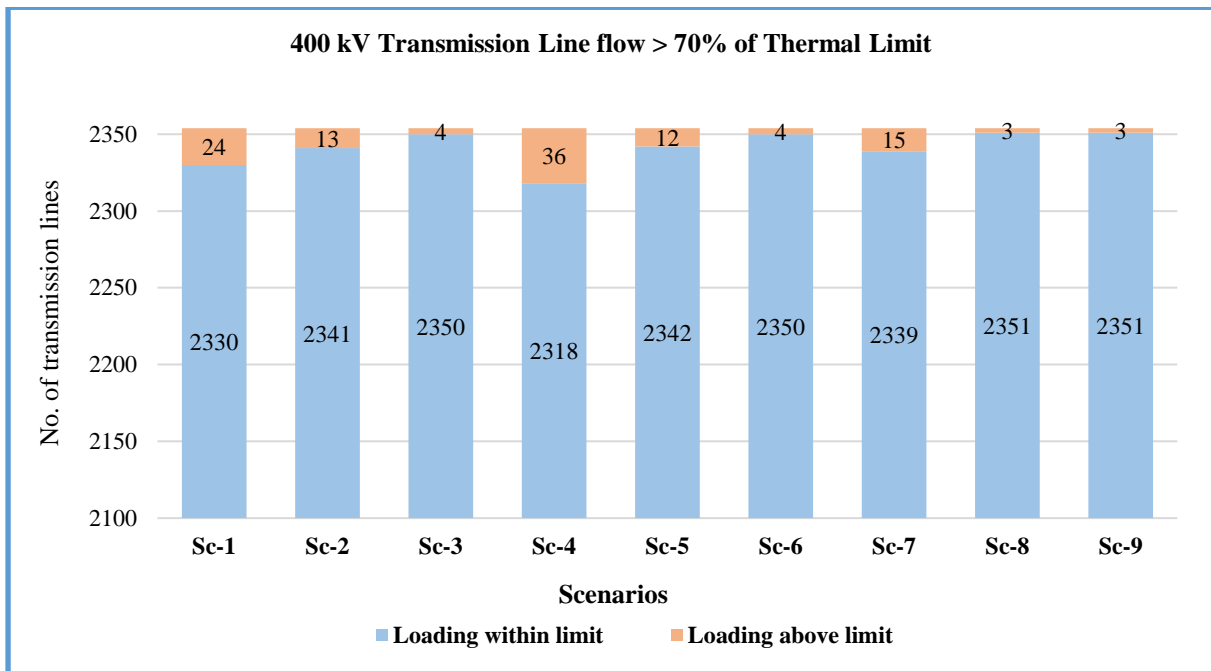

Figure 3-12: 400kV Tr. line flow > 70% of thermal limit under base case



It was observed that about 4 and 6 nos. of 765 kV lines in Scenario-1 and 4 respectively are loaded beyond 70% of the thermal limit. About 24, 36 and 15 nos. of 400 kV lines in Scenarios- 1, 4, and 7 (Solar max scenarios) respectively are loaded above 70% of the thermal limit. However, to analyse the criticality of this loading, detailed contingency studies have been carried out, which are discussed in subsequent sections.

c) Transformer

In the study time frame, there would be about 373 nos. of 765/400 kV transformer at 139 nos. of 765/400 kV substations. Loading patterns of these transformers obtained from simulation studies are tabulated in **Annex-2.4** and loading more than 80% of their rating in any scenarios are also highlighted. Number of substations, where loading is more than 80% of rating in all scenarios are depicted in **Figure 3-13** & **Figure 3-14**. However, in terms of percentage, less than 8% of transformers of 765/400 kV substations are loaded beyond 80% of their rating.

Figure 3-13: 765/400kV ICT Loading under base case

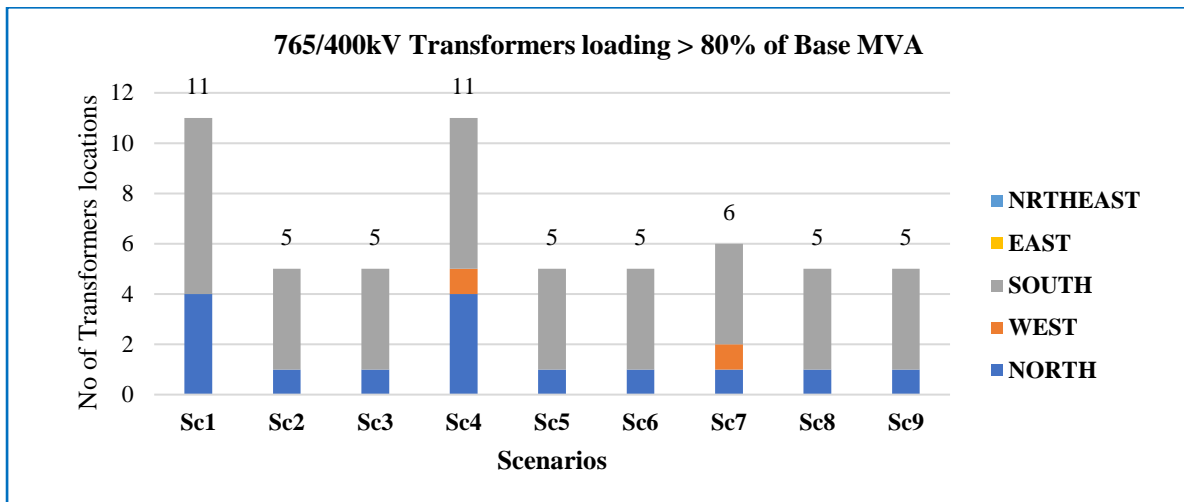

Under solar max scenarios viz. Scenarios 1, 4 and 7 about 18, 20 and 14 substations located in different region, where ICTs are getting loaded above 80% of MVA rating. Maximum number of substation where loading is above 80% of MVA rating are corresponding to solar max scenarios. These substations are located in northern, western and southern region due to non-availability of transformers under N-1 contingency at RE pooling stations.

Similar analysis was carried out for 400/220 kV transformers. There are 1477 nos. of transformers located at about 557 nos. of 400/220 kV stations.

Figure 3-14: 400/220kV ICT loading under Base Case

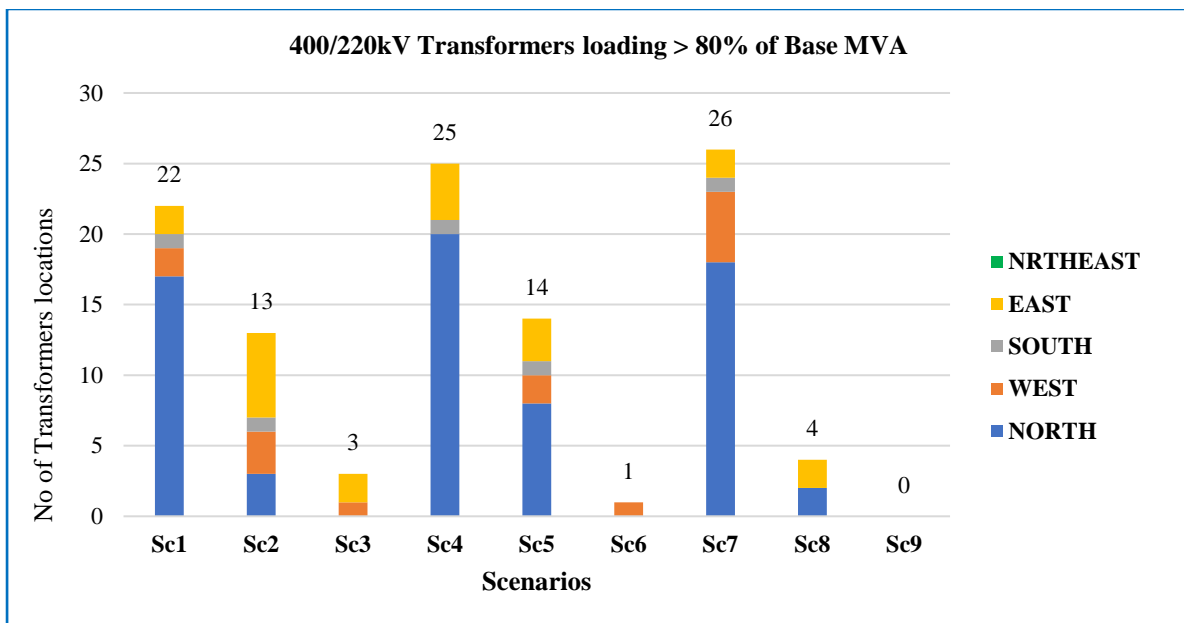

Under solar max scenarios viz. Scenarios 1, 4 and 7 about 56, 64 and 46 substations located in different region, where ICTs are getting loaded above 80% of MVA rating. However, if we see in terms of percentage, less than 4% of transformers of 400/220 kV substations are loaded beyond 80% of their rating. The need for augmentation would depend upon the number of

transformers, parallel paths availability etc. Hence simulation with contingencies is discussed in subsequent sections.

d) Voltage Profile

With injection of high amount of RE into the Indian Grid, it is expected that in the same day power flow on a line would reverse. Transmission lines associated with thermal and hydro would be lightly loaded in solar max scenarios. Though adequate reactive compensation is planned in the form of switchable line reactors, bus reactors, STATCOMs, SVCs at the time of inception of transmission projects. Impact of various shunt devices on voltages of all buses in all the scenarios are observed and analysed.

PU voltages of all 765 kV and 400 kV buses were observed in all the nine scenarios. Maximum and minimum voltage of each bus was identified from nine voltages available in nine scenarios. For voltage variation beyond ± 0.05 pu from nominal voltage was considered as voltage violation. Maximum and minimum voltage of buses is considered to calculate the number of buses having voltage beyond 1 pu and voltage below 1 pu respectively. Results of the analysis is plotted below in **Figure 3-15**.

Figure 3-15: Voltage Profile of 765 KV & 400 KV buses

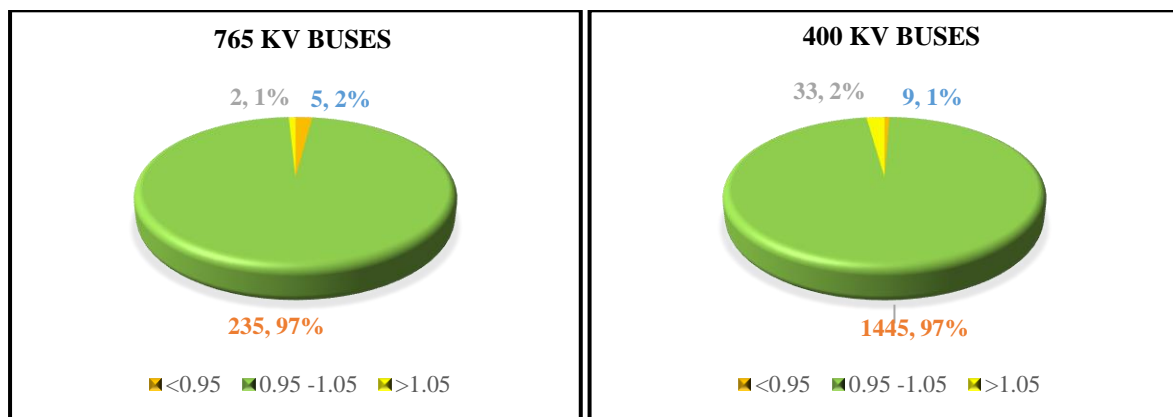

From the above voltage plots it can be seen that around 97% of the buses at 765 kV level and at 400 kV level voltage are found to be in the range of 0.95 to 1.05 pu in All India Base case scenarios. There are around 33 Nodes at 400 kV voltage and 2 nodes at 765 kV in any one of the scenarios are having voltage beyond 1.05 pu. Similarly, around 5 nodes at 765 kV and 9 nodes at 400 kV are facing low voltage in one of the scenarios.

Details of the buses exceeding the voltage 1.05 pu and buses having voltage below the 0.95 pu in any of the scenario are enclosed at **Annex-2.5**. For buses experiencing low voltages, measures like switching of switchable line reactors, increasing operating voltage of nearby generators may be taken.

3.2.2 Contingency Analysis

Contingency analysis has been carried out on all the 765 kV & 400kV transmission lines, and 765/400 kV & 400/220 kV transformers to ascertain the loading levels under outage of any other 765 kV or 400 kV transmission element. Results of the analysis are discussed below:

a) Transmission Line

765kV line loadings beyond 3000 MW under N-1 was assessed first. Thereafter, to carry out a sensitivity analysis, number of lines loaded beyond 3200 MW and 3500 MW under N-1 contingency were also identified. The list of such lines is at **Annex-2.6** and the same has been summarised below in **Figure 3-16, Figure 3-17 & Figure 3-18.**

Figure 3-16: 765kV Tr. line loadings >3000MW under N-1 Contingency

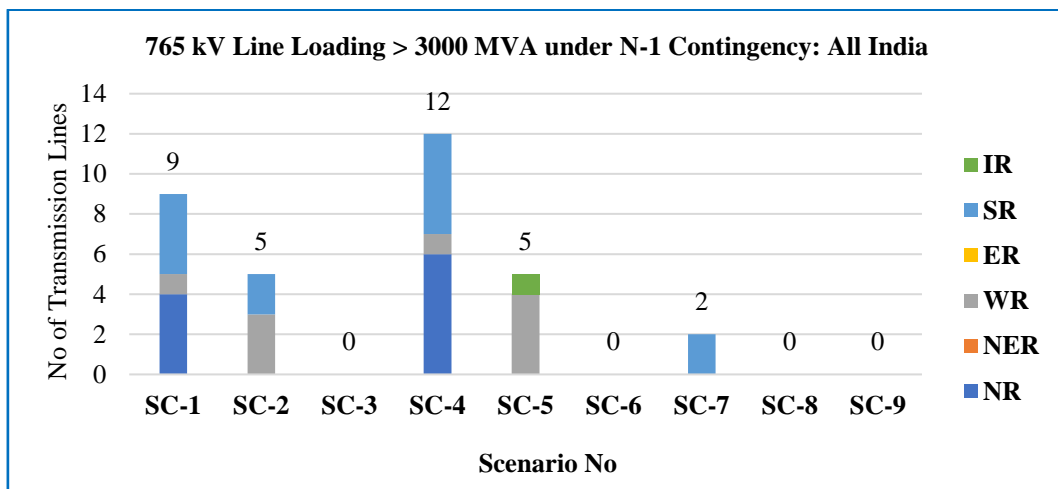

Figure 3-17: 765kV line loading >3200 MW under N-1 Contingency

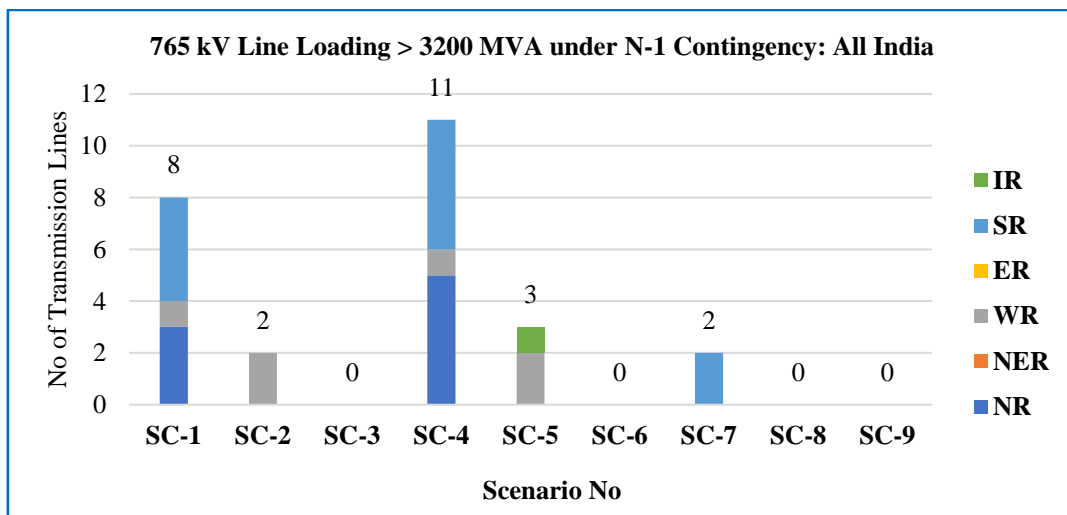
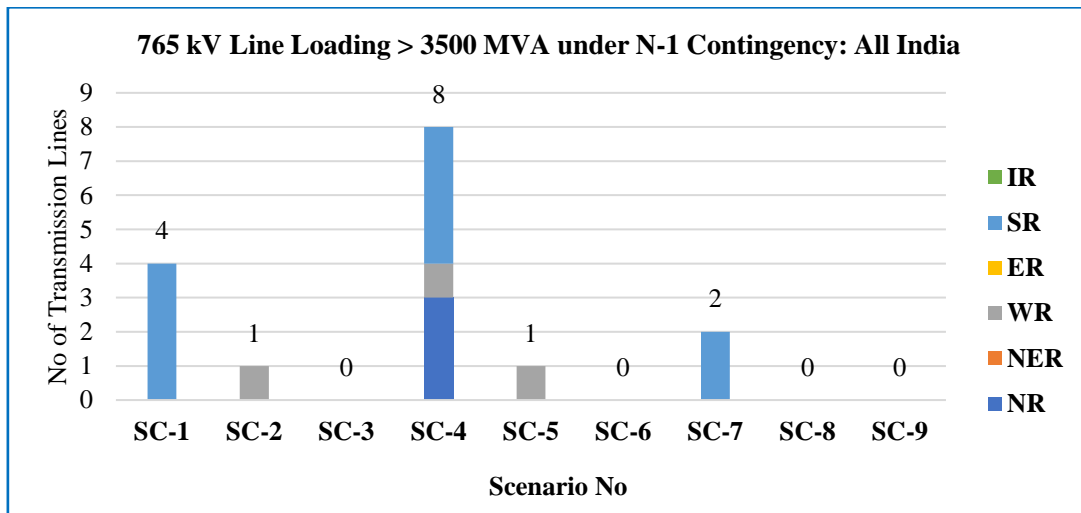

Figure 3-18: 765kV line loading > 3500 MW under N-1 Contingency



The most critical 765 kV lines are Nizamabad-Nizamabad-2, Cudappah – Cudappah-2, Kurnool-Maheshwaram, Greater Noida-Aligarh. Maximum loadings occur during solar max scenarios. Detailed studies regarding the reason for the overloading and probable mitigation measures are discussed in respective regional chapters.

Further, for 400kV transmission lines, loading greater than 90% and 100% of thermal limit under N-1 Contingency has been assessed and the results are tabulated at **Annex-2.6**. The results are summarised below in **Figure 3-19** & **Figure 3-20**.

Figure 3-19: 400kV line loading > 90% of thermal limit under N-1 Contingency

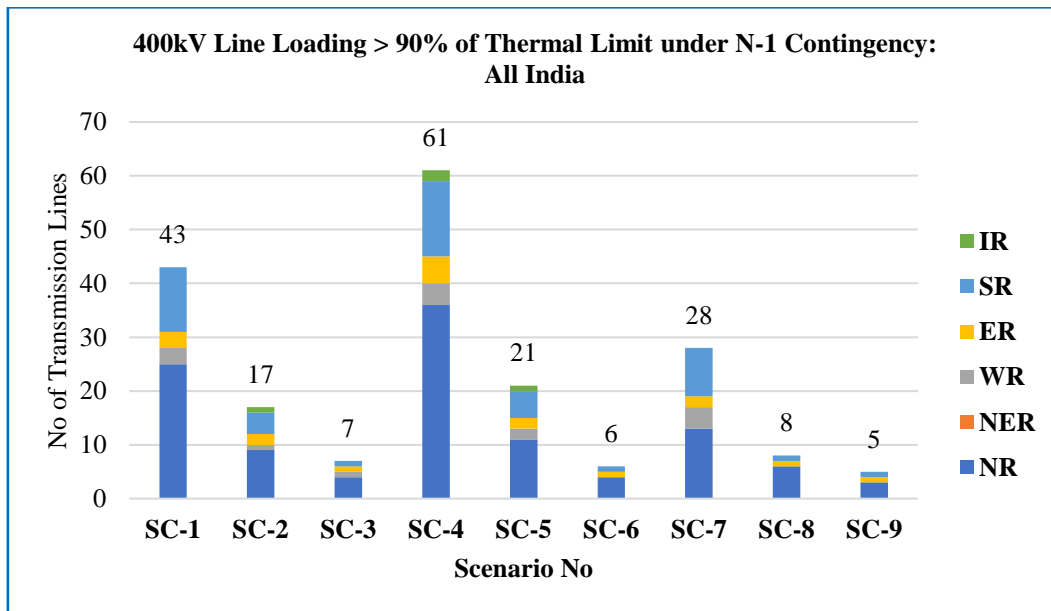
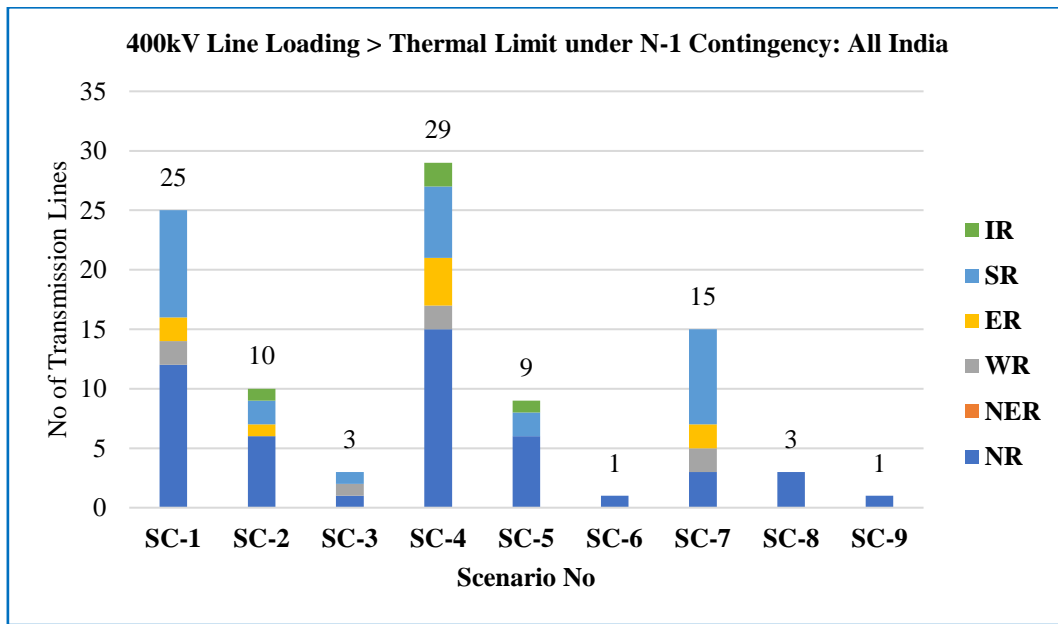

Figure 3-20: 400kV line loading > thermal limit under N-1 Contingency



Max no. of 400kV lines on which loadings exceeds 90% and 100% of thermal limit are 61 and 29 respectively in Solar max scenarios i.e. Scenario-4. Further, detailed analysis and studies are being carried to plan additional systems, if any.

b) Transformers

Number of substations where ICTs shall get loaded above 90% and 100% of MVA rating under N-1 contingency are depicted below in Figure 3-21 & Figure 3-22 for 765/400 kV ICT and **Figure 3-23 & Figure 3-24** for 400/220 kV ICT . Detailed results are attached at **Annex-2.7**.

Figure 3-21: 765/400kV ICT loading ≥ 90% of MVA rating under N-1 Contingency

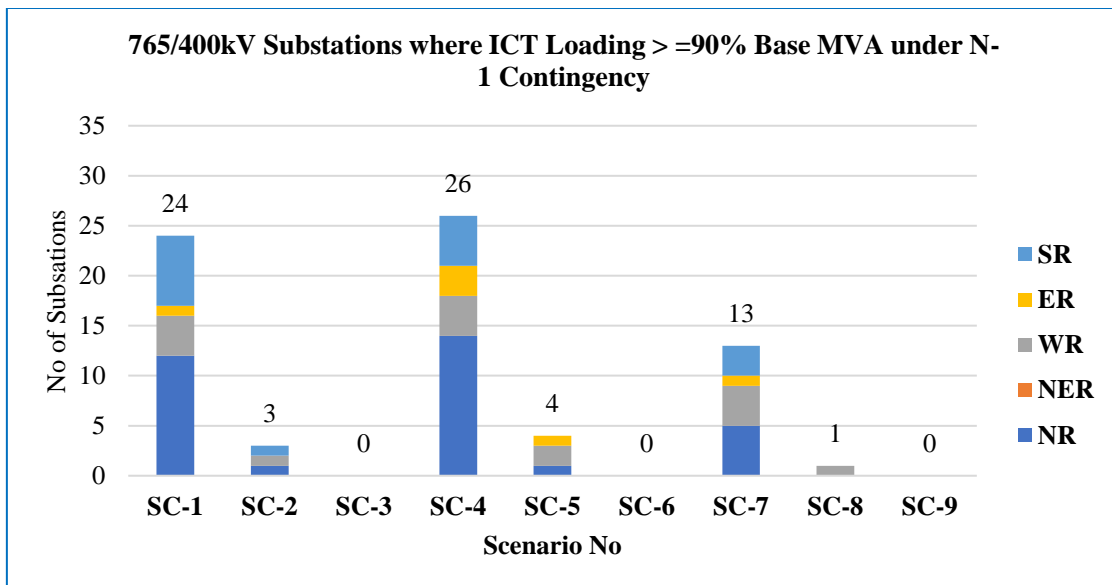
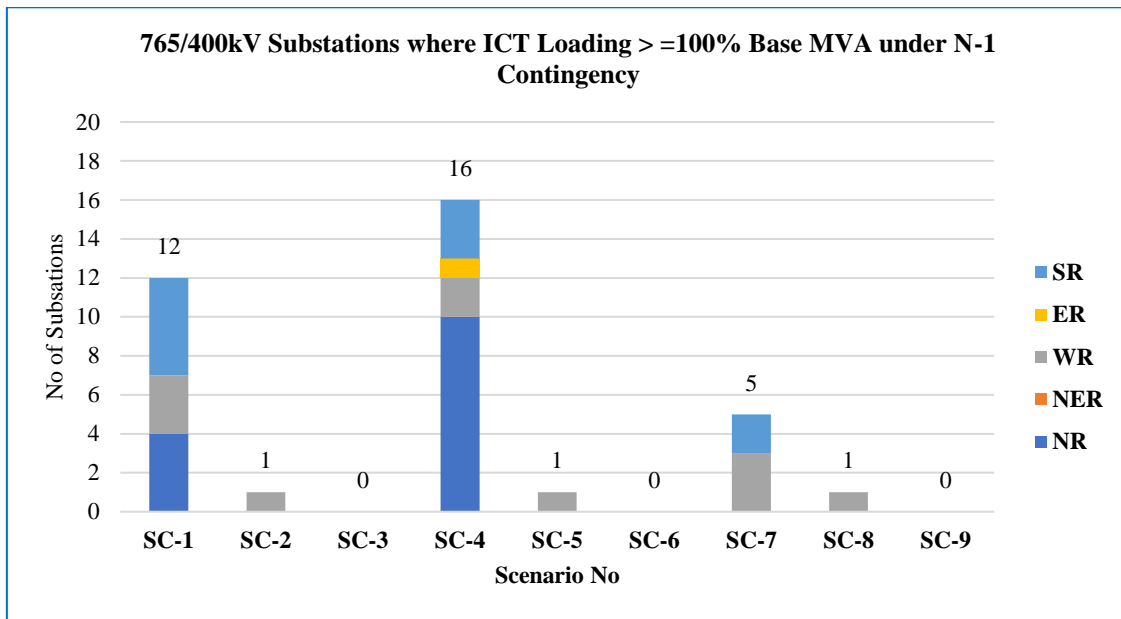

Figure 3-22: 765/400kV ICT loading $\geq 100\%$ of MVA rating under N-1 Contingency



Maximum number of transformers exceeding the loading greater than MVA rating under N-1 contingency in each of the seasons are corresponding to Solar max scenarios viz. Scenarios-1, 4 and 7. Some of the locations corresponding to Scenario-1,4 and 7 where ICT loading violations have been observed are BhiwaniSR, BhiwaniPG, Bhadla-3, Bhadla-2, Jhatikala, Kurnool, Warangal, Sipat, Jhasurguda, Bareilly, Dausa, Maheshwaram, Varanasi & Aurang. Few of these substations are RE pooling stations where ICTs have been planned considering N-0, as per Manual on Transmission Planning Criteria 2013. Thus, detailed studies are being carried out to plan for remedial measures.

Figure 3-23: 400/220kV ICT loadings $\geq 90\%$ of MVA rating under N-1 Contingency

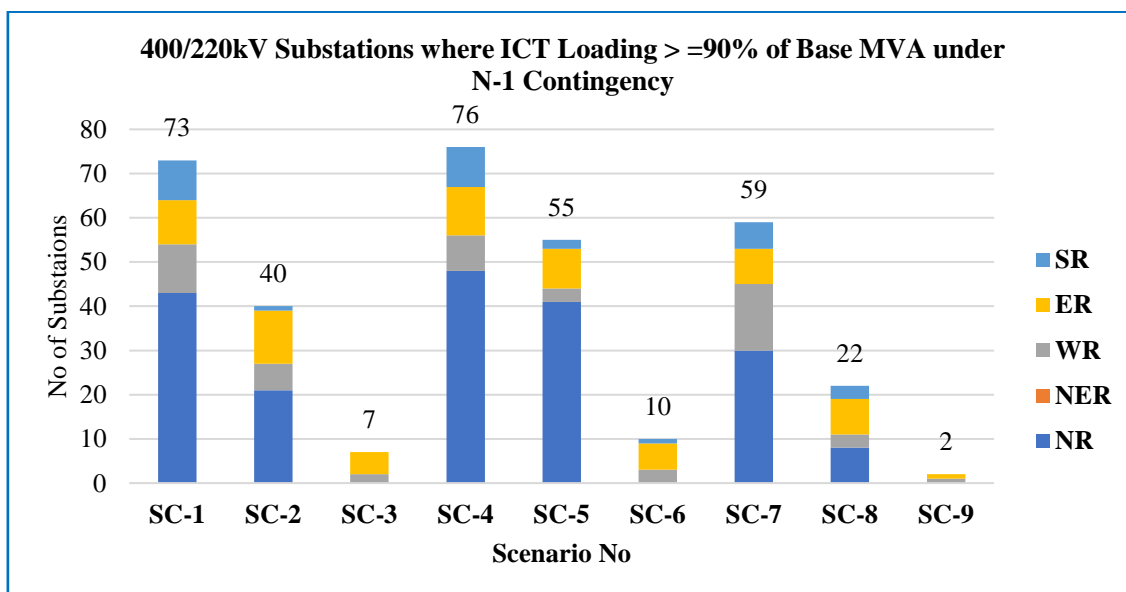
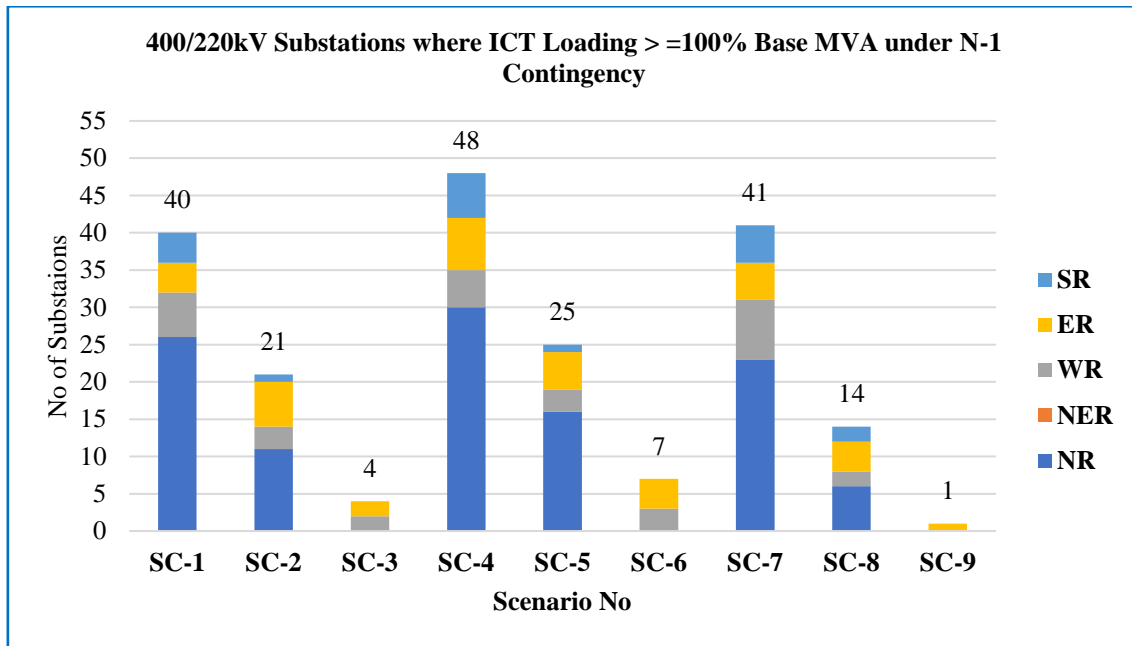

Figure 3-24: 400/220kV ICT loadings $\geq 100\%$ of MVA rating under N-1 Contingency



Maximum number of transformers exceeding the loading greater than MVA rating under N-1 contingency in each of the seasons are corresponding to Solar max scenarios viz. Scenarios-1, 4 and 7. Majority of these substations are RE pooling stations where ICTs have been planned considering N-0, as per Manual on Transmission Planning Criteria, 2013. Thus, about 40 no. of substations requires ICT augmentation, which are being studied in detail in respective regional chapters.

3.2.3 Short Circuit Analysis

Short circuit level was calculated for all 765 and 400 kV buses on pan India basis. For conducting the short circuit studies, sub transient reactance (X_d'') has been used for all thermal and hydro machines. Fault contribution from solar PV plants is limited to 1 p.u. as per various inverter capabilities during the studies After finding the fault level for all buses exceeding the design fault level under any scenario were identified. It was observed that no such violations were found in 765 kV buses. Figure 3-25 shows the number of 765 kV and 400 kV buses exceeding the design fault current under different scenarios. About 9 no. of 765 kV busses were observed to be crossing the design fault current limit in Scenario-8 & 9. In 400 kV buses about 33 and 35 no. of busses were observed to be crossing the design fault current limit in Scenario-8 & 9 respectively. Details about the buses exceeding design fault current limit are attached at **Annex-2.8** under various scenarios.

Figure 3-25: Short circuit level 765 kV and 400 kV buses on pan India basis

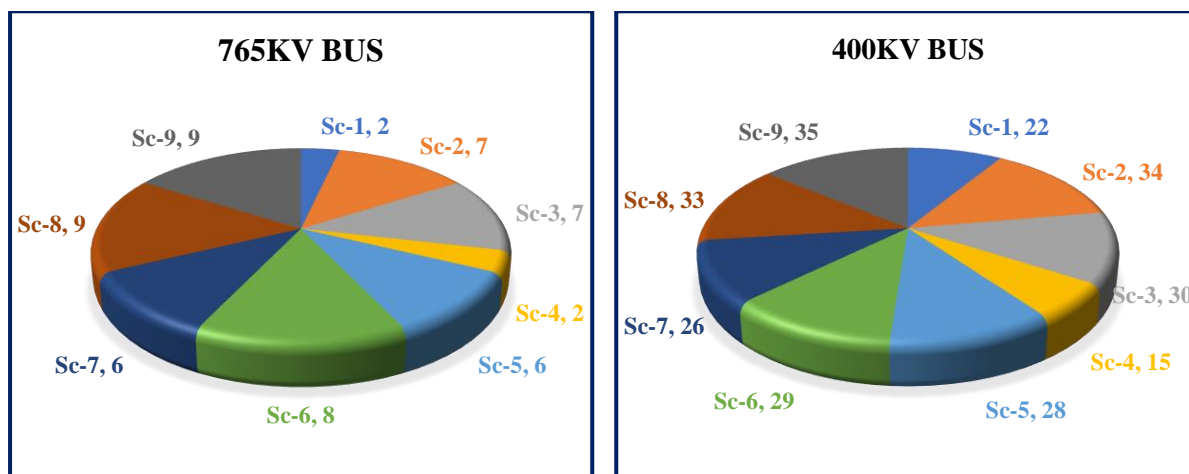

From the above charts, it can be seen that number of fault level violations are highest in February scenario i.e. scenario - 8 and 9. It is noticed that number of thermal machines on bar are maximum in February scenario. Hence fault contribution from these machines shall be maximum under these scenarios. In **Figure 3-26**, the number of violation taking place at ISTS/STU/Gen buses in any of the scenarios are identified and same is represented below.

Figure 3-26: Violation of fault level at ISTS/STU/Gen buses at 765 kV and 400 kV levels

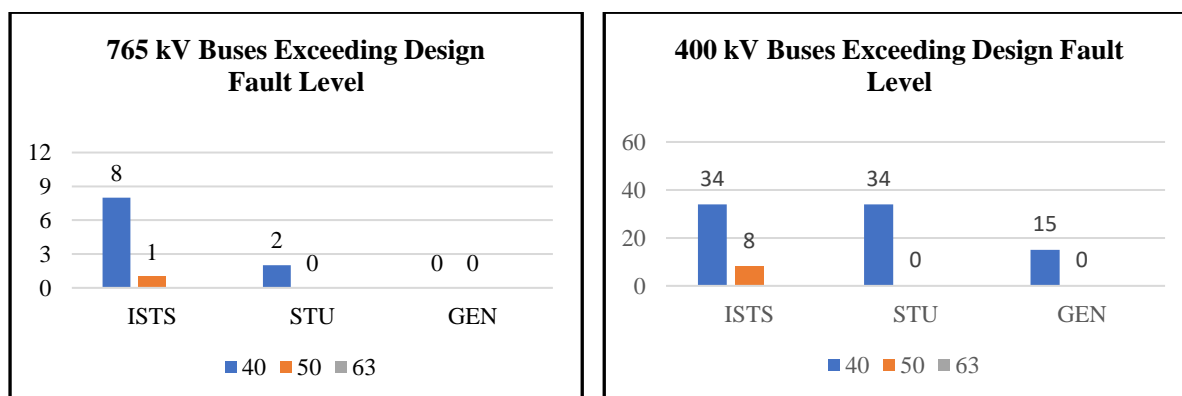

Further to understand the criticality of the case, maximum fault violation at buses are tabulated below in **Table 3-3**

Table 3-3: Maximum violation of fault level at ISTS/STU/GEN buses

<ul style="list-style-type: none"> ➤ 765 kV ISTS <ul style="list-style-type: none"> ▪ Jabalpur-Pool(50kA): 53kA ▪ Kurl (40kA): 52kA 	<ul style="list-style-type: none"> ➤ 400 kV ISTS <ul style="list-style-type: none"> ▪ Merrut(40kA): 67kA ▪ Bikaner-nw(40kA): 57kA
<ul style="list-style-type: none"> ➤ 765 kV STU <ul style="list-style-type: none"> ▪ Jaipur(40kA): 45kA ▪ GNOIDAU(40kA): 44kA 	<ul style="list-style-type: none"> ➤ 400 kV STU <ul style="list-style-type: none"> ▪ GNOIDAUP (40kA): 60KA ▪ Agra (40kA): 58kA

3.3 ISTS Expansion upto 2027-28

3.3.1 Summary of ISTS network

Region wise and year wise ISTS network expansion across the country upto FY 2027-28 is enclosed in **Annex-2.9**. Summary of ckm addition, MVA addition and the broad estimated cost of ISTS network *under construction* are tabulated below in **Table 3-4**, **Table 3-5** & **Table 3-6** respectively.

Table 3-4: Under Construction Transmission lines (in ckm)

Sl. No.	FY	WR	SR	NR	ER	NER	Total
1	2022-23	-	-	172	-	809	981
2	2023-24	2,642	1,909	3,807	80	450	8,888
3	2024-25	2,186	911	405	235	-	3,737
4	2025-26	187	-	-	-	230	417
5	2026-27	-	-	-	-	-	-
6	2027-28	-	-	-	-	-	-
	Total	5,015	2,820	4,384	315	1,489	14,023

Table 3-5: Under Construction Transformation Capacity (in MVA)

Sl. No.	FY	WR	SR	NR	ER	NER	Total
1	2022-23	1,500	-	4,820	500	200	7,020
2	2023-24	22,500	13,500	18,815	-	320	55,135
3	2024-25	30,500	8,500	-	1,050	-	40,050
4	2025-26	-	-	-	-	1,720	1,720
5	2026-27	-	-	-	-	-	-
6	2027-28	-	-	-	-	-	-
	Total	54,500	22,000	23,635	1,550	2,240	1,03,925

Table 3-6: Broad estimated cost (in ₹ Cr.) (Under Construction)

Sl. No.	FY	WR	SR	NR	ER	NER	Total
1	2022-23	-	0	1,090	54	1,601	2,746
2	2023-24	7,365	6,659	10,770	285	417	25,495
3	2024-25	11,320	3,391	1,077	594	77	16,459
4	2025-26	614	-	-	-	430	1,044
5	2026-27	-	-	-	-	-	-
6	2027-28	-	-	-	-	-	-
	Total	₹ 19,298	₹ 10,050	₹ 12,937	₹ 933	₹ 2,526	₹ 45,744

Summary of ckm addition, MVA addition and the broad estimated cost of ISTS network *under planning/bidding/approval* are tabulated below in **Table 3-7**, **Table 3-8** & **Table 3-9** respectively.

Table 3-7: Under planning/bidding/approval Transmission lines (in ckm)

Sl. No.	FY	WR	SR	NR	ER	NER	Total
1	2023-24	-	-	-	-	-	-
2	2024-25	400	700	5,410	-	-	6,510
3	2025-26	5,570	2,410	3,380	400	-	11,760
4	2026-27	2,120	2,240	3,534	-	-	7,894
5	2027-28	-	-	2,028	-	-	2,028
	Total	8,090	5,350	14,352	400	0	28,192

Table 3-8: Under planning/bidding/approval Transformation Capacity (in MVA)

Sl. No.	FY	WR	SR	NR	ER	NER	Total
1	2023-24	-	-	1,000	-	-	1,000
2	2024-25	6,000	11,000	41,435	-	-	58,435
3	2025-26	53,500	43,500	45,160	3,000	-	1,45,160
4	2026-27	18,000	44,500	12,275	-	-	74,775
5	2027-28	-	-	6,630	-	-	6,630
	Total	77,500	99,000	1,06,500	3,000	-	2,86,000

Table 3-9: Broad estimated cost (in ₹ Cr.) (under planning/bidding/approval)

Sl. No.	FY	WR	SR	NR	ER	NER	Total
1	2023-24	10	-	175	-	-	185
2	2024-25	884	2,867	15,886	-	-	19,637
3	2025-26	34,104	12,609	28,142	2,986	-	77,842
4	2026-27	23,334	11,042	19,487	-	-	53,863
5	2027-28	-	-	26,967	-	-	26,967
	Total	58,332	26,518	90,657	2,986	-	1,78,493

3.3.2 Inter-Regional (IR) Capacity

The progressive growth in Inter-Regional (IR) transmission capacity from 2011-12 till 2027-28 is given below in Figure 3-27. As on 2021-22 IR transmission capacity is 112 GW which is expected to increase to 138 GW by 2027-28.

Figure 3-27: Growth in IR Capacity

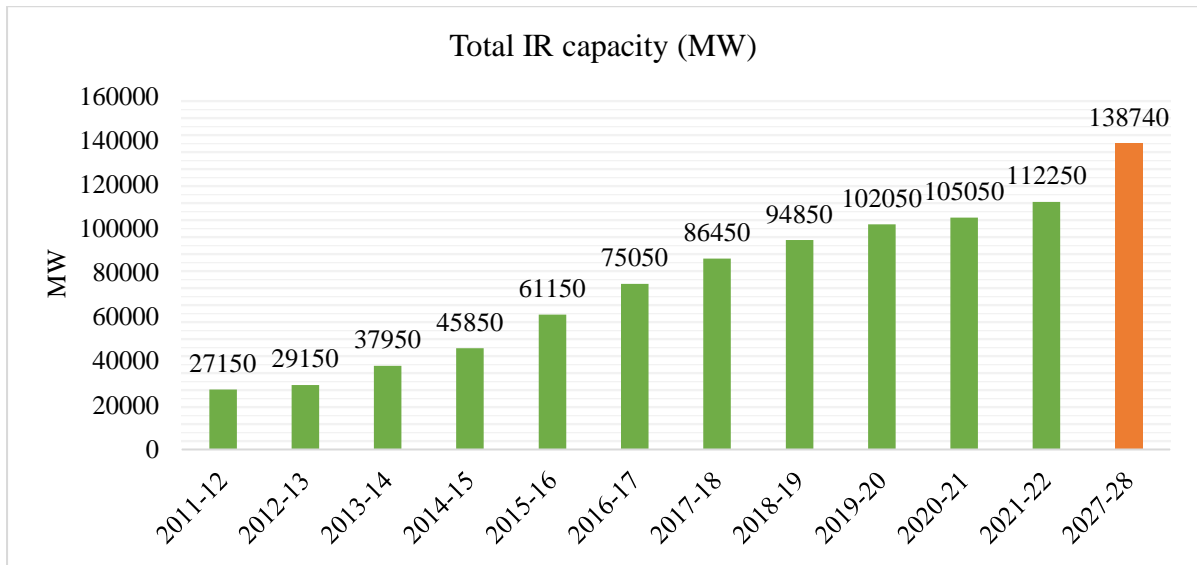

Details of approved Inter Regional corridor capacity are attached at **Annex-2.10** by 2027-28 and the schematic of the same is given below in Figure 3-28.

Figure 3-28: Inter-Regional Transmission Capacity by 2027-28

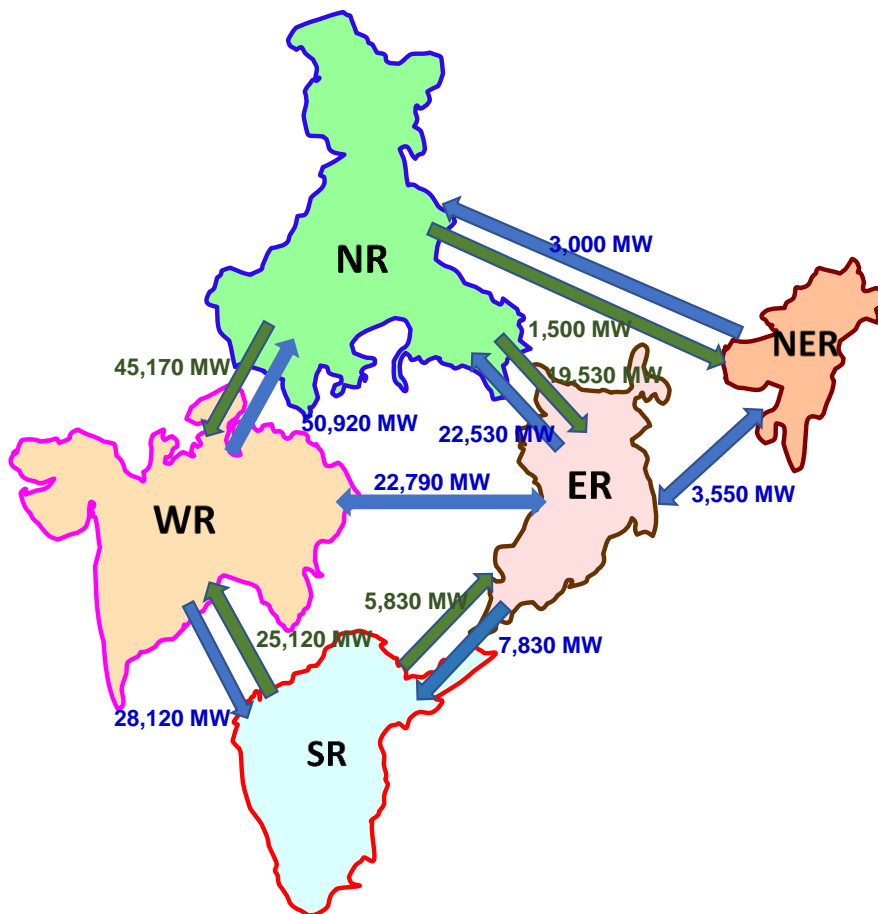

Page intentionally left blank

Chapter 4: Northern Region

Northern Region is connected to Western and Eastern Region through 765kV/400kV high capacity corridors along with Back to Back/ HVDCs. The thermal generating stations of Northern Regions are predominantly located in UP, Rajasthan and Haryana whereas hydro generation concentrated into J&K, HP and Uttarakhand. Further, Rajasthan is being a RE rich state comprise of lot of Solar & Wind capacity.

As of now Northern Region imports power from other regions during evening peak load period whereas it will export power to other regions during high RE scenarios in future.

4.1 Power Supply Scenario as on Feb'23

As on Feb'2023, total Installed Capacity of Northern Region is about 116.9 GW and the peak demand is about 77.3 GW. The state-wise breakup of installed capacity and peak demand is summarised at Table 4-1 below.

Table 4-1: Installed Capacity and Peak Demand of NR as on Feb'23

(All Fig in GW)

State	Generation							Grand Total	Peak Demand
	Fossil			Non Fossil					
	Thermal	Gas	Total	Nuclear	Hydro	RES	Total		
Chandigarh	0.1	-	0.1	-	0.1	0.1	0.2	0.2	0.4
Delhi	3.6	2.1	5.8	0.1	0.7	0.3	1.1	6.9	7.7
Haryana	8.6	0.6	9.2	0.1	2.3	1.4	3.8	13.0	12.8
Himachal Pradesh	0.1	-	0.1	-	3.2	1.1	4.3	4.5	2.1
Jammu & Kashmir and Ladakh	0.6	0.3	0.9	0.1	2.3	0.2	2.6	3.5	3.1
Punjab	8.2	0.2	8.4	0.2	3.8	1.8	5.9	14.2	14.3
Rajasthan	13.3	0.8	14.1	0.6	1.9	21.2	23.7	37.8	17.4
UP	20.4	1.0	21.4	0.3	3.4	4.8	8.5	29.9	27.4
Uttarakhand	0.5	0.5	1.0	-	2.1	0.9	3.1	4.1	2.6
Central unallocated	1.4	0.3	1.7	0.2	0.8	-	1.0	2.7	-
NR	56.9	5.8	62.7	1.6	20.8	31.8	54.2	116.9	77.3

Source: CEA monthly report

From above, it can be concluded that share of non-fossil fuel based generation capacity in total present installed capacity (IC) of 116.9 GW is 54.2 GW i.e 46% of total IC. This share would further increase in envisaged scenario of 2027-28 timeframe.

4.2 Envisaged Power Supply Scenario by 2027-28

As per the 20th EPS, Northern Region demand for 2027-28 timeframe is expected to increase to about 103.7 GW. As per the inputs received from various stakeholders, total installed

capacity of Northern Region for 2027-28 is expected to be about 200 GW. The state wise bifurcation of installed capacity and peak demand is summarized below at **Table 4-2**.

Table 4-2: Northern Region Installed Capacity and peak demand (2027-28)

(All Fig in GW)

State	Generation									Peak Demand
	Fossil			Non Fossil				ESS	Grand Total	
	Thermal	Gas	Total	Nuclear	Hydro	RES	Total			
Delhi	0.5	1.5	2.0	-	-	-	-	-	2.0	9.9
Haryana	3.6	-	3.6	-	0.1	0.9	1.0	-	4.6	17.4
Himachal Pradesh	-	-	-	-	0.3	-	0.3	-	0.3	2.7
Jammu & Kashmir	-	0.2	0.2	-	1.2	-	1.2	-	1.4	3.9
Punjab	5.7	0.0	5.7	-	1.4	-	1.4	-	7.0	17.7
Rajasthan	10.0	0.2	10.2	-	0.5	20.7	21.3	-	31.5	22.4
UP	22.0	-	22.0	-	1.3	4.2	5.5	-	27.5	35.1
Uttarakhand	-	-	-	-	2.2	-	2.2	-	2.2	3.4
Chandigarh	-	-	-	-	-	-	-	-	-	0.5
Central	11.9	1.8	13.6	4.4	14.2	73.9	92.5	7.5	113.7	-
IPP	-	-	-	-	4.1	-	4.1	-	4.1	-
Rooftop / Other RE	-	-	-	-	-	5.9	5.9	-	5.9	-
NR	53.7	3.6	57.3	4.4	25.3	105.6	135.3	7.5	200.1	103.7

From above, it is observed that growth in installed capacity of Northern Region is majorly from non-fossil fuel based generation resources. Share of non-fossil fuel based generation capacity in total present installed capacity (IC) is expected to be increased from 46% to 68%. There is a growth in peak demand of Northern Region from present time-frame (2022-23) to 2027-28 with a CAGR of 6%. The state wise peak demand growth is given at Table 4-3.

Table 4-3: Increase in Peak Demand of Various States of NR

(All Fig in MW)

	Peak Demand			
	2022-23	2027-28 (20 th EPS)	Increase in demand	CAGR (%)
Chandigarh	407	505	98	4.41
Delhi	7695	9948	2253	5.27
Haryana	12768	17380	4612	6.36
Himachal Pradesh	2071	2699	628	5.44
Jammu & Kashmir & Ladakh	3137	3863*	726	4.25
Punjab	14311	17684	3373	4.32
Rajasthan	17399	22358	4959	5.14
UP	27369	35082	7713	5.09
Uttarakhand	2594	3433	839	5.76
NR	77337	103650	26313	6.03

*incl. 91MW of Ladakh

From the above data it is observed that the CAGR growth of peak demand is maximum for Haryana (6.3%) and minimum for J&K (4.2%).

4.3 Load Generation Balance for 2027-28 Timeframe

In Chapter-3, All India Load Generation Balance (LGB) for identified nine scenarios - was prepared as per the methodology finalized in consultation with CTU, CEA and GRID INDIA. This section elaborates the Northern Region Load Generation Balance (LGB) for 2027-28 time-frame. For Northern Region also, three points on the daily load curve i.e. Solar max (afternoon), Peak load (evening) and Off-peak load (night) for three seasons viz. Monsoon (August), Summer (June) and Winter (February) have been considered.

Load generation balance has been prepared considering the generation despatch factors as mentioned at Table 4-4 for the 9 scenarios. Further, thermal generators have been despatched as per the merit order.

Table 4-4: Northern Region Generation Dispatch and Demand Factors

Scenario No & Name	Hydro	Nuclear	Solar	Wind	ESS	Gas	Regional DF
1-Aug Solar Max	70%	80%	90%	50%	-100%	0%	92%
2-Aug Peak Load	95%	80%	0%	70%	60%	50%	92%
3-Aug Night Off Peak	70%	80%	0%	60%	40%	50%	63%
4-Jun Solar Max	70%	80%	90%	50%	-100%	0%	94%
5-Jun Peak Load	95%	80%	0%	70%	50%	50%	99%
6-Jun Night Off Peak	70%	80%	0%	60%	1%	50%	43%
7-Feb Solar Max	30%	80%	90%	10%	-100%	0%	72%
8-Feb Peak Load	60%	80%	0%	35%	60%	50%	68%
9-Feb Night Off Peak	30%	80%	0%	10%	40%	30%	37%

The despatch from thermal generations have been done considering merit order despatch. Based on the LGB, import / export of NR and the inter regional flows through various corridors is summarised in subsequent sections. Further, both maximum and minimum is also highlighted in table below.

Table 4-5: IR Flows & Surplus/Deficit (Northern Region)

(All Fig in MW)

IR Flows	Aug'27 (Monsoon)			Jun'27 (Summer)			Feb'28 (Winter)		
	1	2	3	4	5	6	7	8	9
Scenario No.	Solar Max	Peak Load	Off Peak	Solar Max	Peak Load	Off Peak	Solar Max	Peak Load	Off Peak
WR-NR	-3740	15543	10062	2282	19972	-2874	-12357	1398	825
ER-NR	-7567	861	-2301	-8557	1376	-4697	-10195	428	-1929
NER-NR	-500	0	0	-500	0	0	-500	0	0
NEPAL-NR	1435	1837	1438	1431	1837	1442	618	1236	618
NR	10372	-18241	-9199	5775	-23185	6129	22434	-3062	486

Considering the above LGB for nine scenarios, load flow cases were prepared for 2027-28 timeframe. Detailed system studies have been carried out on the finalized load flow cases. The study results are discussed in subsequent sections.

4.4 ISTS Network Expansion Schemes Evolved from Mar'22 to Feb'23

Various transmission schemes have been discussed/finalized in the Consultative Meeting for Evolution of Transmission System of Northern Region (CMETS-NR) from March 2022 to February 2023. Brief of all such deliberated transmission schemes are tabulated below:

Sl. No.	Name of the Transmission Scheme	Expected Timeframe	Tentative Cost (in Cr.)
Inter Regional/NR Combined			
1.	WR-NR Inter-Regional (IR) : Scheme to relieve high loading of 400 kV Bhinmal -Zerda line	2024-25	279.5
2.	Reactive power compensation on 400kV transmission lines in NR.	2023-24	73.4
Rajasthan			
1.	Transmission system for evacuation of power from Rajasthan REZ Ph-IV (Part-1) (Bikaner Complex)	2025-26	13460
2.	Implementation of "N -1" contingency at RE pooling substations in NR	2024-25	101.2
3.	Transmission system for evacuation of power from Rajasthan REZ Ph-IV (Part-2 : 7.5GW) (Jaisalmer/Barmer Complex)	2025-26	13656
Himachal			
1.	Transmission system for evacuation of power from Shongtong Karcham HEP (450MW) and Tidong HEP (150 MW)	2026-27	2286
Punjab			
1.	Enhancement of ATC/TTC for Punjab due to unprecedented load growth of summer/ paddy season	2024-25	130.88

Details of the schemes are reproduced below state-wise:

4.4.1 Inter Regional/Other

a. WR-NR Inter-Regional (IR : Scheme to relieve high loading of 400 kV Bhinmal -Zerda line

The Joint Study Meeting on Transmission Planning for Northern Region & Western Region was held on 21.03.2022, 28.03.22 & 29.03.22 amongst CEA, CTU, GRID INDIA, WR, and NR constituents was held to deliberate NR-WR Inter-regional (IR) transmission system requirement to relieve overloading of Bhinmal-Zerda line under various operating conditions. In the Joint Study meeting, the following scheme was proposed by CTU as per the immediate requirement (Phase-I: short term) to relieve 400kV WR-NR IR corridor loadings:

- Bypassing of 400 kV Kankroli - Bhinmal-Zerda lines at Bhinmal to form 400 kV Kankroli – Zerda (direct) line #

- Reconductoring of 400 kV Jodhpur(Surpura)(RVPN) – Kankroli S/c line with twin HTLS conductor*-188 km

with necessary arrangement for bypassing Kankroli- Zerda line at Bhinmal with suitable switching equipment inside the Bhinmal substation

**with minimum capacity of 2100 MVA/ckt at nominal voltage; Upgradation of existing 400kV bay equipment's each at Jodhpur (Surpura)(RVPN) and Kankroli S/s (3150 A)*

After deliberations in the meeting, it was decided that Ph-1 (short term) scheme may be implemented as inter regional system strengthening scheme (ISTS) on urgent basis. The matter was also discussed and agreed in the 5th CMETS NR held on 30.03.2022. Subsequently, POWERGRID provided inputs stating that with recent experience of Re-conductoring of various old lines based on HTLS conductor design principles for 400kV lines designed with ACSR Moose conductor for 85 Deg C, ampacity of around 1400 Amperes may be possible with GAP & Composite Core type HTLS Conductor. For higher ampacity corresponding to 2100MVA capacity, GAP type HTLS Conductor may not be suitable and Composite Core type HTLS conductor may be the only option.

It was also mentioned that the Composite Core type HTLS conductors is very costly (around 3 times to that of equivalent ACSR), whereas, GAP is economical (around 1.5 times to that of equivalent ACSR). With ampacity requirement of 1400A, possibility of GAP & Composite core type HTLS conductor may facilitate larger vendor base leading to better competition & fair price discovery. In case of higher ampacity, limited vendors of Composite core conductor may lead to reduced competition

With 1400 Ampacity, 400kV line can be designed for about 1940 MVA. In the studies, it is observed from studies that line loading at 400 kV Jodhpur (Surpura)(RVPN) – Kankroli S/c (twin moose) line is about 1250 MW in Feb solar max scenario under worst case contingency. As the envisaged power flow is less than 1940MVA, therefore it is proposed that HTLS Conductor (Gap/Composite core) with 1400Amps(~1940MVA) may be utilized for reconductoring of 400kV Jodhpur (Surpura)(RVPN) – Kankroli S/c (twin moose) line

Based on above inputs, proposal was again deliberated in the 7th CMETS NR meeting held on 31.05.22. In the meeting, proposal for Reconductoring of 400 kV Jodhpur(Surpura)(RVPN) – Kankroli S/c line with twin HTLS conductor having minimum capacity of 1940MVA/ckt at nominal voltage was agreed

- Bypassing of 400 kV Kankroli - Bhinmal-Zerda line at Bhinmal to form 400 kV Kankroli – Zerda (direct) line #
- Reconductoring of 400 kV Jodhpur (Surpura)(RVPN) – Kankroli S/c (twin moose) line with twin HTLS conductor*-188 km

with necessary arrangement for bypassing Kankroli- Zerda line at Bhinmal with suitable switching equipment inside the Bhinmal substation

**with minimum capacity of 1940MVA/ckt at nominal voltage; Upgradation of existing 400kV bay equipment's each at Jodhpur (Surpura)(RVPN) and Kankroli S/s(3150 A)*

The schematic is enclosed in **Figure 4-1**

Scope of work along with tentative Cost and Implementation time-frame

S, No	Scope of the Transmission Scheme	Implementation time-frame	Total Estimated Cost (Rs. Cr)
1	<ul style="list-style-type: none"> ➤ Bypassing of 400 kV Kankroli - Bhinmal-Zerda line at Bhinmal to form 400 kV Kankroli – Zerda (direct) line # ➤ Reconductoring of 400 kV Jodhpur (Surpura)(RVPN) – Kankroli S/c (twin moose) line with twin HTLS conductor*-188 km <p># with necessary arrangement for bypassing Kankroli- Zerda line at Bhinmal with suitable switching equipment inside the Bhinmal substation</p> <p>*with minimum capacity of 1940MVA/ckt at nominal voltage; Upgradation of existing 400kV bay equipment's each at Jodhpur (Surpura)(RVPN) and Kankroli S/s(3150 A)</p>	18 months from allocation of project	279.5

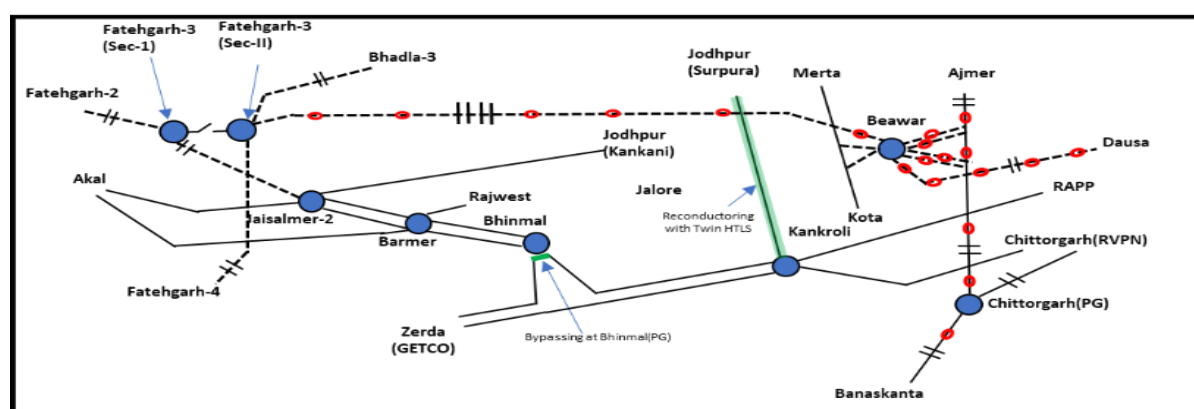

Figure 4-1: Tr. Scheme to relieve high loading of WR-NR IR Corridor

b. High voltages in the Northern Region Grid

Northern region experiences large variation in demand over various seasons and time of day. At present the demand varies from 74GW in Summer evening peak to about 28GW in winter off-peak time. Likewise, the demand in NR vary from 101GW in Summer evening peak to 44GW in Winter night off peak time in 2026-27 timeframe.

Additionally, NR has huge RE generation (mainly wind and solar) envisaged in western Rajasthan. At present NR has RE capacity of about 28GW which is envisaged to be increased to 67GW by 2026-27. Similarly, NR has 21GW of existing hydro capacity and more large scale hydro generation projects envisaged in J&K, Himachal Pradesh and Uttarakhand in next 4-5 years. As no solar generation available in evening and night time, whereas wind and hydro generation is also minimal in winter season, high voltage are observed in studies in various planning scenarios also by 2026-27-time frame.

In the 4th NRPC (TP) meeting held on 5.10.2021 and 12.10.2021, issue of high voltage and requirement of reactive compensation at the various substations in NR was discussed along with agenda of installation of line reactors as discussed in 3rd NRPC (TP) meeting. In above meeting, GRID INDIA also analyzed the issue of high voltages in Northern region and made a presentation highlighting the various nodes (44 nos.) in NR which are experiencing high voltages for which GRID INDIA proposed bus reactors at 39 nos. of nodes. After deliberations in above meeting, following was agreed :

- STUs would provide inputs regarding the reactors planned at various intra-state substations in the respective states along with their implementation timelines.
- STUs would explore the possibility of installation of reactors at the node mentioned in meeting and accordingly intimate to CEA and CTUIL
- Based on the inputs from STUs, CTUIL would carry out the studies to assess the requirement of reactive compensation at various nodes in Northern Region to overcome the issue of high voltages

As per GRID INDIA's operational feedback report of Quarter-4 (Jan'22-Mar'22), 43 nos. of substations experienced high voltage in the quarter. In the report, it is mentioned that there are 124 nos. of 400kV & above lines opened multiple times on High Voltage in last quarter in NR. Frequent switching of transmission lines to control system voltages has been observed in the NR grid during various seasonal scenarios. POWERGRID also mentioned that in Northern Region, 852 times of 400kV & above lines (91 nos. of lines) manually opened to control system voltage and 6 nos. of lines tripped on Over Voltage in Jan'22. POWERGRID informed that the frequent switching of transmission line reduces the life of transmission assets and its impact has been already highlighted to RPCs/RLDCs in various meetings.

Subsequently, issue of high voltages was deliberated in 8th Consultative Meeting for Evolving Transmission Systems in Northern Region (CMETS-NR). In the meeting it was analysed that percentage line compensation and total compensation (line+bus) in ISTS is about 61% and 105% respectively, whereas in STU system, the percentage line compensation and total compensation (line+bus) is about 39% and 89% respectively.

Further, 220 kV transmission lines of STU system as well Capacitor banks installed at downstream level also contributes significant MVARs in system especially during light load condition as However, very less compensation provided by STUs at 220kV level and below network, non-switched off Capacitor banks at downstream network adds significant reactive power flows into 400 kV network through 400/220 kV ICTs of ISTS and STU substations.

Figure 4-2 depicts (source: NTAMC, POWERGRID), the actual maximum MVar injection on night off peak time of a typical day (06.12.21) from 220 kV to 400 kV network through 400/220 kV ICTs in NR states shown in **Figure 4-2**.

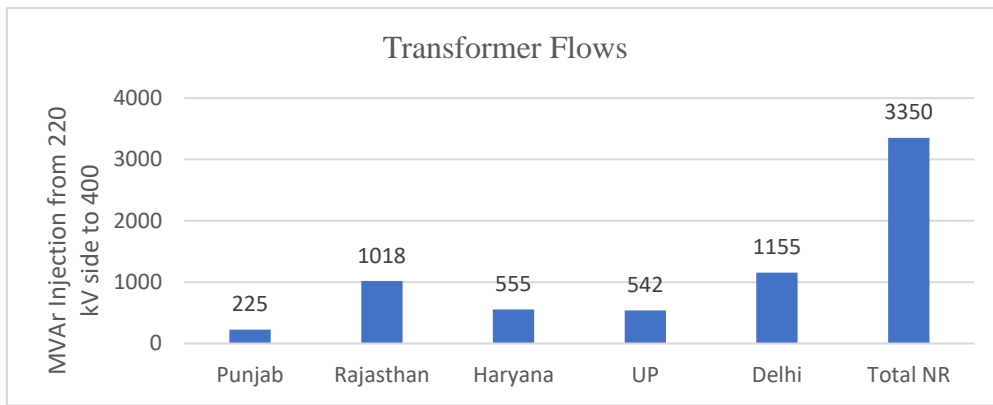

Figure 4-2: Maximum MVAR injection on a typical night

Figure 4-3 depicts total MVAR flows from 220 kV to 400 kV system through 400/220 kV ICTs in NR at different hours on the night of 06.12.21 (Figure 4-3)

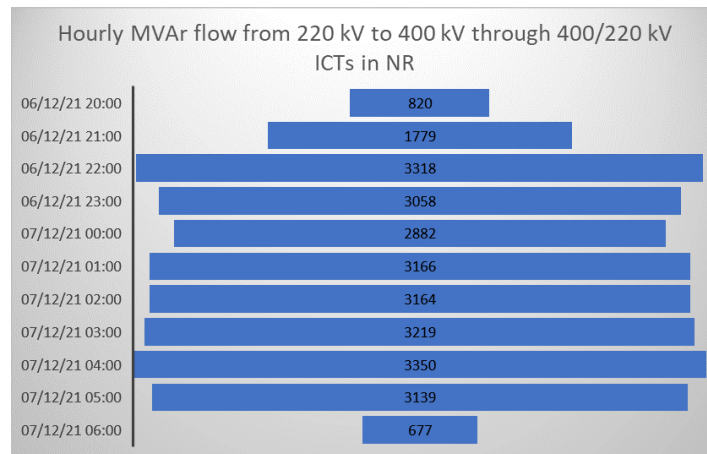

Figure 4-3: Total MVAR flow from 220 kV to 400 kV through 400/220 kV ICTs

From the analysis it was also emerged that in most of the substations reactive power is injected from 220 kV side through 400/220kV transformer due to inadequate reactive compensation in STU system.

Based on data received regarding existing/planned reactors and space availability at various substations, comprehensive reactive compensation studies were carried out for winter off-peak scenario of the year 2026-27. Based on the studies, following pockets were identified wherein reactive compensation measure is required to control high voltages and accordingly, new 420kv bus reactors are proposed to mitigate above high voltage issue. Details are as under

S.No.	Pocket/State	No of Substations on which HV observed in studies	HV observed in operational feedback report (GRID INDIA)	New 125MVA (420kV) bus reactors proposed based on studies	Remarks
1	Punjab	15 nos. (all 400kV substations)	9 nos.	4 nos. (Makhu, Rajpura, Mukatsar/ Behman Singh (Malkana), and Dhanansu)	High voltage observed in night off peak scenario of Q1 (Apr-Jun), Q3(Sep-Dec) and Q4(Jan-Mar) (more prevailing in winters) due to large variation in demand from peak paddy season in monsoon (14GW) to winter night off (3.5GW)
2	Haryana	3 nos.	12 nos. (on most of 400kV substations)	4 nos. (Deepalpur, Nuhiyanwali, Kaboolpur and Nawada)	High voltage observed in night off peak scenario of Q1 (Apr-Jun), Q3(Sep-Dec) and Q4(Jan-Mar) (more prevailing in winters) due to large variation in demand from evening peak demand in summers (12GW) to winter night off (3.8GW)
3	Delhi	-	5 nos.	-	High voltage observed in night off peak scenario of Q1 (Apr-Jun), Q3(Sep-Dec) and Q4(Jan-Mar) (more prevailing in winters) due to large variation in demand from evening peak demand in summers (7.5GW) to winter night off (1.5GW) over the year
4	Uttar Pradesh	3 nos	3 nos.	2 nos. (Badaun and Maheba)	
5	Rajasthan	-	3 nos.	-	
6	Himachal Pradesh	8 nos.	4 nos.	-	In winter season (Q3 and Q4) due to less availability of water as well as less demand in Northern region, hydro generation is minimally dispatched and few are operated in synchronous condenser mode. At present, high voltages are observed in some of substations of
7	Uttarakhand	10 nos.	-	-	
8	J&K	1 no.	-	1 no. (Pipalkoti)	

S.No.	Pocket/State	No of Substations on which HV observed in studies	HV observed in operational feedback report (GRID INDIA)	New 125MVar (420kV) bus reactors proposed based on studies	Remarks
					J&K/HP/Uttarakhand. However, with envisaged hydro generation in next 4-5 years i.e. Pakaldul, Kiru, Kwar, Ratle, Shangtong, Tapovan Vishnugarh, Vishnugad Pipalkoti, Tehri PSP, Luhri St-I, II, Sunni Dam etc., critical high voltages are observed in studies.

With above proposed reactive compensation, it was observed that, voltages on all EHVAC substations of High voltage pockets is within limit (≤ 1.03 pu).

Observations were received with GRID INDIA, CEA, PSTCL and HVPN and discussed in 8th CMETS-NR meeting. It was decided that stakeholders' comments on studies and on proposed bus reactors at various STU substations will be incorporated suitably and revised proposal along with reply of above observations will be shared shortly for finalization of proposal for installation of bus reactors to control high voltage in NR grid.

In line with discussion held in the 3rd & 4th NRPC (TP) meeting, proposal for line reactive compensation on 400kV transmission lines (ISTS) was also discussed. It was deliberated that 400kV D/c (Twin moose) line of 200-240km line length typically has a line rise (Ferranti rise) of 10-14kV (without reactors) at open end during line charging. In addition, source rise will be added in total rise. In above scenario, during line charging of transmission lines of 200-240km length, voltage may breach permissible steady stage voltage limit of 420kV due to consistently higher bus voltage (>410 kV). Further, due to such high voltage during charging events, issues are also observed in line equipment healthiness.

In Northern region, ISTS lines of more than 200 km line length but without any line reactive compensation have been analyzed. As informed by POWERGRID, space was not available for placement of line reactive compensation in substations for some of the lines. In above meeting, it was deliberated that based on information on availability of space in substation for placement of line reactive compensation, analysis has been carried out for following lines

- 400kV Mainpuri- Ballabgarh D/c line (236 km)
- 400kV Kanpur- Allahabad S/c line (225 km)
- 400kV Agra- Bhiwadi ckt -2 (209 km)

After deliberations, it was decided and agreed in 8th CMETS-NR meeting that above proposed scheme (bus+line reactors) may be segregated in two phases. In Phase-I, being an urgent requirement, line reactor proposal was agreed. Details of the scheme is as under:

- I. Installation of 50 MVAR switchable line reactor at Mainpuri end and fixed 50MVAR line reactor at Ballabgarh end on 400 kV Mainpuri- Ballabgarh D/c line - 236 km
- II. Installation of 50 MVAR switchable line reactor at Allahabad end on 400 kV Kanpur-Allahabad S/c line - 225 km
- III. Installation of 50 MVAR line reactor at Bhiwadi end for uncompensated circuit of 400kV Agra- Bhiwadi D/c line - 209 km

4.4.2 Rajasthan

A. Transmission system for evacuation of power from Rajasthan REZ Ph-IV (Part-1) (Bikaner Complex)

Transmission system for evacuation of power from Rajasthan Solar energy zones was evolved in various phases i.e Phase-I (8.9 GW), Phase-II (8.1 GW) & Phase-III (20 GW). The Ph-I transmission scheme is already commissioned whereas Ph-II is under various stages of implementation. The phase-III scheme is under tendering stage.

Further, MNRE vide letter No. 367-13/1/2021-GEC dated 15.02.2022 addressed to Joint Secretary (Trans), MoP, had forwarded the Renewable Energy Zones (REZs) identified by MNRE/SECI with a total capacity of 181.5 GW for likely benefits by the year 2030. Transmission plan has to be prepared for the identified RE zones. These REZ's are located in eight states, out of which 75 GW REZs includes state of Rajasthan comprising of 15 GW Wind and 60 GW Solar potential.

District-wise breakup of identified RE Zones (potential) in NR is given below :

State	District	Potential (GW)		Evacuation capacity to be planned (GW)
		Wind	Solar	
Rajasthan (75 GW)	Sanchoe, Sirohi, Jalor, Pali, Ajmer, Bikaner, Nagaur(non GIB Zone)	-	30	16
	Barmer, Jaisalmer, Jodhpur (GIB Zone)	15	30	32

Accordingly, a Comprehensive transmission scheme evolved for evacuation of 75GW RE from Rajasthan. Out of above comprehensive scheme, transmission scheme is evolved for about 8GW (Solar) in Bikaner complex (14 GW potential along with 6 GW BESS) in Rajasthan RE. At Bikaner-II PS, St-II Connectivity for 5.6 GW RE, against the potential of 1.9 GW (revised from 2.9GW identified under Ph-II), is already received. Accordingly, BESS may not be accounted for net dispatch at Bikaner-II PS while evolving the evacuation scheme and evacuation for additional 3.7 GW capacity is required from Bikaner-II PS. For 7GW additional solar potential at Bikaner-III along with 3GW BESS, evacuation system (4 GW) shall also be

required. Further details of St-II connectivity and LTA received in Bikaner complex is as under:

Pooling Station	St-II Connectivity received (MW)	LTA received (MW)
Bikaner	3875	3275
Bikaner-II	5575	1500
Bikaner-III	1060	-

The evacuation system planned earlier in Ph-I, II, III from Bikaner complex was adequate for evacuation of about 4.8 GW RE potential from Bikaner complex. However, recently due to restrictions in GIB area, CTU has received more no. of connectivity applications in Bikaner complex. Stage-II connectivity received at Bikaner (PG) & Bikaner-II PS has already exceeded the envisaged potential in Bikaner complex as part of Ph-I (2.9 GW) and Ph-II (1.9 GW) potential.

Upon grant of about 5.575 GW St-II Connectivity, in the 5th & 6th Consultation Meeting for Evolving Transmission Schemes in Northern Region, no further grant for St-II connectivity at 400/220kV Bikaner-II was decided. However, to effect LTA of entire Stage-II grant at Bikaner-II, additional corridors shall need to be planned from Bikaner-II PS. Further, as Bikaner and Bikaner-II PS are interconnected, power flow on interconnection is influenced by RE generation dispatched at each Pooling station as cumulative St-II connectivity granted for about 10 GW (Incl. possible enhancement) on both the pooling stations. Considering space limitation of 400kV bays for additional corridors as well as 765/400kV ICTs at Bikaner PS, there is limitation on evacuation of power from Bikaner PS.

Accordingly, deliberations were held in 8th Consultative Meeting for Evolving Transmission Systems in Northern Region (CMETS-NR) held in 30.06.22. In the meeting, comments of stakeholders i.e. HVPN, PSTCL, GRID INDIA were discussed. Based on discussions, revised study files for February & June solar max scenario shared to all constituents. Additionally P-V, Q-V analysis for highly loaded 765kV lines also carried out to assess system stability under various contingencies.

Considering grant of connectivity to new RE generators in Bikaner complex (incl. Bikaner-III) as well as for evacuation of power beyond Bikaner complex (Bikaner/Bikaner-II/Bikaner-III PS), following transmission scheme was agreed for evacuation of power from Rajasthan REZ Ph-IV (Part-1) [Bikaner complex] in the 8th & 9th CMETS-NR meeting.

Scope of work along with tentative Cost and Implementation time-frame (Transmission system for evacuation of power from Rajasthan REZ Ph-IV (Part-1))

Sl, No	Scope of the Transmission Scheme
1	Establishment of 6x1500 MVA (along with 1x500MVA spare unit), 765/400 kV & 5x500 MVA^ 400/220 kV Bikaner-III Pooling Station along with 2x330 MVar

Sl, No	Scope of the Transmission Scheme
	<p>(765kV) Bus Reactor (along with 110MVA spare unit) & 2x125 MVA (420kV) Bus Reactor at a suitable location near Bikaner (Assuming 2 GW injection at 220 kV level and 2 GW injection at 400 kV level)</p> <p><u>Future provisions at Bikaner-III PS:</u></p> <p>Space for</p> <ul style="list-style-type: none"> ➤ 765/400kV ICT along with bays- 1 no. ➤ 765 kV line bays along with switchable line reactors – 4 nos. ➤ 765kV Bus Reactor along with bay: 1 no. ➤ 400 kV line bays along with switchable line reactor –4 nos. ➤ 400 kV line bays–4 nos. ➤ 400/220kV ICT along with bays -5 nos. ➤ 400 kV Bus Reactor along with bay: 1 no. ➤ 400kV Sectionalization bay: 2 sets ➤ 220 kV line bays for connectivity of RE Applications -12 nos. ➤ 220kV Sectionalization bay: 3 sets ➤ STATCOM (2x±300MVA) along with MSC (4x125 MVA) & MSR (2x125 MVA)
2	Augmentation with 400/220 kV, 5x500 MVA [^] ICT at Bikaner-II PS
3	Augmentation with 765/400 kV, 1x1500MVA ICT (4 th) at Bikaner (PG)
4	LILO of both ckts of 400kV Bikaner (PG)-Bikaner-II D/c line at Bikaner-III PS (~20 km)
5	Bikaner-II PS – Bikaner-III PS 400 kV D/c line (Quad) (~30 km)
6	<p>Establishment of 765/400 kV, 4x1500 MVA (along with 1x500MVA spare unit) Neemrana-II S/s along with 2x330 MVA (765kV) Bus Reactor (along with 110MVA spare unit) & 2x125 MVA (420kV) Bus Reactor at a suitable location near Neemrana</p> <p><u>Future provisions at Neemrana-II S/s:</u></p> <p>Space for</p> <ul style="list-style-type: none"> ➤ 765/400kV ICT along with bays- 2 ➤ 765 kV line bays along with switchable line reactors – 6 ➤ 765kV Bus Reactor along with bay: 1 nos. ➤ 400 kV line bays along with switchable line reactor –6 ➤ 400 kV Bus Reactor along with bays: 1 no. ➤ 400kV Sectionalization bay: 2 sets
7	Bikaner-III – Neemrana-II 765 kV 2xD/c line (~350 km) along with 330 MVA switchable line reactor for each circuit at each end
8	Neemrana-II- Bareilly(PG) 765 kV D/c line (~350 km) along with 330 MVA switchable line reactor for each circuit at each end
9	Neemrana-II -Kotputli 400 kV D/c line (Quad)(~70 km)

Sl, No	Scope of the Transmission Scheme
10	Augmentation by 400/220 kV, 1x500 MVA (3rd) ICT at Kotputli (PG)
11	LIL0 of both ckts of Sohna Road(GPTL)-Gurgaon(PG) D/c line at Neemrana-II S/s (~85 km)
12	220 kV line bays at Bikaner-III PS(6 no.) for interconnection of RE Projects

^incl 1x500MVA ICT to fulfill 'N-1' requirement

Implementation time-frame : 24 months from allocation of project

Estimated Cost (Rs. Cr) : 13,460

However, out of above agreed scheme, 765/400kV ICT (4th) at Bikaner (PG) S/s and 400/220 kV, 5x500 MVA ICT at Bikaner-II PS may be taken up based on evacuation requirement beyond Bikaner/Bikaner-II PS. The scheme is also agreed in 56th NRPC and 9th NCT meeting. The schematic of agreed scheme is as under (**Figure 4-4**)

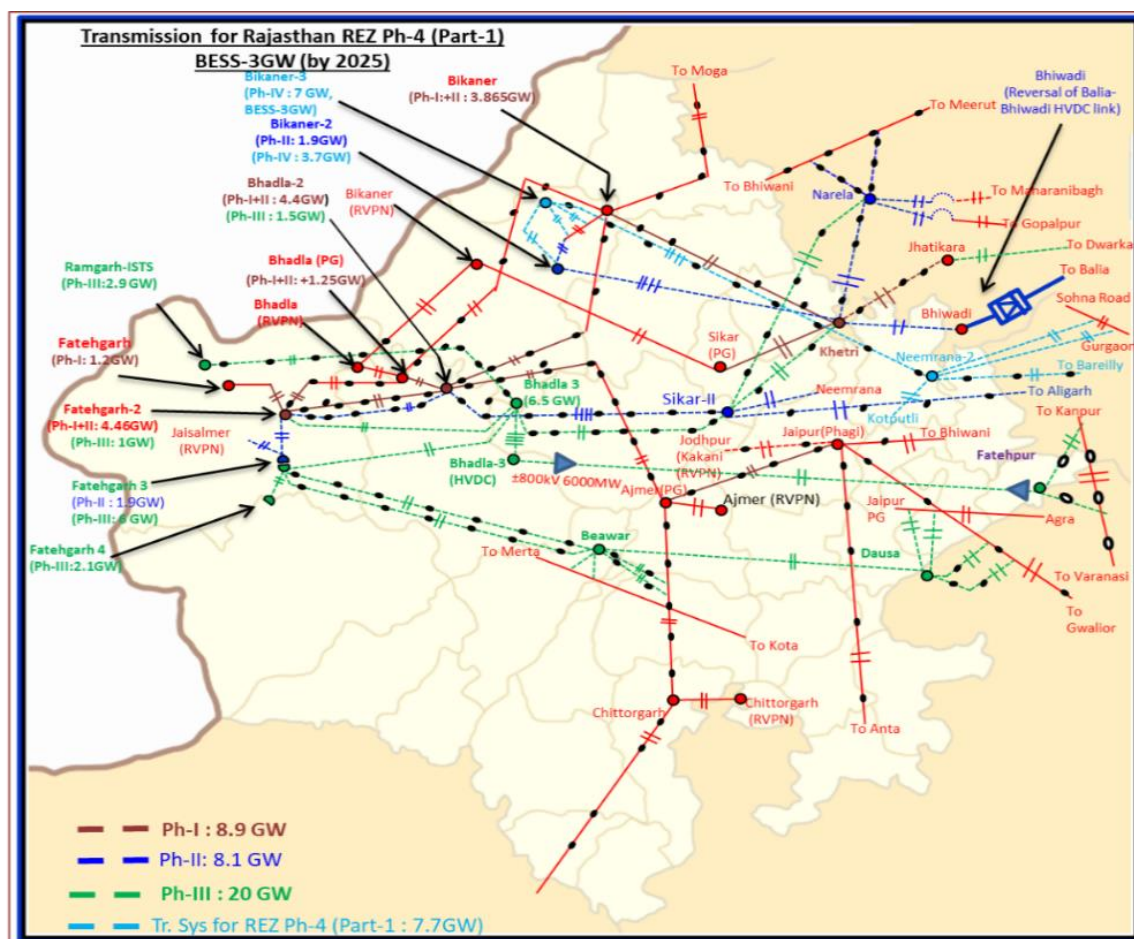

Figure 4-4: Tr. system for evacuation of power from Rajasthan REZ Ph-IV (Part-1)

(a) Implementation of "N-1" contingency at RE pooling substations in NR

As per CEA transmission planning criteria, section 16.2 “The ‘N-1’ criteria may not be applied to the immediate connectivity of wind/solar farms with the ISTS/Intra-STS grid i.e. the line connecting the farm to the grid and the step-up transformers at the grid station.” The above criteria is also followed in planning of transmission system for integration of renewable energy zones in Rajasthan.

POWERGRID vide letters dated 17th May 2022 & 19th May 2022 informed that as per the current practice, N-1 criteria is not being implemented at planning stage of network with respect to step up transformers at RE pooling stations in Rajasthan (Bhadla-2, Fatehgarh-2 & Bikaner). Due to this, outage of any transformer in above stations will result into overloading of other transformers leading to cascaded tripping on overload/higher temperature and may adversely impact both RE generation as well as health of the transformers. In view of the above, POWERGRID requested CTU to implement additional 400/220kV ICTs at RE pooling stations to meet the N-1 criteria for smooth evacuation of power. POWERGRID also recommended that, N-1 criteria may be taken into consideration during planning stage for upcoming RE pooling stations.

GRID INDIA suggested that high RE capacity Substations must have N-1 compliance at 400/220 kV level i.e., Fatehgarh-II (both sections)/Fatehgarh-III PS, Bhadla-II PS etc. for which revised transmission planning criteria must have suitable provisions. NRPC agreed in the meeting that CTU may explore possibility of ensuring N-1 compliance at 400/220kV RE pooling stations with higher RE capacity on case-to-case basis and take up the ICT augmentation proposal for approval on priority.

In the Draft CEA Transmission planning criteria-2022, it is mentioned that “N-1 reliability criteria may be considered for ICTs at the ISTS /STU pooling stations for renewable energy-based generation of more than 1000 MW after considering the capacity factor of renewable generating stations.”

POWERGRID vide mail dated 26.05.2022 confirmed the availability of space for implementation of additional ICTs at each 400/220 kV sections of Fatehgarh-2, Bhadla-2 & Bikaner PS along with Cable/GIS duct connection requirement.

Considering the security and reliability of the system, it was agreed in 8th & 9th CMETS-NR meeting to implement additional ICTs in each 400/220 kV sections of the RE pooling stations in order to meet the N-1 criteria as well as to meet the evacuation requirement. Scheme was agreed to be implemented in phases as under:

A) ICTs agreed to be taken up for implementation as system strengthening scheme on urgent basis

1. Augmentation with 400/220kV, 1x500MVA Transformer at Fatehgarh-2 PS (6th ICT at Section-1 with cable/GIS duct connection at 220kV side)
2. Augmentation with 400/220kV, 1x500MVA Transformer at Bikaner PS (3rd ICT)

B) ICTs agreed to be taken up for implementation on receipt of commensurate LTA quantum at RE pooling stations as shown below

1. Augmentation with 400/220kV, 1x500MVA Transformer at Bhadla-2 PS (4th ICT at Section-1A)

Implementation Timeframe: 15 months from the date of allocation of project or evacuation requirement beyond 1000 MW at 220kV level of Bhadla-2(Section-1A) whichever is later.

2. Augmentation with 400/220 kV 1x500 MVA (6th) ICT at Fatehgarh-2 PS (In Section-1A with cable/GIS duct connection at 220kV side)

Implementation Timeframe: 15 months from the date of allocation of project or evacuation requirement beyond 2000 MW at 220kV level of Fatehgarh-2(Section-1A) or LTA grant schedule of M/s Eden RE Bercy (Mar'24) whichever is later.

3. Augmentation with 400/220 kV 1x500 MVA(4th) ICT at Bikaner PS

Implementation Timeframe: 15 months from the date of allocation of project or evacuation requirement beyond 1000 MW at 220kV level of Bikaner PS whichever is later.

4. Augmentation with 400/220kV, 1x500MVA (6th) ICT at Bhadla-2 PS (In Section-1 with cable/GIS duct connection at 220kV side)

Implementation Timeframe 15 months from the date of allocation of project or evacuation requirement beyond 2075 MW at 220kV level of Bhadla-II PS whichever is later.

For optimal utilization of ICTs, it is recommended that Schedule for Part-B for S.No. 1,3, and 4 ICTs to be matched with RE generation schedule. Part-A of above scheme was also agreed in 56th NRPC meeting

(b) Transmission system for evacuation of power from Rajasthan REZ Ph-IV (Part-2: 7.5GW) (Jaisalmer/Barmer Complex)

Ministry of Power vide letter No. 15-3/2017-Trans (part 1) dated 7th December, 2021, had constituted a Committee on Transmission Planning for RE under the Chairmanship of Chairperson, CEA, for planning of the requisite Inter- State Transmission System required for the targeted RE capacity by 2030.

Renewable Energy Zones (REZs) were identified by MNRE/SECI with a total capacity of 181.5 GW for likely benefits by the year 2030 in eight states, which includes 75 GW REZ potential in Rajasthan comprising of 15 GW Wind and 60 GW Solar. Accordingly, a Comprehensive transmission scheme was evolved for evacuation of 181.5 GW RE power including 75GW from Rajasthan. As part of committee report as well as MNRE/SECI inputs, 12GW potential (Wind: 6GW, Solar: 6GW) along with 4GW BESS envisaged at Fatehgarh-IV in Jaisalmer complex by 2030. Out of 12GW potential, 8GW potential (Wind: 4GW, Solar: 4GW) along with 2GW BESS considered by 2027 at Fatehgarh-IV PS. Similarly, 7GW potential (Wind: 3GW, Solar: 4GW) along with 1.5GW BESS envisaged at Barmer-I in Barmer complex by 2030. Out of 7GW potential, 6GW potential (Wind: 3GW, Solar: 3GW) along with 1GW BESS considered in Barmer-I by 2027.

BESS of 3GW (Fatehgarh-IV : 2GW, Barmer-I : 1GW) is considered for net dispatch at Fatehgarh-IV PS and Barmer-I PS while evolving the evacuation scheme

Pooling Station	Total RE Potential (by 2030)		RE Potential (by 2027)	Net (Max) Dispatch Considered by 2027(GW)
	Source	Capacity (GW)	Capacity (GW)	
Fatehgarh-IV	Wind	6	4	4
	Solar	6	4	
	BESS	4	2	
Barmer-I	Wind	3	3	3.5
	Solar	4	3	
	BESS	1.5	1	
			Total (GW)	7.5

As part of Rajasthan REZ Ph-III (20GW) transmission system, 400/220kV Fatehgarh-IV PS and associated transmission system is already under bidding. The evacuation system planned earlier in Ph-III from 400/220kV Fatehgarh-IV PS is adequate for evacuation of about 2 GW RE capacity. Considering above, space provision for separate 765/400//220kV (Section-2) at Fatehgarh-IV PS was already approved in 8th NCT meeting held on 25.03.22

At present, St-II Connectivity for about 3.1 GW RE, against the potential of 2.1 GW (under Ph-III), is already received at Fatehgarh-IV PS and Stage-II connectivity granted/received has already exceeded the envisaged potential of Fatehgarh-IV PS [Ph-III potential: 2.1 GW]. Considering grant of connectivity to new RE generators at Fatehgarh-IV PS as well as for evacuation of power from Fatehgarh-IV PS beyond 2 GW in Jaisalmer Complex and Barmer-I PS in Barmer complex, 765kV high capacity corridors will be required from above pooling stations.

Accordingly, system studies were carried out and study plots along with network files were sent to all stakeholders dated 30.11.22. A Joint Study Meeting was held in virtual mode on 05.12.22 with NRPC, CEA, GRID-INDIA (Formerly known as GRID INDIA), RVPN, HVPN, UPPTCL, PSTCL and other STUs of Northern region to finalize the Transmission system for evacuation of power from Rajasthan REZ Ph-IV (Part-2 :7.5GW) (Jaisalmer/Barmer Complex).

Based on observations received from Stakeholders as well as discussion held in joint study meeting, CTU shared the revised study files along with evening peak/off peak files to all constituents on 16.12.22 incorporating the suggestions and inputs from UP, Punjab & GRID-INDIA/NRLDC.

In Feb solar max scenario (revised case) loading of 400kV RAPP- Shujalpur D/c line is marginally higher (about 910MW) in N-1 contingency. The loading of above line will be reviewed with progress of RE generation projects at Rajasthan and strengthening requirement will be identified later, if required. In revised and additional cases, line loadings of other lines in above RE complex were found to be in order as well as voltages were within limits on all substations.

Subsequently, the scheme was discussed and agreed in the 14th CMETS-NR held on 23.12.22. In the meeting, RVPN confirmed that there will be no drawl requirement in Jalore area in future. The transmission system for WR portion was discussed in a meeting amongst CEA, CTUIL, MPPTCL and GRID-INDIA on 01.12.2022, wherein the above system was in-

principally agreed. The scheme was further agreed in 13th CMETS-WR meeting held on 08.12.2022 (Figure 4-5)

Scope of work along with tentative Cost and Implementation time-frame:

NR Portion

Sl. No.	Scope of the Transmission Scheme	Estimated Cost (Rs Cr)
1	<ul style="list-style-type: none"> Establishment of 4x1500 MVA, 765/400 kV & 5x500 MVA[^], 400/220 kV Fatehgarh- IV (Section-2) Pooling Station along with 2x240 MVA_r (765 kV) Bus Reactor & 2x125 MVA_r (400 kV) Bus Reactor * 6 nos. of 220 kV line bays at Fatehgarh-IV PS (for RE connectivity) 220kV Sectionalization bay (1 set) along with BC (2 nos.) and TBC (2 nos.) at Fatehgarh- IV (Section-2) Pooling Station <p><i>Future provisions at Fatehgarh-IV PS is already approved in 8th NCT meeting dated 25.03.22</i></p> <p><i>[^]incl 1x500MVA ICT to fulfill 'N-1' requirement</i></p> <p><i>*Incl. spare one ICT unit (500MVA) and spare one reactor unit (80MVA_r) at Fatehgarh-IV PS</i></p>	871.91
2	Fatehgarh-IV (Section-2) PS – Bhinmal (PG) 400 kV D/c line (Twin HTLS) along with 50 MVA _r switchable line reactor at each end (~200 km)	772.78
3	LILO of both ckts of 765 kV Fatehgarh-III- Beawar D/c line(2 nd) at Fatehgarh-IV (Section-2) PS along with 330 MVA _r switchable line reactors at Fatehgarh-IV PS end of each ckt of 765 kV Fatehgarh-IV- Beawar D/c line (formed after LILO) (~15 km) *	440.82
	<i>*Incl spare one reactor unit (110MVA_r) at Fatehgarh-IV PS</i>	
4	<ul style="list-style-type: none"> Establishment of 4x1500 MVA, 765/400 kV & 5x500 MVA[^], 400/220 kV Barmer-I Pooling Station along with 2x240 MVA_r (765 kV) Bus Reactor & 2x125 MVA_r (400 kV) Bus Reactor* 6 nos. of 220 kV line bays at Barmer-I PS (for RE connectivity) 220kV Sectionalization bay (1 set) along with BC (2 nos.) and TBC (2 nos.) at Barmer-I PS <p><u>Future provisions</u></p> <p><u>Space for</u></p> <ul style="list-style-type: none"> ➤765/400kV ICT along with bays- 2 no. ➤765 kV line bays along with switchable line reactors – 4 nos. ➤765kV Bus Reactor along with bay: 1 no. ➤400 kV line bays –4 ➤400 kV line bays along with switchable line reactor –4 nos. ➤400/220kV ICT along with bays -5 nos. ➤400 kV Bus Reactor along with bay: 1 no. ➤400kV Sectionalization bays: 2 sets ➤220 kV line bays for connectivity of RE Applications -8 nos. ➤220kV Sectionalization bay: 2 sets ➤BC (2 nos.) & TBC (2 nos.) ➤STATCOM (2x±300MVA_r) along with MSC (4x125 MVA_r) & MSR (2x125 MVA_r) <p><i>[^]incl 1x500MVA ICT to fulfill 'N-1' requirement</i></p>	879.41

Sl. No.	Scope of the Transmission Scheme	Estimated Cost (Rs Cr)
	*Incl. spare one ICT unit (500MVA) and spare one reactor unit (80MVA) at Barmer-I PS	
5	Fatehgarh-III (Section-2) PS – Barmer-I PS 400 kV D/c line (Quad) (~50 km)	294.95
6	Establishment of 2x1500 MVA, 765/400 kV Substation at suitable location near Jalore PS along with 2x240 MVA (765 kV) & 2x125 MVA (400 kV) Bus Reactor * <u>Future provisions at Jalore S/s:</u> Space for <ul style="list-style-type: none"> ➤ 765/400kV ICT along with bays- 4 ➤ 765 kV line bays along with switchable line reactors – 4 ➤ 765kV Bus Reactor along with bay: 1 nos. ➤ 400 kV line bays along with switchable line reactor –4 ➤ 400 kV line bays –4 ➤ 400 kV Bus Reactor along with bay: 1 no. ➤ 400kV Sectionalization bay: 2 sets ➤ 400/220kV ICT along with bay - 6 no. ➤ 220kV line bays -10 ➤ 220kV Sectionalization bay: 2 sets ➤ BC (3 nos.) & TBC (3 nos.) ➤ STATCOM (2x±300MVA) along with MSC (4x125 MVA) & MSR (2x125 MVA) * Incl. spare one ICT unit (500MVA) and spare one reactor unit (80MVA) at Jalore PS	388.99
7	Fatehgarh-IV (Section-2) PS – Jalore PS 765 kV D/c line along with 240 MVA switchable line reactor for each circuit at each end (~200 km)	1921.8
8	Barmer-I PS– Jalore PS 765 kV D/c line along with 330 MVA switchable line reactor for each circuit at Jalore PS end (~165 km) * *Incl spare one reactor unit (110MVA) at Jalore end	1591.85
9	Jalore PS-Chittorgarh (PG) 400 kV D/c line along with 50 MVA switchable line reactor for each circuit at each end (Quad) (~200 km)	1071.73
10	Jalore PS- Mandsaur PS 765 kV D/c line along with 330 MVA switchable line reactor for each circuit at each end (~320 km)	2967.04
11	Beawar- Mandsaur PS 765 kV D/c line along with 240 MVA switchable line reactor for each circuit at each end (~250 km)	2348.11
12	Augmentation by 1x1500 MVA, 765/400 kV ICT at Fatehgarh-II PS (7 th)	106.67
	Estimated Cost	13656.05

WR Portion

Sl. No.	Scope of the Transmission Scheme	Estimated Cost (Rs Cr)
1	Establishment of 765kV Mandsaur Pooling Station along with 2x330MVAr (765kV) Bus Reactor	143.43
2	Mandsaur PS – Indore(PG) 765 kV D/c Line (200km) along with 1x330MVAr switchable line reactor (SLR) on each ckt at Mandsaur end	1954.44
3	Establishment of 765/400 (2x1500MVA) 400/220 (2x500MVA) & 220/132kV (3x200MVA) Kurawar S/s with 2x330MVAr 765kV bus reactor and 1x125MVAr 420kV bus reactor	559.33
4	Mandsaur – Kurawar 765kV D/c line (~235km.) with 240MVAr switchable line reactors at both ends	2307.16
5	LILO of Indore – Bhopal 765kV 765kV S/c line at Kurawar (LILO length 15km.)	189.32
6	Kurawar – Ashtha 400kV D/c (Quad ACSR/AAAC/AL59 moose equivalent) line (65km.)	381.20
7	LILO of one circuit of Indore – Itarsi 400kV D/c line at Astha (LILO length 30km.)	177.91
8	Shujalpur – Kurawar 400kV D/c (Quad ACSR/AAAC/AL59 moose equivalent) line (40km.)	254.32
	Estimated Cost	5967.12

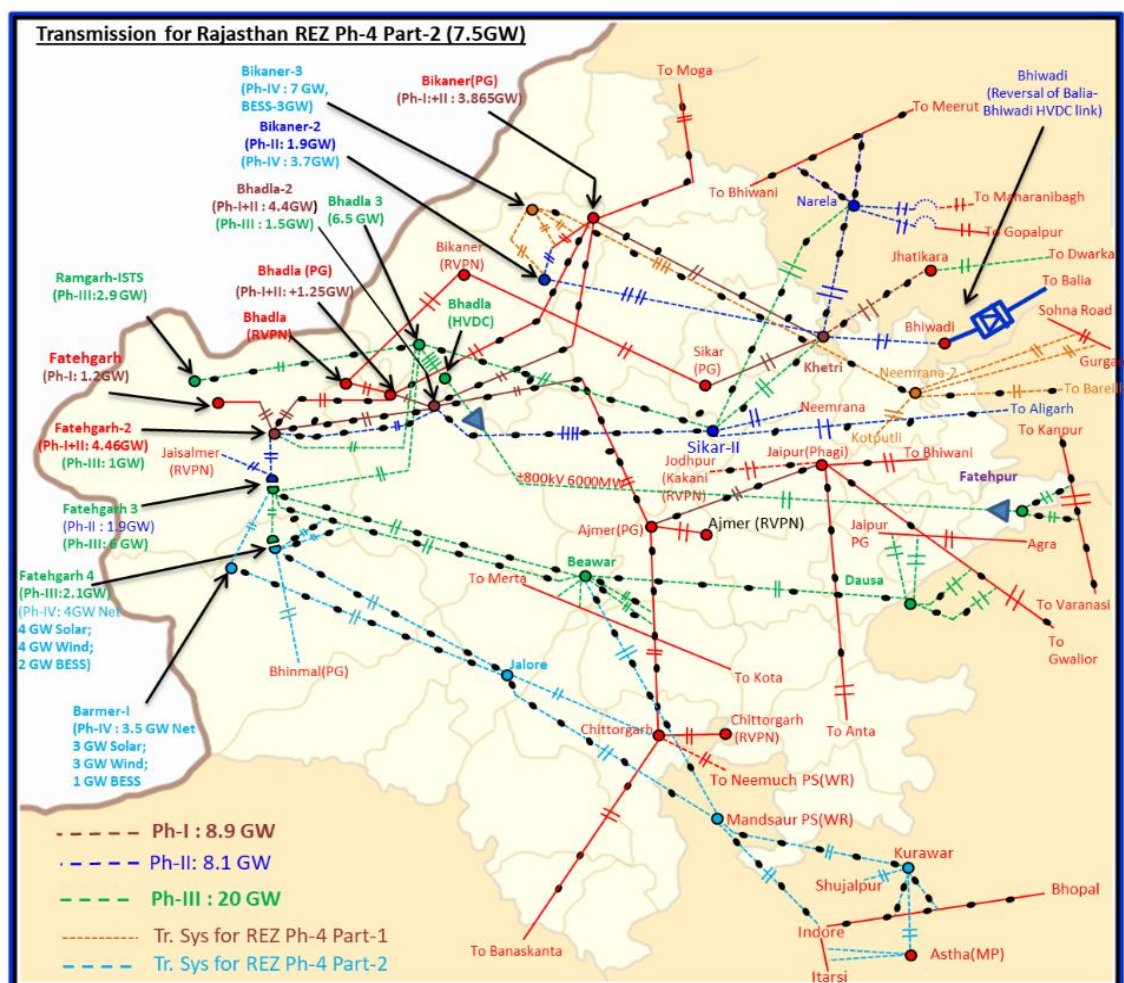

Figure 4-5: Tr. system for evacuation of power from Rajasthan REZ Ph-IV (Part-2)

The scheme is also agreed in 61th NRPC meeting recently and to be taken up in NCT meeting for approval.

4.4.3 Punjab

A. Enhancement of ATC/TTC for Punjab due to unprecedented load growth of summer/ paddy season

In 57th NRPC meeting held on 31.08.2022, PSTCL informed that the demand of the state during the current paddy season has been recorded as 14,208 MW by the SLDC which has been met successfully with ATC/TTC limits of 8500/9000 and full generation at 400kV/220 kV/132kV generating nodes. In order to meet the state demand for paddy 2023, ATC limit is required to be increased to at least 10,000 MW. PSTCL also informed that the peak demand for next summer/paddy season is projected as 15,500 to 16,000 MW, which is likely to reach up to 18,000 MW by the year 2025. Hence, to meet the increasing power demand, immediate enhancement of ATC/TTC limits up to 10,000/10,500 MW and subsequently to 12,000 MW in the next 3 years is required.

In the NRPC meeting, PSTCL informed that for the upcoming paddy season 2023, they have carried out load flow studies and proposed various transmission works at PGCIL substations for enhancing ATC/TTC limits to 10,000/10,500MW (considering 1000 – 1500 MW annual load growth for FY 2022-23). In the meeting it was stated that PSTCL may

also submit their consolidated proposal for ISTS works so that it can be taken up in ensuing CMETS-NR meeting for approval. Subsequently, PSTCL vide letter dated 06.09.2022 to CTU, requested for transformer augmentation and 220kV line bay implementation works in ISTS substations on priority. Details of ISTS works are as under:

(a) Augmentation of 1x500 MVA (3rd) ICT at 400/220 kV Patran substation

As per information provided by PSTCL, existing 2 Nos. 500 MVA ICTs at 400/220 kV Patran S/s are 'N-1' non-compliant. Considering the load growth of paddy/summer season in Punjab, 3rd 500 MVA ICT at 400/220 kV Patran S/s is required with the timeline of May 2024. GRID INDIA in its operational feedback report on transmission constraint (Apr-Jun'22) also highlighted that 400/220kV Patran ICT is on the verge of 'N-1' non-compliance. As per data received from GRID INDIA/NRLDC, loading pattern of Patran ICTs (Nov'21 onwards) is as shown below (Figure 4-6)

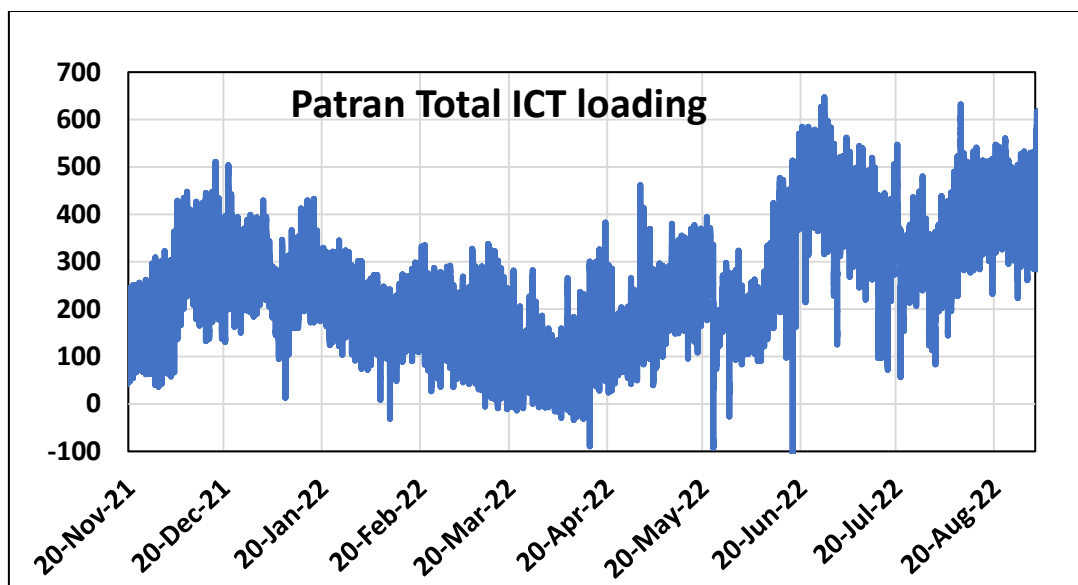

Figure 4-6: Loading of Patran ICTs (2x500 MVA)

From the loading pattern, it emerged that the loading of ICTs at Patran S/s is consistently in the range of 500-600 MW in paddy season (Jun-Aug) with peak loading of 646 MW against 1000MVA (about 65% loading). Considering the load growth as indicated by PSTCL outage of one 500 MVA ICT at Patran S/s, other ICT may become 'N-1' non-compliant in future. In the 198th OCC meeting held on 17.08.2022, NRLDC had also confirmed that the loading of 400/220kV ICT Patran S/s was close to N-1 limits. GRID INDIA/NRLDC also stated that augmentation of transformation capacity is required at Patran S/s

It was stated that Patran Transmission Company Limited (PTCL) (a part of Indigrd Investment Trust) vide mail dated 14.09.22 confirmed the availability of space for installation of 3rd 400/220kV ICT at Patran S/s.. Considering the unprecedented load growth in Punjab & request of PSTCL, following ISTS scheme was agreed for implementation (Figure 4-7)

Scope of work along with tentative Cost and Implementation time-frame

Sl. No.	Scope of the Transmission Scheme	Capacity/km	Implementation timeframe
1	Augmentation of Transformation Capacity by 1x500 MVA, 400/220kV ICT (3rd) at 400/220 kV Patran (GIS) S/s along with GIS duct (at 400kV and 220kV) in new diameter of ICT – Tie– Line.	500 MVA 400/220 kV ICT- 1no. 400 kV ICT bay (GIS) – 1 no. 400kV bay (GIS) for diameter completion for future line (duct upto outside GIS Hall) – 1 no 220 kV ICT bay (GIS) – 1 no.	21 months from the issue of OM
Total Estimated Cost:			INR 65.19 Crore

Note: Best efforts shall be carried out to implement the transmission scheme by 31.05.24 as per the request of PSTCL letter vide dated 06.09.22 and mail dated 01.11.2022.

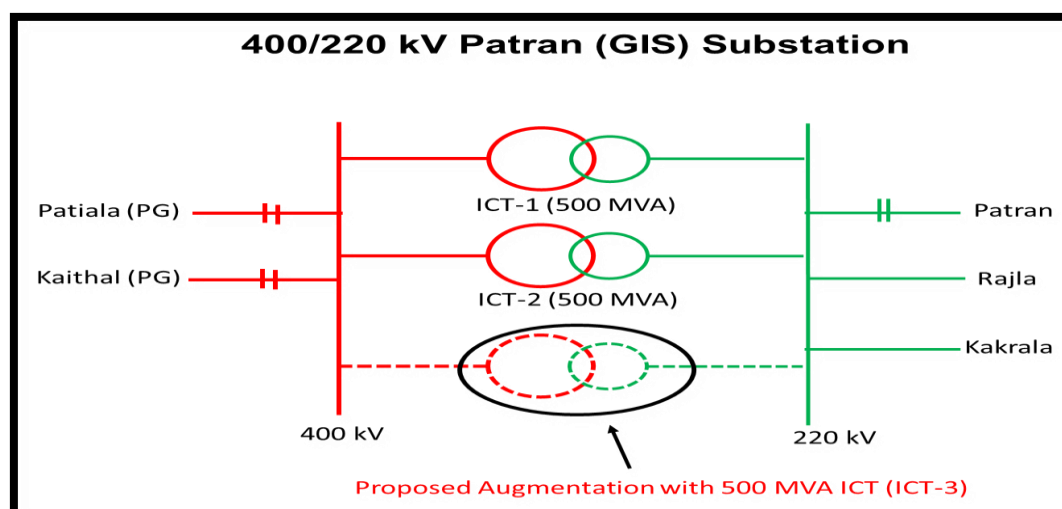

Figure 4-7: Schematic of 400/220kV Patran (GIS) S/s

(b) 2 Nos. of 220 kV bays at 400/220 kV Panchkula (Barwala) S/s for interconnection with 220 kV Dera Bassi substation

PSTCL in its letter informed that in order to meet with the unprecedented load growth in Zirakpur—Lalru—Dera Bassi belt and also to reduce the loading of Nalagarh—Mohali circuits, a D/c link between 220 kV Dera Bassi and 400/220 kV Panchkula (Barwala) is proposed with the timeline of May 2024. POWERGRID vide mail dated 14.09.22 also confirmed the availability of space for additional 2 no. of 220 kV line bays at 400/220 kV Panchkula S/s. PSTCL shall ensure OPGW requirement on 220kV Panchkula (PG) – Dera

Bassi line in line with MoP order dated 16.09.15 for reliable communication of SCADA data connectivity of nodes on OPGW network.

PSTCL was also requested to match transmission line i.e. 220 kV Dera Bassi - Panchkula(PG) D/c as per bays schedule. The agreed ISTS scheme is under (Figure 4-8)

Scope of work along with tentative Cost and Implementation time-frame

Sl. No.	Scope of the Transmission Scheme	Capacity/km	Implementation timeframe
1	Implementation of 2 nos. of 220 kV line bay at 400/220 kV Panchkula (Barwala) (PG) S/s for interconnection with 220 kV Dera Bassi S/s	220 kV line bay – 2 nos.	31.05.24
Total Estimated Cost:			INR 11.68 Crore

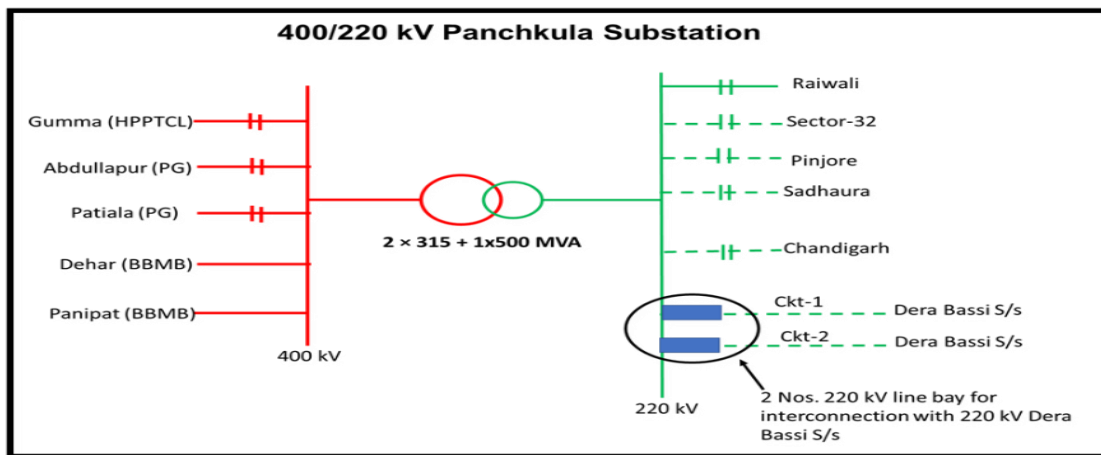

Figure 4-8: Schematic of 400/220kV Panchkula (S/s)

(c) Replacement of 1x315 MVA (3rd) 400/220kV ICT to 500 MVA at 400/220 kV Ludhiana (PG) S/s:

In the 4th NRPC(TP) meeting held on 05.10.21 and 12.10.21, replacement of one no. of 315 MVA ICT(ICT-2) at 400/220kV Ludhiana S/s with a 500 MVA ICT was agreed and was commissioned in May'22. With this augmentation, total transformation capacity at 400/220kV Ludhiana S/s is 1630 MVA (2x315 + 2x500 MVA). PSTCL vide their letter requested for replacement of one more 400/220kV, 315 MVA ICT at Ludhiana S/s. GRID INDIA in its operational feedback report on transmission constraint (Apr-Jun'22) also highlighted that 400/220kV Ludhiana ICTs is on the verge of 'N-1' non-compliance. As per data received from GRID INDIA/NRLDC, loading pattern of Ludhiana ICTs from May'22 onwards (after replacement of one 315 MVA ICT with a 500 MVA ICT) is as shown below (Figure 4-9)

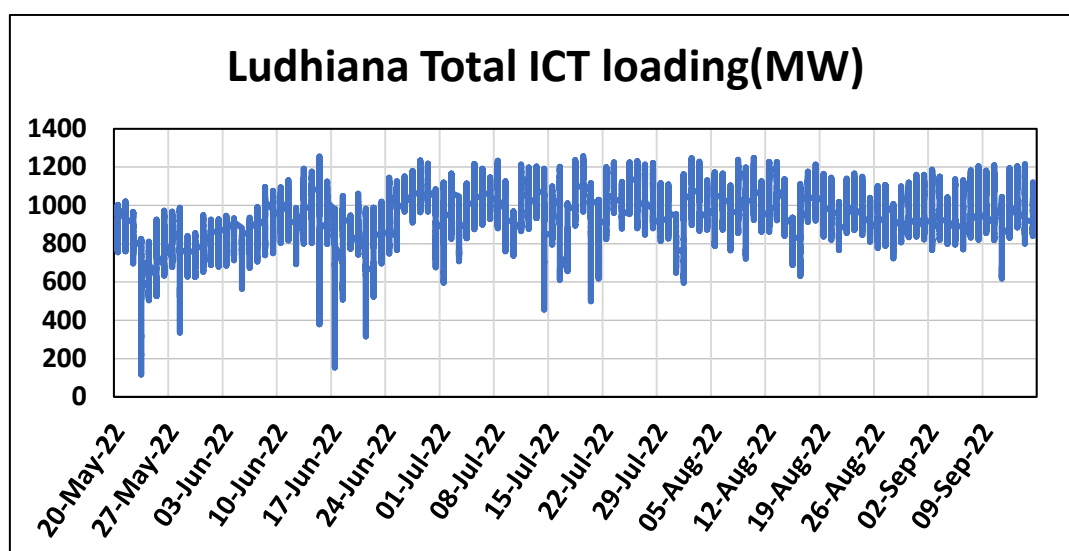

Figure 4-9: Loading of Ludhiana ICTs (1630MVA)

From the loading pattern, it emerged that the loading of ICTs at Ludhiana is consistently in the range of 1000-1200 MW in paddy season (Jun-Aug) with peak loading of 1257 MW against 1630MVA transformation capacity (~77% loading). Considering the load growth as indicated by PSTCL, outage of one 500 MVA ICT at Ludhiana, balance ICTs may become 'N-1' non-compliant in future. In the 198th OCC meeting held on 17.08.2022, NRLDC had also highlighted that the loading of 400/220kV ICTs at Ludhiana was close to N-1 limits.

POWERGRID vide mail 14.09.22 confirmed the feasibility to replace the existing 315 MVA ICT (1st or 3rd) at Ludhiana with a 500 MVA ICT. However, POWERGRID informed that currently ICT-1 tertiary is being used for auxiliary supply of SVC whereas ICT-3 tertiary is being used for station load at Ludhiana.

POWERGRID vide mail 10.10.22 informed that for Auxiliary supply arrangement for SVC during replacement of 315MVA ICT-1, it is proposed that 66kV Cable of approx. 250 Meter length may be considered from adjacent ICT-2 till ICT-1. It was decided that 315MVA ICT will be used as regional spare (Figure 4-10).

Scope of work along with tentative Cost and Implementation time-frame

Sl. No.	Scope of the Transmission Scheme	Capacity/km	Implementation timeframe
1	Replacement of 1x315 MVA 400/220kV ICT (ICT-1) at 400/220 kV Ludhiana (PG) S/s with 1x500 MVA 400/220kV ICT * *along with 66kV cable for shifting auxiliary supply to SVC from ICT-1 to ICT-2	500 MVA 400/220 kV ICT- 1no.	18 months from the issue of OM
Total Estimated Cost:			INR 26.98 Crore

Note : TSP may expedite the implementation of the above transmission scheme to the extent possible, as per the request of PSTCL vide letter dated 06.09.22 for implementation schedule of May'23 (reconfirmed to 31.05.23 vide mail dated 01.11.22)

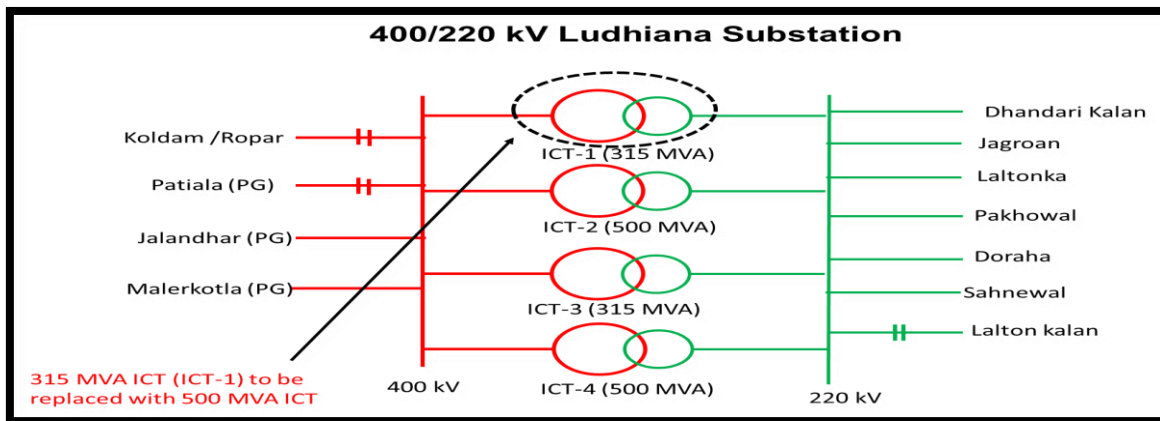

Figure 4-10: Schematic of 400/220kV Ludhiana S/s

(d) Replacement of 1x250 MVA, 400/220 kV ICT to 500 MVA at 765/400/220 kV Moga S/s

At present the total transformation capacity of 765/400/220kV Moga S/s is 1565 MVA (1x250+1x315+2x500). PSTCL requested to replace the 250 MVA ICT at Moga S/s with 500 MVA ICT. As per data received from GRID INDIA/NRLDC, loading pattern of Moga ICTs (Nov'21 onwards) is as shown below (Figure 4-11)

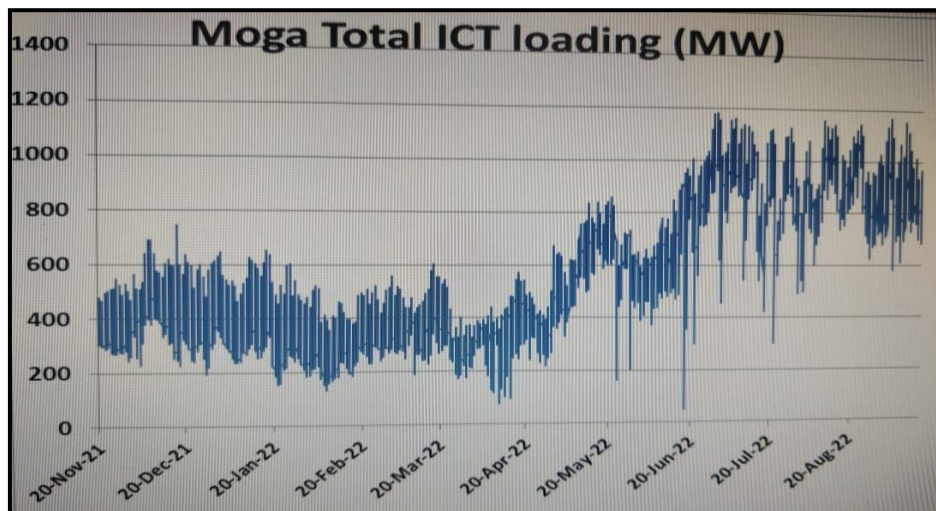

Figure 4-11: Loading of Moga ICTs (1565MVA)

From the loading pattern it emerged that the loading of ICTs at Moga is consistently in the range of 1000-1150 MW in paddy season (May'22 onwards) with peak loading of about 1200 MW against 1565MVA (~75% loading). Considering the load growth as indicated by PSTCL outage of one 500 MVA ICT at Moga, other ICTs may become 'N-1' non-compliant in future. In the 198th OCC meeting of NRPC held on 17.08.2022, NRLDC had also highlighted that the loading of 400/220kV ICT at Moga was close to N-1 limits.

POWERGRID vide mail 14.09.22 also confirmed the feasibility to replace the existing 250 MVA ICT at Moga with 500 MVA ICT. However, POWERGRID informed that 220kV CTs in 220kV ICT bay needs to be replaced due to low rating. Considering the unprecedented growth of load in Punjab & request of PSTCL, it was agreed to replace the 250 MVA ICT at 765/400/220kV Moga with a 500 MVA ICT (Figure 4-12)

Scope of work along with tentative Cost and Implementation time-frame

Sl. No.	Scope of the Transmission Scheme	Capacity/km	Implementation timeframe
1	Replacement of 1x250 MVA, 400/220 kV ICT to 500 MVA at 765/400/220 kV Moga (PG) S/s along with associated works at 220 kV level	500 MVA 400/220 kV ICT- 1no. (with associated works at 220 kV level)	18 months from the issue of OM
Total Estimated Cost:			INR 27.03 Crore

Note : TSP may expedite the implementation of the above transmission scheme to the extent possible, as per the request of PSTCL vide letter dated 06.09.22 for implementation schedule of May'23 (reconfirmed to 31.05.23 vide mail dated 01.11.22)

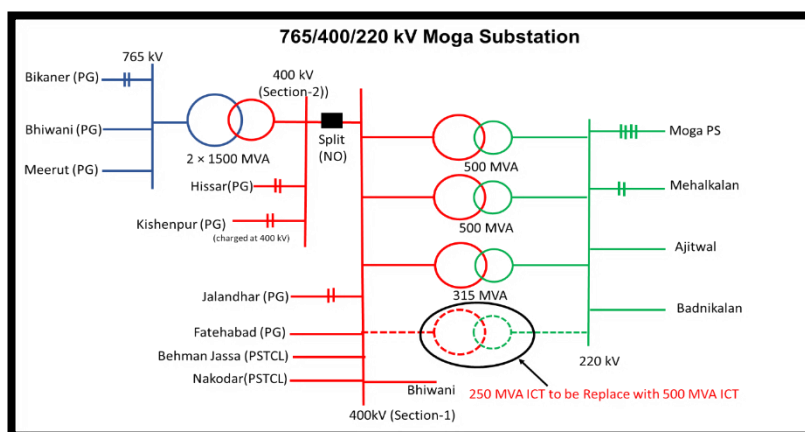

Figure 4-12: Schematic of 765/400/220kV Moga S/s

The scheme (A to D) is already approved in 11th CMETS-NR meeting held on 30.09.22. Further scheme approved in 9th meeting of CTU Committee on transmission projects (CCTP) for implementation.

4.4.4 Himachal Pradesh

(a) Transmission system for evacuation of power from Shongtong Karcham HEP (450MW) and Tidong HEP (150 MW)

In the 50th NRPC Meeting, Transmission system for evacuation of power from Kaza Solar Power Project (880 MW) was discussed and agreed. Subsequently, in the 54th NRPC Meeting held on 31.05.22, it was informed that three hydro-electric power stations (880 MW Jangi Thopan HEP of SJVN, 150 MW Tidong HEP of Statkraft, 450 MW Shongtong Karcham HEP of HPPCL) are getting connected to the same system near Wangtoo. Hence,

this network will be utilised both for solar and hydro. Jangi Thopan HEP schedule is Oct'29 as indicated by SJVN

During the CEA meeting held on 12/07/2022 to review the Master Plan for the Hydro Projects and Kaza Solar Power Project in Himachal Pradesh, it was deliberated that when the transmission system for evacuation of power from Kaza Solar Park was planned, it was proposed that power from Shongtong Karcham HEP may be evacuated through LILO of one circuit of the 400 kV Kaza–Wangtoo D/c Line at Shongtong Karcham HEP. HPPCL informed that as Shongtong Karcham HEP is expected to be commissioned by Nov'25, therefore, the implementation of the transmission system for evacuation of power from Shongtong Karcham HEP needs to be started at the earliest so that the same could be completed in matching timeframe.

Subsequently, based on discussions held in MOP meeting on 14.07.22, SJVNL vide email dated 19/08/2022 informed that the land involved in the park is a forest land which needs to be diverted and this additional financial implication for forest land diversion shall be huge and will make the Park unviable. SJVNL informed the revised commissioning schedule of Kaza Solar Park as Mar'26 (Unit-1) to Dec'26 (unit-7) (Progressively) and highlighted that some delay is anticipated in land acquisition activities of the project. Further, there is no St-II Connectivity/LTA application for Kaza Solar Park yet and commissioning schedule of Kaza generation had also been revised repeatedly by SJVNL.

During the 9th CMETS-NR meeting held on 28/07/2022, it was deliberated that in case the Kaza Solar Park is not materialized in near future, this high-capacity line shall be taken up from Wangtoo S/s to Jhangi PS via Shongtong HEP for implementation considering the progress of Shongtong & Tidong HEP. In the above meeting, Grant of Connectivity to M/s Tidong Power Generation Private Limited (150 MW) in ISTS was agreed at Jhangi PS as final connectivity system whereas for interim connectivity HPPTCL system through LILO of one circuit of existing Kashang – Bhaba 220 kV D/c will be utilised, till commissioning of Jangi Pooling Station as per HPERC order.

Subsequently, in the 10th CMETS-NR meeting held on 30.08.22, Connectivity & LTA of Shongtong Karcham (450 MW) and LTA of Tidong (75 MW) in ISTS was also reviewed. In the meeting, it was deliberated that in view of email of SJVN reg. Kaza Solar Park, upcoming Hydro projects (Shongtong & Tidong HEP) as well as considering ROW issues in that terrain, high-capacity line may be taken up from Wangtoo S/s to Jhangi PS via Shongtong HEP in first phase and this corridor shall be extended to Kaza Solar Park, in next phase, when commissioning schedule Kaza project is firmed up along with requisite applications.

In the meeting M/s Tidong had also informed that their project will be ready progressively from Mar'23 onwards which will utilise interim connectivity through HPPTCL system. Though ISTS Connectivity system for Tidong was agreed in 9th CMETS-NR meeting, however, as Shongtong HEP Connectivity/LTA system was to be taken up in 10th CMETS-NR meeting and had implication on Tidong system utilizing same corridor, it was decided to discuss the same again in above meeting. As informed by HPPCL in CEA meeting dated 12/07/22, Commissioning Schedule for Shongtong HEP (Nov'25) was ahead of transmission requirement for Tidong HEP (Jul'26).

Based on the above generation schedules, for connectivity of Tidong HEP, 400 kV Jhangi PS - Shongtong Karchham HEP (Quad) D/c line with bypassing arrangement of one circuit was proposed in 10th CMETS-NR meeting.

It was also mentioned that GRID INDIA had earlier got SPS implemented on hydro generations in above complex (about 3500 MW) due to machine oscillations. Subsequently additional transmission corridors (towards Kala Amb etc) have also come up in that complex, however SPS is retained. NRLDC opined that in peak hydro season, all hydro projects generate at 110% level and Karcham Wangtoo Installed Capacity is also revised (up) recently by CEA. Therefore, in order to avoid outage of large chunk of hydro generation, N-1-1 condition is also complied w.r.t SPS implementation to maintain system reliability. Therefore considering huge quantum of hydro generation in above complex after additional generation (600 MW), it may be prudent to plan additional corridor beyond Wangtoo to maintain system reliability & security.

CTU vide mail 19.09.22 informed that in the 10th CMETS-NR meeting, HPPCL was asked to confirm the revised start date of Connectivity & LTA for Shongtong HEP. It was deliberated that the transmission system (400kV Jhangi-Wangtoo-Panchkula D/c Corridor) is agreed however same shall be phased after HPPCL confirmation on the commissioning schedule of Shongtong HEP, if required. Subsequently, HPPCL vide their email dated 08/09/22 confirmed the commissioning schedule of Shongtong HEP as 31st July'2026. With this, Transmission requirement for Tidong HEP (01st Jul'26) [based on Kashang-II schedule] came ahead of Shongtong (31.07.26) which necessitated re-phasing of transmission system.

Considering above schedule of HEPs, system studies were reviewed. Based on the studies, it also appeared that existing corridor beyond Wangtoo is adequate for only Tidong LTA (75 MW). Accordingly, necessary phasing for transmission requirement was carried out for both the HEPs (Tidong & Shongtong) based on their respective schedules. Therefore, 400/220 kV Jhangi PS and 400 kV Jhangi-Wangtoo D/c corridor is decided to be taken up in first phase with Tidong HEP, whereas 400kV Wangtoo- Panchkula D/c line would be taken up in next phase with Shongtong HEP or other Hydro/Solar generation in that complex.

In view of above, Inter State Transmission system for Tidong HEP under Phase-I and for Shongtong HEP under Phase-2. The above Corridors shall be utilised for Hydro generation 1604 MW (Shongtong-450 MW; Tidong-150 MW & Jhangi Thopan -804 MW) as well as Kaza Solar Park (880 MW) after connectivity of Kaza PS with 400kV Jhangi PS. In this way, the identified corridors shall be utilised for 2284 MW envisaged RE generation including Hydro (Figure 4-13).

Scope of work along with tentative Cost and Implementation time-frame

Sl.	Scope of the Transmission Scheme	Capacity /km	Implementation timeframe
Phase-I with Tidong HEP:			
1.	Establishment of 2x315 MVA (7x105 MVA 1-ph units including a spare unit) 400/220 kV GIS Pooling Station at Jhangi	• 400/220 kV ICTs- 2x315 MVA (7x105 MVA 1-ph units including a spare unit)	01st July 2026

	<p>Future space provision for :</p> <ul style="list-style-type: none"> • 5 nos. of 400 kV line bays • 6 nos. of 220 kV line bays for future projects (space for 2 bays to be utilized for connectivity to Tidong generation) • 2 no. of 400/220 kV Transformer • 1 no. 420 kV Bus Reactor along with bay • 220 kV Sectionalization bay: 1 set • Bus Coupler: 1 no. 	<ul style="list-style-type: none"> • 400kV ICT bays- 2nos. • 220kV ICT bays- 2nos. • 400kV line bays (GIS) -2 nos. (for Jhangi PS – Wangtoo D/c line) • 420kV Reactor bay-1 no • 420 kV Bus reactor -1 nos (4x 41.66 MVA 1-ph units including a spare unit) 	
2	400 kV Jhangi PS – Wangtoo (Quad) D/c line (Line capacity shall be 2500 MVA per circuit at nominal voltage)	Line length-54 km	
3	400kV bays at Wangtoo for termination of 400 kV Jhangi PS – Wangtoo D/c line	400kV bays – 2nos.(GIS)	
Phase-II with Shongtong HEP			
1.	LILO of one circuit of Jhangi PS - Wangtoo (HPPTCL) 400 kV D/c (Quad) line [§] at generation switchyard of Shongtong HEP	LILO Line length- 1 km	31th July, 2026
2.	Wangtoo (HPPTCL) - Panchkula (PG) 400 kV D/c (Twin HTLS*) line along with 80 MVAr switchable line reactor at Panchkula end on each circuit	Line length-210km	
3	400kV bays at Wangtoo S/s (2 nos) and Panchkula S/s (2nos) for termination of 400 kV Wangtoo (HPPTCL) - Panchkula (PG) D/c line	400 kV Line bays- 4 nos. (2 nos. GIS bays at Wangtoo and 2 nos. AIS bays at Panchkula)	

[§] Line capacity shall be 2500 MVA per circuit at nominal voltage

* with minimum capacity of 2100 MVA on each circuit at nominal voltage

Note :

- (i) *Tidong HEP- Jhangi PS 220 kV D/C line (along with associated bays at both ends)- under the scope of applicant/generation developer.*
- (ii) Developer of Shongtong HEP to provide 2 nos. of 400kV bays at Shongtong switchyard for LILO of one circuit of Jhangi PS - Wangtoo (HPPTCL) 400 kV D/c (Quad) line at generation switchyard of Shongtong HEP



Figure 4-13: Tr. system for evacuation of power from Shongtong) and Tidong HEP

The scheme is agreed for implementation in 11th meeting of the "National Committee on Transmission" (NCT) was held on 28th December, 2022

4.4.5 Perspective transmission schemes under planning

Transmission system for evacuation of RE power from Rajasthan Ph-IV (75GW)

MNRE vide letter 15.02.22 informed that SECI has identified REZs of aggregate capacity of 181.5GW in eight states for achieving 500GW capacity from Non Fossile fuel (incl. RE) by 2030. These RE capacities include the Solar –Wind hybrid projects along with energy storage systems. In the meeting, it was decided that based on the above identified REZs, CEA & CTU will prepare the transmission plan.

Out of total capacity, planning is to be done for 75GW RE (60GW-Solar, 15GW-Wind) installed capacity in Rajasthan with evacuation requirement of 48GW from GIB (Jaisalmer, Jodhpur, Barmer) and Non GIB Zones Sanchore, Sirohi, Jalor, Pali, Ajmer, Bikaner, Nagaur).

As part of above comprehensive plan, a transmission scheme is already evolved for about 8GW (Solar) in Bikaner complex (14 GW potential along with 6 GW BESS) and 7.5 GW RE (Solar :7GW, Wind : 7GW, BESS : 3GW) in Fatehgarh-IV/Barmer complex in Rajasthan . transmission scheme for 2 GW (Solar :1GW, Wind : 2GW) at Ramgarh complex is under planning and taken up in next rolling plan

4.5 Measures taken for mitigation of the issues of Rolling Plan Report

4.5.1 Measures for controlling over-voltage

As per the voltage analysis carried out in Rolling Plan (Interim report) published for 2027-28 timeframe, 33 nos. of 765 kV (7 no.) and 400 kV (26 no.) buses were having issue of high voltage (voltage more than 1.05 pu)

For above, Comprehensive studies for high voltage and requirement of reactive compensation at the various substations in NR was deliberated in 8th CMETS-NR meeting and it was decided and agreed that scheme to control overvoltages may be segregated in two phases. In Phase-I, being an urgent requirement, line reactor proposal was agreed to be taken up for implementation. In Phase-II, Eleven nos. of bus reactors were proposed on ISTS/STU substations, however bus reactive compensation (Bus reactors) will be reviewed and taken up in next rolling plan.

4.5.2 Measures for controlling short circuit

As per the short circuit analysis carried out in Rolling Plan (Interim report) published for 2027-28 timeframe, Short circuit level was calculated for all 765kV and 400 kV buses of Northern Region and it was noted that 5 nos. of ISTS substations and 11 nos. of STU/Generator substations exceeding fault level more than 20% design fault level for which immediate action shall be required.

Studies to limit high short circuit on ISTS S/s will be carried out and taken up in Joint study meeting in phases. STUs/Gen developer are also required to take necessary actions such as bus splitting, bypassing of lines, fault limiting reactors etc to resolve the issue of high fault level at their buses.

4.5.3 Measures for controlling loading of transformers and Transmission lines

As per the analysis carried out in Rolling Plan (Interim report) published for 2027-28, transformers at 3 nos. of 765/400 kV substations and 12 nos. of 400/220kV substations were having critical loading. Transformer loading on ISTS substations at Orai, Allahabad and Agra substation is higher at few instances in 2027-28 timeframe. Augmentation/Replacement of ICT may be required w.r.t future load growth of UP and real time operational data. High loading at Bhiwani ICT observed in Solar max scenario. Augmentation/Replacement of ICT may be required in future with development of solar generation in Rajasthan and Haryana load. STU may take necessary action for ICTs at STU S/s by load diversion or augmentations.

In the analysis carried out in Rolling Plan 2027-28 (Interim report), 12 nos. of 400 kV lines are observed to be having critical loading in base case as well as Contingency scenario. To relieve overloading of 400 kV Bareilly(765) - Bareilly(PG) and 400 kV Bareilly(PG) - Bareilly(UP), strengthening already identified.

Loading of 400kV Bhiwani(PG)-Bhiwani(BBMB) line and 400kV Bhiwani(PG)-Jind (PG D/c line shall be suitably addressed with developed of GHAVP generation and Haryana load. PTCUL has already identified 400kv strengthening scheme under intra state for diversion of load from Roorkee which may relieve loading of 400kV Roorkee-Rishikesh line.

RVPN also planned a comprehensive transmission scheme for RE projects envisaged at intra state level. The scheme is under approval. The proposed intra state scheme would relieve the loading of 400kV Jaisamer-2 -Barmer D/c line and 400kV Merta – Jodhpur (Kankani) line . For balance transmission lines in other states (ISTS/STUs), suitable strengthening scheme will be indentified in next rolling plan.

4.6 System Study Analysis and Results for 2027-28 Timeframe

Based on the load-generation scenarios as elaborated in section 4.3, various system studies have been carried out in PSSE. Planned/ Under implementation Transmission system that are expected to be commissioned in 2027-28 timeframe are considered for conducting these studies.

Renewable Energy Zones (REZs) were identified by MNRE/SECI with a total capacity of 181.5 GW for likely benefits by the year 2030 in eight states, which includes 75 GW REZ potential in Rajasthan comprising of 15 GW Wind and 60 GW Solar. In this regard a Committee on Transmission Planning for RE was constituted by MOP for planning of the requisite Inter State Transmission System required for the targeted RE capacity by 2030.

As part of committee report “Transmission system for integration of over 500GW capacity by 2030” as well as MNRE/SECI inputs, a Comprehensive transmission plan for evacuation of 75GW RE potential from Rajasthan is evolved. In the report, implementation of transmission system has been phased out in 3 parts; Phase-I by March 2025, Phase-II by December 2027 and Phase-III by December 2030. Therefore, prioritized phase-I & phase-II potential and associated transmission system has also been considered in the PSSE files prepared for Rolling Plan of 2027-28 timeframe.

System studies have been conducted on these files prepared for 9 scenarios. Results of these studies were analysed and the same are deliberated in subsequent sections-

4.6.1 Voltage Analysis

Voltages of all 765 kV and 400 kV buses were observed in all the nine scenarios. Maximum and minimum voltage of each bus were identified from the bus voltages in the nine number of scenarios. From the simulation results, no issue of undervoltage it was observed in Northern Region.

However, 765kV & 400kV buses were observed to be having voltage more than 1.05 pu is depicted in **Table 4-6:**

Table 4-6: Substations having high voltage in NR

Sl. No.	Bus Name	Voltage Level (kV)	Owner	Max(pu)	Scenario
1	Jodhpur Kankani	765	STU	1.06	2,8
2	Jaipur	765	ISTS	1.05	2
3	Chamera-1	400	ISTS	1.07	8,9
4	Hamirpur	400	ISTS	1.07	8,9
5	Dhanasanu	400	STU	1.09	7,9
6	Behmnjsingh (Malkana)	400	STU	1.1	7,9
7	Talwandi Saboo	400	STU	1.09	7,9

Sl. No.	Bus Name	Voltage Level (kV)	Owner	Max(pu)	Scenario
8	Dhuri	400	STU	1.09	7,9
9	Makhu	400	STU	1.09	7,9
10	Mukatasar	400	STU	1.1	7,8,9
11	Nakodar	400	STU	1.08	7,9
12	Amritsar	400	ISTS	1.1	7,8,9
13	Moga (split section)	400	ISTS	1.06	7,8,9
14	Jallandar	400	ISTS	1.08	7,9
15	Hindaun	400	STU	1.07	9
16	Deedwana	400	STU	1.06	9
17	Ajmer	400	STU	1.08	9
18	Jodhpur (Kankani)	400	STU	1.06	2

Due to no solar generation in evening/night time, there is minimal power flow on 765kV long lines impacting high voltages in NR. However adequate bus reactive compensation is also provided in this regard. Some of substations i.e. Talwandi Saboo, Makhu, Mukatasar, Nakodar, Dhuri, Dhanasanu, Amritsar, Jallandar having high voltage in off peak scenarios and in winter season due to low demand in NR.

Comprehensive studies for high voltage and requirement of reactive compensation at the various substations in NR was deliberated in 8th CMETS-NR meeting and it was decided and agreed that scheme to control overvoltages may be segregated in two phases. In Phase-I, being an urgent requirement, line reactor proposal was agreed and under implementation.

In Phase-II, bus reactive compensation will be reviewed based on study file after incorporating GRID INDIA and STUs observations and taken up in next rolling plan.

4.6.2 Short Circuit Analysis

Short circuit level was calculated for all 765kV and 400 kV buses of Northern Region and buses having fault level more than the design rating under any scenario were identified. From analysis it is emerged that there are 74 nos. of substations (765kV-4 nos., 400kV- 70 nos)in NR having fault level more than designed capacity

Out of above,10 nos. of ISTS substations and 14 nos. of STU/Generator substations exceeding fault level more than 20% design fault level for which immediate action shall be required. Details of the substations under any scenario are tabulated below in **Table 4-7 & Table 4-8:**

ISTS Substations

Table 4-7: ISTS Buses Exceeding Designed Fault Level (1.2pu) in NR

Sl. No.	Substation Name	Scenario No.	Highest Fault level (kA)	Design Rating (kA)
1	400kV Meerut	All	66	40
2	400kV Neemrana	All	56	40
3	400kV Lucknow	All	54	40

Sl. No.	Substation Name	Scenario No.	Highest Fault level (kA)	Design Rating (kA)
4	400kV Abdullapur	Most	52	40
5	400kV Lucknow (765/400kV)	Most	52	40
6	400kV Bassi	Most	52	40
7	400kV Bhiwadi	Most	52	40
8	400kV Ballabgarh	Most	50	40
9	400kV Allahabad	Most	51	40
10	400kV Patiala	Most	48	40

STU/Generation Substations

Table 4-8: STU Buses Exceeding Designed Fault Level (1.2pu) in NR

Sl. No.	Substation Name	Owner State	Scenario No.	Highest Fault level (kA)	Design Rating(kA)
1	400kV Greater Noida	UP	All	60	40
2	400kV Greater Noida	UP	All	59	40
3	400kV Dhanonda	Haryana	All	58	40
4	400kV Dadri	Gen	All	60	40
5	400kV Dadri (HVDC)	Gen	All	59	40
6	400kv Agra	UP	All	57	40
7	400kV Bawana	Delhi	All	54	40
8	400kV Jaipur (Phagi)	Rajasthan	All	54	40
9	400kV Anpara	Gen	Most	53	40
10	400kV Bawana Gas	Delhi	Most	52	40
11	400kV Daultabad	Haryana	Most	52	40
12	400kV Jhahjar	Gen	Most	52	48
13	400kV Anpara C	Gen	Most	52	40
14	400kV Meja	UP	Most	49	40

Studies to limit high short circuit on ISTS S/s will be carried out and taken up in next rolling plan. STUs/Generation developer are also required to take necessary actions such as bus splitting, bypassing of lines, fault limiting reactors etc to resolve the issue of high fault level at their substations.

4.6.3 Contingency Analysis

a) Transmission Lines

In the base case file prepared for 2027-28 timeframe, in NR, 11 nos. of 400 kV lines are observed to be having critical loading in base case as well as Contingency scenario. Details of such lines are as under (**Table 4-9**):

Table 4-9: Major transmission lines having critical loading in NR

Sl. No.	Name of the Line	Scenario No.	Case	Owner	Max Loading	Rating	Remark
1	Baglihar – New Wanpoh 400kV line	1,4, 5,7	Base case (SC-4,7), Contingency (Sc 1,4,5,7)	ISTS	1159 MW (1530 MW under n-1)	857 (Twin Moose)	The line loading will be higher in simultaneous solar and high hydro scenario. Loading will be relieved with upcoming UMREPP in Kargil area
2	Anpara - Singraulli 400kV line	9	Base case/Contingency	ISTS	1000 (1005 MW under n-1)	857 (Twin Moose)	The line loading will be higher at some instances. Monitoring required
3	400kV Merta - Jodhpur(Kan kani) line	1,4	Contingency	STU	897(under n-1)	857 (Twin Moose)	The line loading is marginally higher in Solar max scenario. With new proposed RVPN schemes loading may be relieved.
4	400kV Meja-Allahabad D/c line	2,3,5, 6.7.8	Contingency	ISTS	1195 (under n-1)	857 (Twin Moose)	The line loading is higher in evening peak and night off peak scenario. Action may be required.
5	400kV Agra-Agra(UP) line	1,2,3,5,6	Base case/Contingency	ISTS	1280 (under n-1:1600 MW)	857 (Twin Moose)	The line loading is critical in evening peak and night off peak scenario. Action required.
6	400kV Agra-Agra(Fatehabad) line	2,3,5	Contingency	ISTS	1161 (under n-1)	857 (Twin Moose)	The line loading is higher in evening peak and night off peak scenario. Action may be required.
7	400kV Lucknow (PG) - Lucknow	1,4,7	Contingency	ISTS	2200 (under n-1)	1714	The line loading is marginally higher in

Sl. No.	Name of the Line	Scenario No.	Case	Owner	Max Loading	Rating	Remark
	(765) D/c line						noon scenario. Monitoring required
8	400kV Bhiwani(PG)-Bhiwani(BB MB) line	1,4	Contingency	ISTS	1031 (1142 (under N-1))	857	The line loading is higher in solar max scenario . Monitoring required
9	400kV Bhiwani(PG)-Jind (PG D/c line	2,5	Contingency	ISTS	1170 (under N-1)	857	The line loading is marginally higher in Solar Max scenario. Monitoring required
10	400 kV Bareilly(PG) - Bareilly(UP)	1	Contingency	ISTS	900 (under N-1)	857	The line loading is marginally higher at some instances. Monitoring required
11	400 kV Balia (PG) - Mau	6	Contingency	ISTS	915 (under N-1)	857	The line loading is marginally higher at some instances. Monitoring required

Additional system strengthening may be planned by respective STU's to feed the growing demand and increase in drawal from ISTS.

b) Transformers

In the base case file prepared for 2027-28 timeframe, transformers at 3 nos. of 765/400 kV substations and 18 nos. of 400/220kV substations are having critical loading. Details of transformers is as under (**Table 4-10**)

Table 4-10: Major transformers having critical loading in NR

Sl. No.	Name of the Element	Scenario No.	Owner	Case	Maximum Loading/ICT	Remark
1	765/400kV, 2x1000 +1x1500 MVA Bhiwani ICTs	1,4	ISTS	N-1 Contingency	1295 (on 1000MVA ICT)	High loading observed in Solar max scenario. Augmentation/Replacement of ICT may be required. 1X1500MVA ICT agreed with Pang SP scheme
2	765/400kV, 2x1000 MVA Orai ICTs	2,5	ISTS	N-1 Contingency	1077	loading is higher in future due to load growth of UP. Augmentation/Replacement of ICT may be required

Sl. No.	Name of the Element	Scenario No.	Owner	Case	Maximum Loading/ICT	Remark
3	765/400kV, 2X1500 MVA Varanasi ICTs	1,4	ISTS	N-1 Contingency	1761	loading is marginally higher at few instances. Augmentation/Replacement of ICT may be required with development of Bhadla-III-Fatehpur HVDC scheme
4	400/220kV, 3X315 MVA Kishenpur ICTs	1,2,4,5,7	ISTS	Base Case	520	High Loading observed with upcoming HEPs integrated at Kishtiwari/Kishenpur. Augmentation of ICT shall be required
5	400/220kV, 2X315 MVA Hindaun ICTs	Most	STU	N-1 Contingency	376	High loading observed in most of scenarios. Load diversion/Augmentation of ICT shall be required
6	400/220kV, 2X315+1x240 MVA Obra 2 ICTs	2,5,8	STU	N-1 Contingency	340 (on 315MVA ICT)	loading is marginally higher at low/no generation of Obra thermal plant. Augmentation/Replacement of ICT may be required
7	400/220kV, 3X315 MVA Allahabad ICTs	2,5	ISTS	N-1 Contingency	352	loading is marginally higher at few instances. Augmentation/Replacement of ICT may be required based on actual load growth and operational feedback
8	400/220kV, 2X315 MVA Agra ICTs	2,3,5,6	ISTS	N-1 Contingency	352	loading is higher in future due to load growth of UP. Augmentation/Replacement of ICT may be required based on actual load growth and operational feedback
9	400/220 kV 2x500 MVA Ropar S/s	5	STU	N-1 Contingency	521	loading is higher in future due to load growth of Rajasthan. Augmentation/ Replacement of ICT may be required based on actual load growth and operational feedback
10	400/220 kV 2x315 MVA Merta S/s	6	STU	N-1 Contingency	311	loading is higher in future due to load growth of Rajasthan. Augmentation/ Replacement of ICT may be required based on actual load growth and operational feedback

Sl. No.	Name of the Element	Scenario No.	Owner	Case	Maximum Loading/ICT	Remark
11	400/220 kV 2x315 MVA Ajmer S/s	5,6	STU	N-1 Contingency	352(on 315 MVA ICT)	loading is higher in future due to load growth of Rajasthan. Augmentation/ Replacement of ICT may be required in future based on actual load growth and operational feedback
12	400/220 kV 3x315 MVA Chittorgarh S/s	1,4,6	STU	N-1 Contingency	396	loading is higher in future due to load growth of Rajasthan. Augmentation/ Replacement of ICT may be required based on actual load growth and operational feedback
13	400/220 kV 2x315 MVA Kota S/s	1,4,7	ISTS	N-1 Contingency	433	loading is higher in future due to load growth of Rajasthan. Augmentation/ Replacement of ICT may be required based on actual load growth and operational feedback
14	400/220kV, 2X315 MVA Kanpur ICTs	1,4	ISTS	N-1 Contingency	395	loading is marginally higher at few instances. Augmentation/Replacement of ICT may be required based on actual load growth and operational feedback
15	400/220kV, 2X500 MVA Aligarh ICTs	2,4,5	ISTS	N-1 Contingency	500	loading is marginally higher at few instances. Augmentation of ICT may be required based on actual load growth and operational feedback
16	400/220kV, 3X315 MVA Nallagarh ICTs	1,2,4,5	ISTS	N-1 Contingency	291 (on 315MVA ICT)	loading is marginally higher at few instances. Augmentation/Replacement of ICT shall be taken up in next rolling plan
17	400/220kV, 3X500 MVA Patran ICTs	1,4	ISTS	N-1 Contingency	539 (on 500MVA ICT)	loading is marginally higher at few instances. Augmentation of ICT may be required in future based on actual load growth and operational feedback

Sl. No.	Name of the Element	Scenario No.	Owner	Case	Maximum Loading/ICT	Remark
18	400/220kV, 3X250+1x315 MVA Heerapura ICTs	1,2,4,5,7	STU	N-1 Contingency	271 (on 250MVA ICT)	loading is marginally higher in most instances. Augmentation/Replacement of ICT may be required in future based on actual load growth and operational feedback
19	400/220kV, 2x500 MVA Dwarka ICTs	1,2,4,5	ISTS	N-1 Contingency	523	loading is marginally higher in most instances. Augmentation of ICT may be required in future based on actual load growth and operational feedback
20	400/220kV, 2X315 MVA Deedwana ICTs	1,2,4	STU	N-1 Contingency	392	loading is marginally higher at few instances. Augmentation/Replacement of ICT may be required based on actual load growth and operational feedback
21	400/220kV, 2x315+1x500 MVA Bassi ICTs	1,2,4,5	ISTS	N-1 Contingency	344 (on 315MVA)	loading is marginally higher in most instances. Augmentation of ICT may be required in future based on actual load growth and operational feedback

Respective STUs/Owners are required to take advance action to mitigate this issue. Additional system strengthening in these areas such as planning additional feeds from ISTS, shifting of loads, ICT augmentation, increase in self generation, etc. may be required to feed the growing demand.

Chapter 5: Western Region

Due to geographical location, Western Region is connected to Northern, Southern and Eastern Regions through 765kV/400kV high capacity corridors along with Back to Back HVDCs and Bi-Pole HVDC links. The thermal generating stations of Western Regions are predominantly concentrated in the coal rich states of Chhattisgarh, Eastern part of Maharashtra and Madhya Pradesh. Further, Gujarat, Maharashtra and Madhya Pradesh are RE rich states comprising of Solar & Wind capacity. Western part of Maharashtra, southern Gujarat and DD & DNH have high demand and less internal generation. Accordingly, power flows from Chhattisgarh/ Eastern Maharashtra through high capacity corridors to Western part of Maharashtra, Southern Gujarat, DD & DNH. Based on the generation availability and demand, Western Region imports power from other regions during high RE scenarios whereas it exports power to other regions during evening peak and night off peak load.

5.1 Power Supply Scenario as on Feb'23

As on Feb'2023, total Installed Capacity (IC) of Western Region was about 134 GW and the peak demand was about 72 GW. At present, there is no shortage of power supply in meeting these demands. State-wise breakup is summarised at **Table 5-1**.

Table 5-1: All India Installed Capacity and Demand met as on Feb'23

(All Fig in GW)

State	Generation								Peak Demand
	Fossil			Non-Fossil				Grand Total	
	Thermal	Gas	Total	Nuclear	Hydro	RES (MNRE)	Total		
Gujarat	18.6	6.6	25.1	0.6	0.8	19.0	20.3	45.5	21.5
MP	16.1	0.3	16.4	0.3	3.2	5.9	9.4	25.8	17.3
Maharashtra	25.3	3.5	28.8	0.7	3.3	11.8	15.8	44.6	30.9
Chhattisgarh	12.2	0.0	12.2	0.0	0.2	1.3	1.6	13.8	5.3
DD	0.2	0.0	0.2	0.0	0.0	0.0	0.0	0.3	0.4
DNH	0.4	0.1	0.5	0.0	0.0	0.0	0.0	0.5	0.9
Goa	0.5	0.1	0.6	0.0	0.0	0.0	0.1	0.6	0.7
Central unallocated	2.8	0.2	3.0	0.2	0.0	0.0	0.2	3.2	
WR	76.0	10.8	86.8	1.8	7.6	38.1	47.5	134.3	71.7

Source: CEA Monthly Report

5.2 Envisaged Power Supply Scenario by 2027-28

As per the 20th EPS, Western Region demand for 2027-28 timeframe is expected to increase to about 95 GW. The Installed capacity of Western Region is expected to be about 203GW. The state wise bifurcation of the same is given at **Table 5-2**.

Table 5-2: Western Region Installed Capacity and Peak Demand (2027-28)

(All Fig in GW)

State	Generation									Peak Demand
	Fossil			Non-Fossil				ESS	Grand Total	
	Thermal	Gas	Total	Nuclear	Hydro	RES (MNRE)	Total			
Gujarat	7.8	2.8	10.6	0.0	0.3	15.9	16.2	0.2	27.0	29.6
MP	5.3	0.0	5.3	0.0	3.1	3.9	7.0	0.0	12.3	22.8
Maharashtra	19.5	1.2	20.7	0.0	2.5	9.5	12.1	0.4	33.2	38.1
Chhattisgarh	1.6	0.0	1.6	0.0	0.1	0.2	0.4	0.0	1.9	7.6
DD	0.0	0.0	0.0	0.0	0.0	0.0	0.0	0.0	0.0	0.5
DNH	0.0	0.0	0.0	0.0	0.0	0.0	0.0	0.0	0.0	1.3
Goa	0.0	0.0	0.0	0.0	0.0	0.0	0.0	0.0	0.0	0.9
Central	19.0	3.3	22.3	3.2	0.2	61.5	65.0	2.7	89.9	
IPP	35.6	2.8	38.4	0.0	0.0	0.0	0.0	0.0	38.4	
WR	88.8	10.1	98.9	3.2	6.3	91	100.6	3.3	202.8	94.7

There is growth of around 32% in the peak demand of Western Region from present timeframe to 2027-28. The state wise growth in demand for 2027-28 from present time-frame is tabulated below at **Table 5-3**:

Table 5-3: State-wise Demand Growth in Western Region

(All Fig in MW)

Peak Demand				
State	Present	20th EPS	Increase in demand	CAGR
	2022-23	2027-28		
Gujarat	21464	29573	8109	6.6%
MP	17347	22826	5479	5.6%
Maharashtra	30935	38105	7170	4.3%
Chhattisgarh	5339	7602	2263	7.3%
UT of DD & DNH	1278	1867	589	7.9%
Goa	718	945	227	5.6%
WR	71667	94748	23081	5.7%

From the above data it is observed that the CAGR growth of peak demand is maximum for UT of DD & DNH (7.9%) and minimum for Maharashtra (4.3%).

5.3 Load Generation Balance for 2027-28 timeframe

In Chapter-3, All India Load Generation Balance (LGB) for identified nine scenarios was prepared as per the methodology finalized in consultation with CTU, CEA and GRID INDIA. This section elaborates the Western Region Load Generation Balance (LGB) for 2027-28 timeframe. For Western Region also, three points on the daily load curve i.e. Solar max (afternoon), Peak load (evening) and Off-peak load (night) for three seasons viz. Monsoon (August), Summer (June) and Winter (February) have been considered.

Load generation balance has been prepared considering the generation despatch factors as mentioned at **Table 5-4** for the 9 scenarios. Further, thermal generators have been despatched as per the merit order.

Table 5-4: Western Region Generation Dispatch and Demand Factors

Scenario No & Name	Generation Dispatch Factors						Demand Factors
	Hydro	Nuclear	Solar	Wind	ESS	Gas	
1-Aug Solar Max	40%	80%	80%	55%	-100%	0%	88%
2-Aug Peak Load	70%	80%	0%	75%	60%	50%	84%
3-Aug Night Off Peak	40%	80%	0%	65%	40%	50%	57%
4-Jun Solar Max	40%	80%	85%	55%	-100%	0%	77%
5-Jun Peak Load	70%	80%	0%	75%	50%	50%	75%
6-Jun Night Off Peak	40%	80%	0%	65%	0%	50%	70%
7-Feb Solar Max	20%	80%	90%	10%	-100%	0%	94%
8-Feb Peak Load	40%	80%	0%	20%	60%	50%	86%
9-Feb Night Off Peak	20%	80%	0%	20%	40%	30%	61%

The despatch from thermal generations have been done considering merit order despatch. Based on the LGB, import / export of WR and the inter-regional flows through various corridors is summarised in **Table 5-5**. Further, both maximum and minimum is also highlighted in table below.

Table 5-5: Drawl of various states from ISTS grid

All Fig in MW)

IR Flows	Import / Export of Western Region								
	Aug'27 Time Frame			Jun'27 Time Frame			Feb'28 Time Frame		
Scenario No	1 (Solar Max)	2 (Peak Load)	3 (Off Peak)	4 (Solar Max)	5 (Peak Load)	6 (Off Peak)	7 (Solar Max)	8 (Peak Load)	9 (Off Peak)
WR-NR	-3740	15543	10062	2282	19972	-2874	-12357	1398	825
ER-WR	-9643	-6221	-6607	-11858	-6990	-5460	-10085	-1791	-3228
WR-SR	-13572	-15937	-11765	-13191	-16610	-10287	-6837	27	4854
Western Region	-7669	5826	4904	948	10352	-7700	-9108	3216	8906

Out of these nine scenarios, Scenario-7 and Scenario-5 corresponds to two extreme cases with import / export requirement of Western Region i.e. Maximum import (9.1 GW) and maximum export (10.3 GW) scenarios respectively. In all other scenarios, the import / export of Western Region varies between these two extremes.

Considering the above LGB for nine scenarios, load flow cases were prepared for 2027-28 timeframe. Detailed system studies have been carried out on the finalized load flow cases. The study results are discussed in subsequent sections.

5.4 ISTS Network schemes evolved from Mar'22 to Feb'23

Various transmission systems have been planned for implementation in the Consultative Meeting for Evolution of Transmission System of WR (CMETS-WR) and joint study meetings from Mar'22 to Feb'23. These schemes have either been approved or under various stages of approval. The details of the schemes have been summarized below at **Table 5-6:**

Table 5-6: Details of the schemes evolved in WR

Sr. No.	Name of Scheme	Time frame	Tentative cost (in Crores)
Chhattisgarh			
1.	Augmentation of Transformation Capacity by 1x500 MVA, 400/220kV ICT (3rd) at Raigarh (PG) S/s	2023-24	45.52
2.	Western Region Expansion Scheme-XXIV	2023-24	10.2
3.	Western Region Expansion Scheme-XXX	2023-24	26.64
Maharashtra			
1.	Western Region Expansion Scheme XXXI (WRES-XXXI): Part A	Scheme shall be further deliberated among stakeholders	
2.	Western Region Expansion Scheme XXXI (WRES-XXXI): Part B	Scheme shall be further deliberated among stakeholders	
3.	Western Region Expansion Scheme XXXI (WRES-XXXI): Part C	2024-25	86
4.	Augmentation of transformation capacity at Kallam PS by 2x500MVA, 400/220kV ICTs (3rd & 4th) along with 220kV bays for RE interconnection	2024-25	157
5.	400 kV line bay at Solapur PS for St-II connectivity for Renew Green Energy Solutions Private Limited	2023-24	10
6.	Transmission system for evacuation of 2GW RE from Dhule, Maharashtra	2025-26	637
7.	Transmission system for evacuation of power from RE projects in Solapur (1500MW) SEZ in Maharashtra	2025-26	471
Gujarat			
1.	Implementation of 1 no. 220kV line bay at Bhuj PS for providing Connectivity to M/s NTPC Renewable Energy Ltd. (300MW):	2023-24	5.84

2.	Transmission system for evacuation of additional 7 GW RE power from Khavda RE park under Phase-III	2025-26	7420
3.	Transmission System for Evacuation of Power from potential renewable energy zone in Khavda area of Gujarat under Phase-IV (7GW)	2025-26	12337
4.	Transmission System for Evacuation of Power from potential renewable energy zone in Khavda area of Gujarat under Phase-V (8GW)	2026-27	23334
5.	Provision of Dynamic Reactive Compensation at KPS1, KPS3 & Navsari(New) Substations	2025-26	681
6.	Scheme for drawal of 4000 MW power by MPSEZ UTILITIES LIMITED	2025-26	2200
7.	Transmission scheme for injection beyond 3 GW RE power at Khavda PS2 (KPS2)	2024-25	352
Madhya Pradesh			
1.	Western Region Expansion Scheme XXXIII (WRES-XXXIII): Part A	2024-25	126.09
2.	Western Region Expansion Scheme XXXIII (WRES-XXXIII): Part B	2025-26	1181
3.	Western Region Expansion Scheme XXXIII (WRES-XXXIII): Part B1	2025-26	19
4.	Western Region Expansion Scheme XXXIII (WRES-XXXIII): Part C	2025-26	556
5.	Western Region Expansion Scheme XXXIII (WRES-XXXIII): Part C1	2025-26	0.5
6.	Western Region Expansion Scheme XXXIII (WRES-XXXIII): Part D	2024-25	77.52
7.	Transmission scheme for evacuation of power from Neemuch 2GW WEZ	2025-26	667
8.	Transmission System for Evacuation of Power from RE Projects in Rajgarh 1000 MW SEZ in Madhya Pradesh - Phase-II	2025-26	540
9.	Transmission System for providing connectivity to M/s VEH Jayin Renewables Pvt. Ltd. at Rajgarh (PG) S/s	2024-25	29.33

5.4.1 Chhattisgarh

a. Augmentation of Transformation Capacity by 1x500 MVA, 400/220kV ICT (3rd) at Raigarh (PG) S/s

The scheme involves augmentation of transformation capacity at Raigarh(PG) S/s by 1x 500 MVA, 400/220kV ICT to resolve the overloading issues at Raigarh(PG) 400/220kV ICTs in present time frame as well as in future till further network augmentation in form of Pithora 400/220kV S/s is implemented by CSPTCL. Studies were carried out for 2023-24 Time frame without closing JPL – Raigarh & JPL – Gerwani 220kV lines and without considering Pithora 400/220kV S/s and loading on Raigarh 2x315MVA, 400/220kV ICTs was seen to be N-1 non-compliant (~400MW on one ICT after considering Raigarh – Malda 220kV D/c line in Mar'24).

The proposal was discussed in 8th CMETS-WR meeting held on 30.06.2022 wherein it was acknowledged that in the absence of Pithora 400/220kV S/s (planned after Mar'26), the overloading issues at Raigarh 400/220kV ICTs shall persist as can be seen from study results and the 3rd ICT was agreed accordingly.

Detailed scope of the scheme is as mentioned below:

Scope of work along with tentative Cost and Implementation time-frame:

Sl. No.	Scope of the Transmission Scheme	Capacity /km	Implementation timeframe
1.	Augmentation of 1x500 MVA, 400/220 kV ICT (3rd) at Raigarh(PG) S/s along with associated ICT bays	500MVA, 400/220kV ICT: 1 no. 400kV ICT bays: 1 no. 220kV ICT bays: 1 no.	15 months from the issue of OM by CTUIL
Total Estimated Cost			45.52 Cr. (approx.)

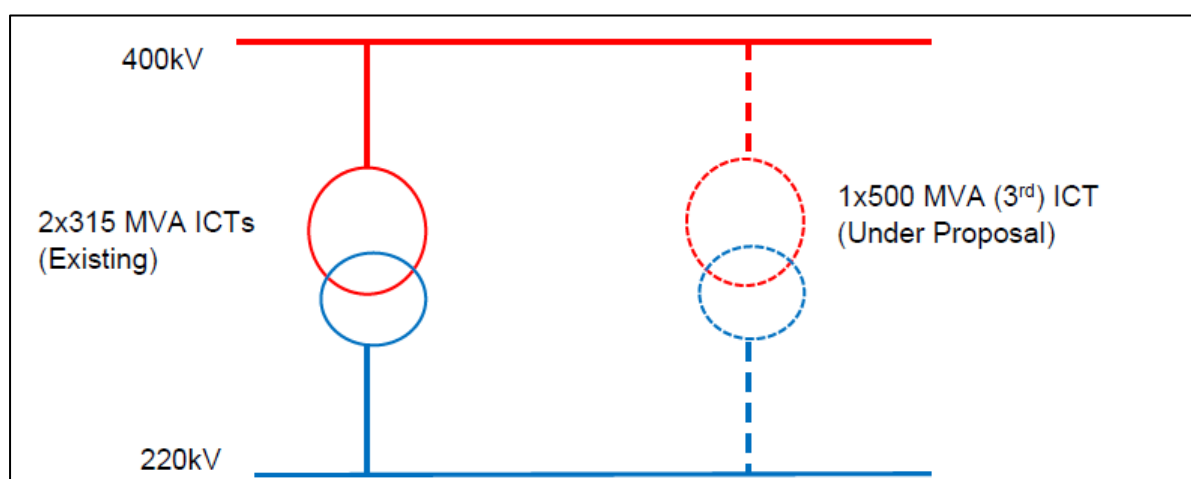

Figure 5-1: Augmentation of 1x500 MVA, 400/220kV ICT (3rd) at Raigarh (PG) S/s

The scheme was allotted to POWERGRID vide CTU OM dated 25.08.2022 with implementation timeframe as given above.

b. Western Region Expansion Scheme-XXIV (WRES-XXIV)

The scheme involves Conversion of 2x240MVAR Non-switchable line reactors at Raipur PS (associated with Raipur PS – Champa PS 765kV circuits 1 & 2) into Switchable line reactors along with NGR bypass arrangement. The scheme shall facilitate flexibility in system operation so that the 2x240MVAR line reactors at Raipur PS (associated with Raipur PS – Champa PS 765kV circuits 1 & 2) may be utilized as bus reactors for voltage control at Raipur PS after line opening.

The scheme was discussed and agreed in 3rd Consultation Meeting for Evolving Transmission Schemes in Western Region (CMETS-WR) held on 31.01.2022. The utilization of each 240MVA_r line reactor as a bus reactor at Raipur Pool (after line opening) leads to a drop in voltage to the tune of 2.2kV at Raipur PS (Durg). Detailed scope of the scheme is as mentioned below:

Sl. No.	Scope of the Transmission Scheme	Capacity/km	Implementation timeframe
1.	Conversion of 2x240MVA _r non-switchable line reactors at Raipur PS (associated with Raipur PS – Champa PS 765kV circuits 1 & 2) into Switchable line reactors along with NGR bypass arrangement	Switching equipment along with NGR bypass arrangement – 2 nos.	Jun'23
Total Estimated Cost:			INR 10.2 Crore

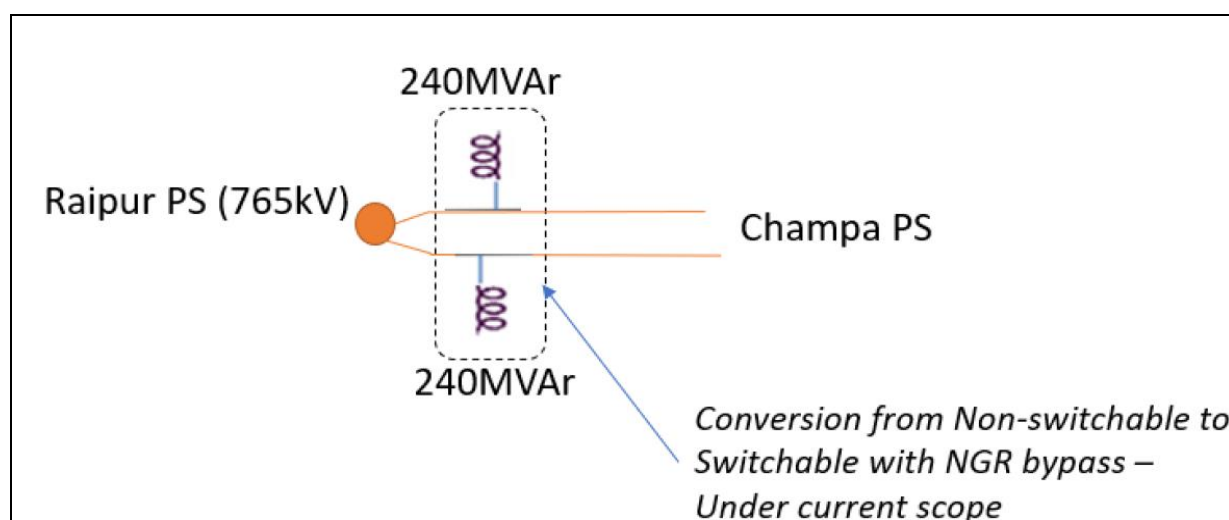

Figure 5-2: Western Region Expansion Scheme-XXIV (WRES-XXIV)

The scheme was allotted to POWERGRID vide CTU OM dated 24.06.2022 with implementation timeframe of Jun'23.

5.4.2 Maharashtra

a. Western Region Expansion Scheme-XXX (WRES-XXX)

The scheme involves Bypassing of Parli(PG) – Parli(M) 400kV D/c line (~5km.) and Parli(PG) – Parli(New) 400kV D/c (quad) line (~18km.) at Parli(PG) S/s at outskirts of the Parli(PG) S/s so as to form Parli(M) – Parli(New) 400kV D/c direct line. The scheme has been evolved to resolve the issue of overloading of Parli (M) - Parli (PG) 400 kV D/c line & control high fault level at Parli(PG) / Parli(M) 400kV buses. Studies were carried out in Scenario-7 (Feb Solar Max) & Scenario-8 (Feb Peak Load) 2026-27 time-frame and overloading was observed on Parli(PG) – Parli(M) 400kV D/c line (N-1 non compliant) and the fault levels at Parli(PG) and Parli(M) S/s were observed to be beyond design limit of 40kA.

The Short circuit levels observed before and after proposed scheme are tabulated below:

	3 phase fault level before bypassing (kA)	3 phase fault level after bypassing (kA)
Scenario-8		
Parli(M)	43	31
Parli(PG)	45	25
Scenario-7		
Parli(M)	35	30
Parli(PG)	36	24

Further, the loading on Parli (M) - Parli (PG) 400 kV D/c remains about 2x743MW in Scenario 7 case and the line remains N-1 non compliant. Hence, reconductoring of the line twin HTLS conductor has also been proposed as part of the scheme.

The scheme was deliberated in the 8th CMETS meeting of WR held on 30.06.2022. Detailed scope of the scheme is as mentioned below:

Scope of work along with tentative Cost and Implementation time-frame:

Sl. No.	Scope of the Transmission Scheme	Capacity /km	Implementation timeframe
1.	Bypassing of Parli(PG) – Parli(M) 400kV D/c line (~5km.) and Parli(PG) – Parli(New) 400kV D/c (quad) line (~18km.) at Parli(PG) S/s at outskirts of the Parli(PG) S/s so as to form Parli(M) – Parli(New) 400kV D/c direct line (refer to note a)	Line Bypassing work	12 months from the issue of OM by CTUIL.
2.	Reconductoring of Parli(PG) – Parli(M) 400kV D/c line section of above line (at Sl. 1) with twin HTLS conductor with a minimum capacity of 1940MVA per circuit at a nominal voltage (refer to note b)	Reconductoring length: About 5 km.	
3.	400kV Bay Upgradation work at Parli(M) S/s (Parli(M) S/s has a DMT scheme. The current rating of existing bays is 2000A which would be upgraded to 3150A to suit the reconductoring with Twin HTLS conductor)	400 kV line bays (Bay Upgradation) – 2 nos.	
Total Estimated Cost:			INR 26.64 Crore

Note:

- As per GA of Parli(PG) S/s, Parli(M) & Parli(New) 400kV D/c lines are getting terminated in adjacent bays on the same side of Parli(PG) S/s. Hence, the above would facilitate their interconnection and bypassing at Parli(PG) S/s.
- As informed by POWERGRID in the 8th CMETS-WR meeting, existing towers have been designed for sag corresponding to twin moose conductor at 85C design temperature. Hence, Reconductoring shall be possible on existing towers with GAP conductor to achieve 1400A per sub conductor or 1940MVA per ckt.
- Balance works at Parli(M) S/s end such as Bus coupler/Transfer Bus Coupler/Bus Upgradation to 3150A, as required, shall be taken up by MSETCL in matching time-frame of the reconductoring scheme (WRES-XXX).
- Due to the volatility in the metal market scrap value of aluminum conductors may be highly variable at this time. Considering this, the scrap value of the existing ACSR Moose conductor shall be deducted as per the prevailing scrap value to arrive at the final cost of the project.

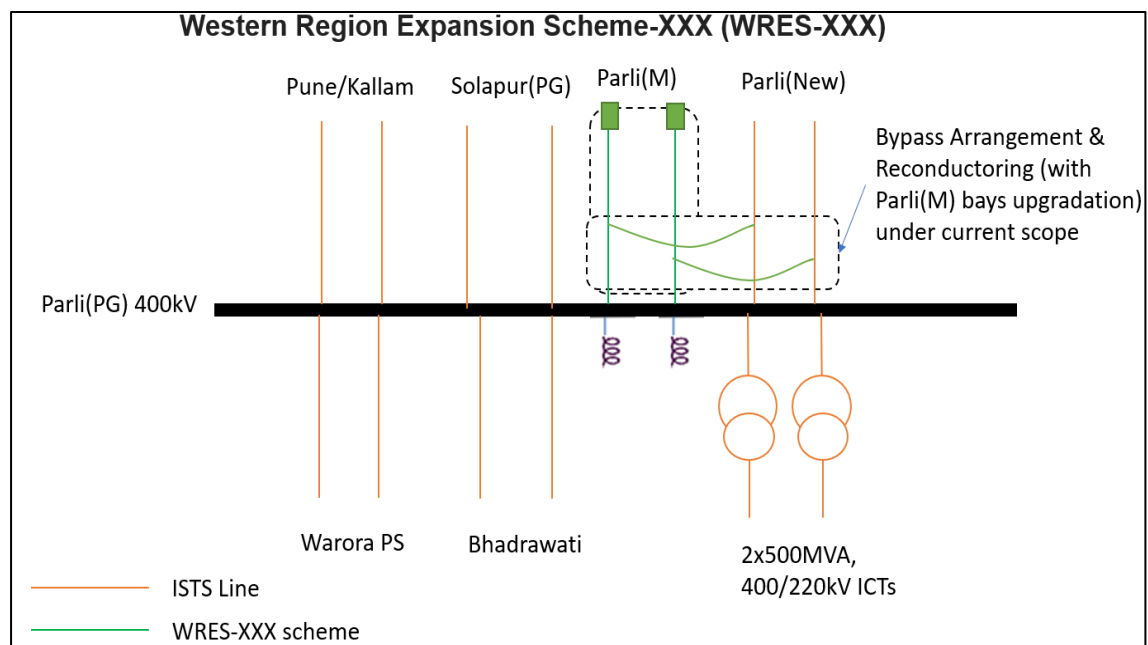

Figure 5-3: Western Region Expansion Scheme-XXX (WRES-XXX)

The scheme was allotted to POWERGRID vide CTU OM dated 25.08.2022 with implementation timeframe as given above.

b. Western Region Expansion Scheme XXXI (WRES-XXXI): Part A to C

The need for holistic ISTS & Intra-state transmission system planning for Maharashtra was deliberated in various CMETS-WR meetings (4th & 6th Meetings) and well as in meeting with MSETCL (for Wardha fault level control scheme) on 23.06.2022 from load flow as well as short circuit point of view. In this respect, the proposals of MSETCL received regarding 400kV D/c Interconnection between Padghe (PG)(GIS) and Padghe(M), splitting of Padghe(M) S/s for fault level control and Boisar – Manor 220kV D/c line were decided to be finalized in the course of joint study meeting with MSETCL.

In this regard, 3rd Joint Study Meeting on Transmission Planning for Western Region was held on 27.07.2022 amongst CTU, GRID INDIA and MSETCL to discuss transmission network augmentation w.r.t. Maharashtra. The following Network expansion schemes in Maharashtra under ISTS (with their tentative time-frame) were agreed:

- To meet the ATC requirement of ~24600MW of Maharashtra in 2026-27 time-frame
- To cater to fault level control at various substations (both ISTS & Intra-state) in Maharashtra

➤ **Western Region Expansion Scheme XXXI (WRES-XXXI): Part A**

(i) LILO of Tarapur/Velgaon – Padghe (M) 400kV D/c line at Kudus(M) S/s in following manner so as to form Padghe(PG)(GIS) – Padghe(M) 400kV D/c line and Tarapur/Velgaon - Kudus(M) 400kV D/c line:

1. Line-out portion for interconnection of Padghe(M) with Kudus(M) S/s to be constructed with HTLS conductor with minimum capacity of 2100MVA per ckt at nominal voltage and terminated directly into Padghe(PG)(GIS) – Kudus(M) 400kV D/c (quad) line at outskirts of Kudus(M) S/s so as to form Padghe(PG)(GIS) – Padghe(M) 400kV D/c line. 2 nos. 400kV bays shall get vacated with above arrangement.
2. Reconductoring of Padghe(M) - Kudus D/c balance line section (i.e. of existing line portion upto the proposed LILO point) with HTLS conductor with minimum capacity of 2100MVA per ckt at nominal voltage
3. Line-in portion for interconnection of Tarapur/Velgaon with Kudus(M) S/s to be terminated into 2 nos. bays vacated at Kudus (M) S/s (at Sl. 1 above)

(ii) Shifting of Padghe(PG)(GIS) – Padghe(M) 400kV D/c line from 400kV Section A to Section B

Note:

- MSETCL shall implement splitting arrangement at 400/220kV Padghe(M) as per arrangement at Annexure-II in matching time-frame of above scheme.
- Implementation Time-frame shall be 18 months from allocation to implementing agency or matching with Bableswar – Kudus 400kV D/c line of MSETCL (presently expected by Dec'23), whichever is later

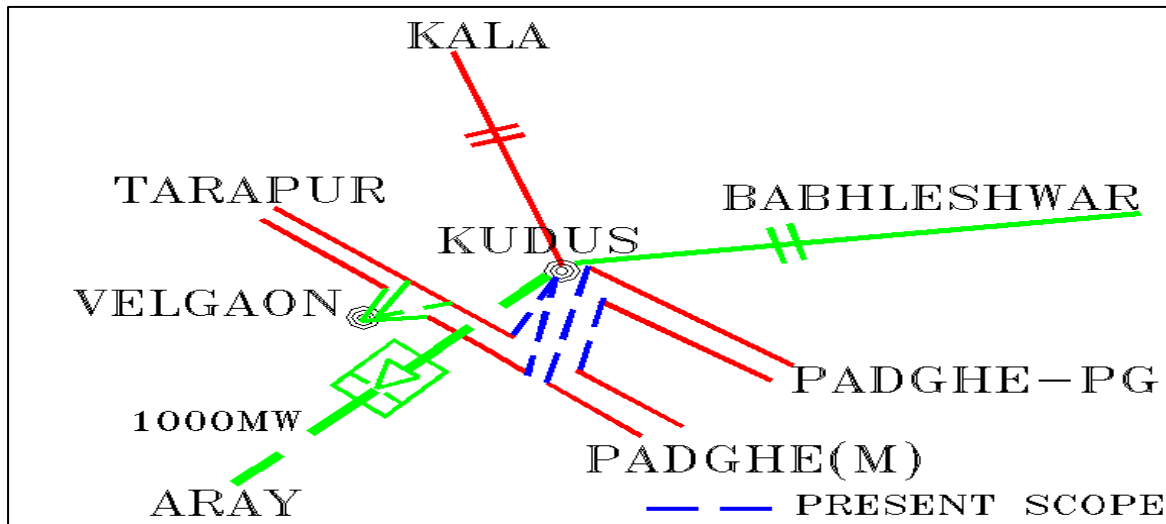

Figure 5-4: Western Region Expansion Scheme XXXI (WRES-XXXI): Part A

➤ **Western Region Expansion Scheme XXXI (WRES-XXXI): Part B**

- (i) Augmentation of transformation capacity at Padghe (GIS) 765/400 kV substation by 1x1500 MVA ICT (4th)

Note:

- Space availability at Padghe(PG)(GIS) S/s has been confirmed by POWERGRID.
- Implementation Time-frame shall be 18 months from allocation to implementing agency

➤ **Western Region Expansion Scheme XXXI (WRES-XXXI): Part C**

- (i) Augmentation of transformation capacity at Pune (GIS) 765/400 kV substation by 1x1500 MVA ICT (3rd)

Note:

- Space availability at Pune (PG)(GIS) S/s has been confirmed by POWERGRID.
- Implementation Time-frame shall be 18 months from allocation to implementing agency

To supplement above schemes, Intra-state schemes including Splitting of 400/220kV Kalwa S/s was also agreed to be implemented by MSETCL.

The “Western Region Expansion Scheme XXXI (WRES-XXXI): Part C” scheme has been agreed in the 10th CMETS-WR meeting held on 30.08.2022. The above scheme was allotted to POWERGRID vide CTU OM dated 28.11.2022 with implementation timeframe of 18 months from allocation at an estimated cost of Rs 86 Cr. The rest of the schemes would be deliberated in the forthcoming CMETS-WR / NCT meetings based on feedback from MSTECL w.r.t. WRES-XXXI Part A scheme and based on loading on Padghe (GIS) 765/400 kV ICTs w.r.t. WRES-XXXI Part B scheme.

c. Transmission System in Maharashtra in WR for Prioritized RE Potential under 181.5GW REZ plan for achievement of 500GW RE Target by 2030

In order to achieve the commitment made in terms of Nationally Determined Contributions (NDCs), as one of the significant steps, India has pledged to increase the non-fossil fuel energy capacity to 500 GW by 2030. This is a national mission as a part of the country's energy transition goal.

MNRE vide letter No. 367-13/1/2021-GEC dated 15.02.2022 addressed to Joint Secretary (Trans), MoP, had forwarded the Renewable Energy Zones (REZs) identified by MNRE/SECI with a total capacity of 181.5 GW for likely benefits by the year 2030. These REZ's are located in eight states as detailed below:

Sl. No.	State	Wind (GW)	Solar (GW)	Total (GW)	Remarks
1	Rajasthan	15	60	75	45 GW in GIB Zone
2	Andhra Pradesh	18	33	51	
3	Karnataka	8	9	17	
4	Tamil Nadu	5		5	Offshore wind
5	Telangana	3	10	13	
6	Madhya Pradesh	2	6	8	
7	Gujarat	5		5	Offshore wind
8	Maharashtra	2	5.5	7.5	
	Total	58	124	181.5	

In this regard, Ministry of Power vide letter No. 15-3/2017-Trans (part 1) dated 7th December, 2021, had constituted a Committee on Transmission Planning for RE under the Chairmanship of Chairperson, CEA, for planning of the requisite Inter- State Transmission System required for the targeted RE capacity by 2030. The committee had submitted its report in this regard to MoP in Dec'22.

Further, out of 181.5GW REZ, SECI vide letter dated 23.06.2022 has informed that as a first step to provide RTC Power (with wind, solar & storage components), they have identified certain locations with high solar & wind potential where work on RE evacuation system may be taken up immediately. The details of envisaged transmission system for integration and evacuation of RE potential from Solapur, Dhule and Kallam/Parli in Maharashtra as deliberated in various meetings are given below:

Proposed location of ISTS Pooling Station	RE development proposed under 181.5 GW plan & to be taken up on priority	Transmission System & deliberations
Solapur, MH	1 GW (Solar)	<ul style="list-style-type: none"> The scheme was deliberated in the 13th CMETS-WR meeting held on 08.12.2022, wherein, it was informed that no additional scheme is envisaged for evacuation of power

Proposed location of ISTS Pooling Station	RE development proposed under 181.5 GW plan & to be taken up on priority	Transmission System & deliberations												
		<p>of power from 1GW addl. SEZ in Solapur as the same may be accommodated at Solapur(PG) S/s at 400kV level (at 1 no. 400kV bay already earmarked at the S/s for evacuation of 1GW capacity under 66.5GW REZ scheme, which is currently on hold due to non-identification of any RE project). With this 1GW addl. Potential, the 400kV bay shall now cater to 2GW injection directly at Solapur (PG) S/s.</p> <ul style="list-style-type: none"> 400kV bay at Solapur (PG) end shall be implemented by Renew Green Energy Solutions Private Limited (RGESPL). 												
Dhule, MH	2 GW (Wind+Solar)	<p>The scheme was agreed in 11th CMETS-WR meeting held on 30.09.2022 and was also approved in 11th NCT meeting held on 29.12.2022. Following scheme was proposed for Dhule 2GW REZ:</p> <table border="1" data-bbox="587 996 1385 2018"> <thead> <tr> <th data-bbox="587 996 646 1086">Sl. No.</th> <th data-bbox="646 996 959 1086">Scope of the Transmission Scheme</th> <th data-bbox="959 996 1385 1086">Capacity /km</th> </tr> </thead> <tbody> <tr> <td data-bbox="587 1086 646 1597">1.</td> <td data-bbox="646 1086 959 1597">Establishment of 4x500 MVA, 400/220 kV Pooling Station near Dhule along with 2x125 MVA (420kV) Bus Reactor</td> <td data-bbox="959 1086 1385 1597">400/220 kV, 500 MVA ICT – 4 nos. 400 kV ICT bays – 4 nos. 220 kV ICT bays – 4 nos. 400 kV Line bays – 2 nos. 125 MVA, 420 kV Bus reactor – 2 no. Bus reactor bay: 2 no. 220kV Bus coupler bay- 1 no. 220kV Transfer Bus Coupler (TBC) bay - 1 no. 220 kV line bays – 7nos. (for RE interconnection)</td> </tr> <tr> <td data-bbox="587 1597 646 1753">2.</td> <td data-bbox="646 1597 959 1753">Dhule PS – Dhule (BDTCL) 400 kV D/c Line (Quad Moose) (60 km)</td> <td data-bbox="959 1597 1385 1753">60km.</td> </tr> <tr> <td data-bbox="587 1753 646 2018">3.</td> <td data-bbox="646 1753 959 2018">2 nos. 400kV line bays at Dhule(BDTCL) for Dhule PS – Dhule (BDTCL) 400 kV D/c Line (Quad Moose)</td> <td data-bbox="959 1753 1385 2018">400 kV Line bays – 2 nos.</td> </tr> </tbody> </table>	Sl. No.	Scope of the Transmission Scheme	Capacity /km	1.	Establishment of 4x500 MVA, 400/220 kV Pooling Station near Dhule along with 2x125 MVA (420kV) Bus Reactor	400/220 kV, 500 MVA ICT – 4 nos. 400 kV ICT bays – 4 nos. 220 kV ICT bays – 4 nos. 400 kV Line bays – 2 nos. 125 MVA, 420 kV Bus reactor – 2 no. Bus reactor bay: 2 no. 220kV Bus coupler bay- 1 no. 220kV Transfer Bus Coupler (TBC) bay - 1 no. 220 kV line bays – 7nos. (for RE interconnection)	2.	Dhule PS – Dhule (BDTCL) 400 kV D/c Line (Quad Moose) (60 km)	60km.	3.	2 nos. 400kV line bays at Dhule(BDTCL) for Dhule PS – Dhule (BDTCL) 400 kV D/c Line (Quad Moose)	400 kV Line bays – 2 nos.
Sl. No.	Scope of the Transmission Scheme	Capacity /km												
1.	Establishment of 4x500 MVA, 400/220 kV Pooling Station near Dhule along with 2x125 MVA (420kV) Bus Reactor	400/220 kV, 500 MVA ICT – 4 nos. 400 kV ICT bays – 4 nos. 220 kV ICT bays – 4 nos. 400 kV Line bays – 2 nos. 125 MVA, 420 kV Bus reactor – 2 no. Bus reactor bay: 2 no. 220kV Bus coupler bay- 1 no. 220kV Transfer Bus Coupler (TBC) bay - 1 no. 220 kV line bays – 7nos. (for RE interconnection)												
2.	Dhule PS – Dhule (BDTCL) 400 kV D/c Line (Quad Moose) (60 km)	60km.												
3.	2 nos. 400kV line bays at Dhule(BDTCL) for Dhule PS – Dhule (BDTCL) 400 kV D/c Line (Quad Moose)	400 kV Line bays – 2 nos.												

Proposed location of ISTS Pooling Station	RE development proposed under 181.5 GW plan & to be taken up on priority	Transmission System & deliberations
		<p>Est. Cost: Rs 637 Crs</p> <p>Implementation timeframe: 24 months from date of SPV transfer.</p>
Kallam / Parli, MH	2 GW (Wind+Solar)	<p>The scheme was deliberated in the 9th CMETS-WR meeting held on 28.07.2022. Following scheme was proposed for Parli/Kallam 2GW REZ:</p> <p><u>1 GW at Parli:</u></p> <p>a) <u>300MW at Parli(PG) 400/220kV S/s:</u></p> <ul style="list-style-type: none"> • Direct interconnection at 220kV level of 400/220 kV Parli (PG) S/s [through 1 no. 220kV line bay] <p>b) <u>700MW at Parli(New) 765/400kV S/s:</u></p> <ul style="list-style-type: none"> • Direct interconnection at 400kV level of 765/400 kV Parli (New) S/s [through 1 no. 400kV line bay] <p>300MW connectivity has been agreed for grant to Renew Tej Shakti Private Limited (RTSPL) at Parli (PG) S/s at 220kV with start date as 30.04.2025. Application yet to be received at Parli (New) S/s.</p> <p><u>1 GW at Kallam:</u></p> <ul style="list-style-type: none"> • Augmentation of Kallam Pooling Station by 2x500 MVA, 400/220kV ICTs • 2 nos. 220kV line bays at Kallam PS for RE interconnection • 1x125 MVAr bus reactor (2nd) at Kallam PS <p>The scheme was allotted to KTL vide CTU OM dated 15.11.2022 with implementation timeframe of Apr'24 at an estimated cost of Rs. 157 Cr.</p>

d. Transmission system for evacuation of power from RE projects in Solapur (1500MW) SEZ in Maharashtra

Under the GoI initiative of 500 GW capacity from non-fossil energy sources by 2030, about 3.5GW RE potential has been identified at Solapur out of which 2GW has been planned for direct injection at Solapur(PG) through 1 no. 400kV bay whereas the balance 1.5GW has been planned for injection at a New substation near Solapur (Solapur Pooling Point).

The present scheme has been planned for evacuation of power from RE projects in Solapur (1500MW) SEZ in Maharashtra. The scheme was deliberated in 15th CMETS-WR meeting held on 30.01.2023.

Detailed scope of the scheme is as under:

Sl. No.	Scope of the Transmission Scheme	Capacity/km	Timeframe
1.	Establishment of 400/220 kV, 4X500 MVA ICTs at Solapur PS alongwith 2x125 MVAR, 420 kV Bus Reactors Future provisions: Space to accommodate: <ul style="list-style-type: none"> • 400/220 kV, 500 MVA ICT along with associated bays – 6 nos. • 400 kV line bays along with switchable line reactors: 8 nos. • 420kV, 2x125MVAr Bus Reactor with Bays • 14 nos. of 220kV line bays • Sectionaliser arrangement at 220kV level (3 Sets) & 400kV level (1 Set) • 220kV TBC bay – 3 no. • 220kV BC bay – 3 no. 	400/220 kV, 500 MVA ICT – 4 [^] 400 kV ICT bays – 4 220kV ICT bays – 4 400 kV line bays – 2 220 kV line bays for solar park interconnection – 5 125 MVAr, 420 kV Bus reactor – 2 Nos 400 kV Bus reactor bay: 2 Nos. 220kV TBC bay – 1 no. 220kV BC bay – 1 no.	24 months from date of allocation to implementing agency.
2.	Solapur PS – Solapur (PG) 400 kV D/c line (Quad ACSR/AAAC/AL59 moose equivalent)	Route length ~30km (60ckm)	
^For meeting N-1 reliability criteria for 400/220kV ICTs			
Total Estimated Cost			Rs. 471.24 Cr.

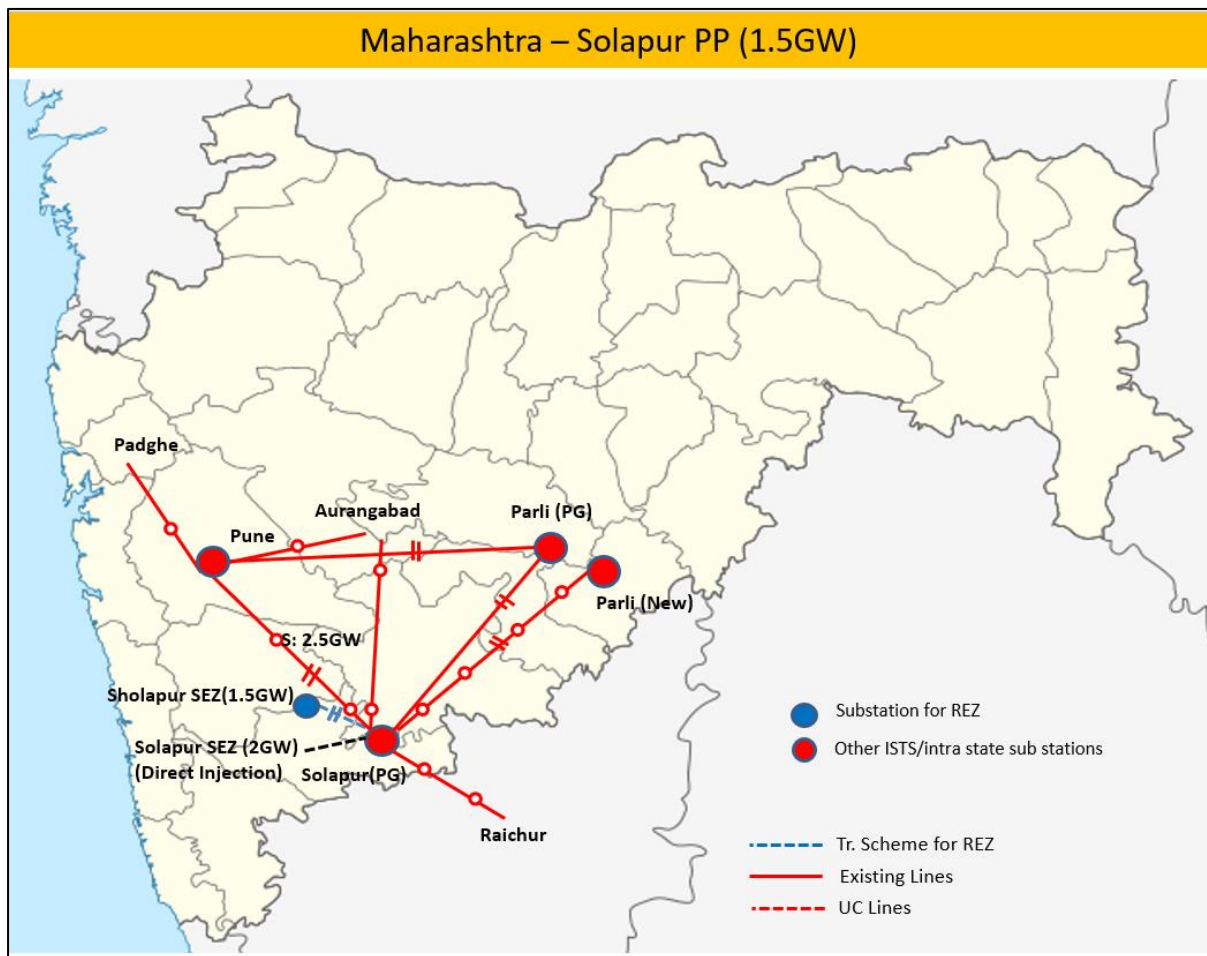

Figure 5-5: Tr. system for evacuation of power from RE projects in Solapur SEZ

5.4.3 Gujarat

a) Transmission system for evacuation of additional 7 GW RE power from Khavda RE park under Phase-III

Govt. of India has set a target for establishing 500 GW capacity from non-fossil energy sources by 2030. In this direction, in December 2020, Hon'ble Prime Minister laid the foundation stone of the world's largest renewable energy park in Gujarat's Kutch. This 30-Gigawatt (GW) capacity hybrid renewable energy park is being built along the Indo-Pak border at Khavda using both wind and solar energy and is expected to play a major role in fulfilling India's vision of generating 500 GW of non-fossil generation capacity by 2030.

Land had been allocated to various renewable energy projects in the Renewable Energy Park at Khavda located near International Border in Kutch, Gujarat for a total capacity of 27.7GW. However, after considering reduction of capacity allocated to SECI from 3GW to 1GW as communicated by SECI in meeting organized by GPCL on 19.01.2022, the total capacity in Khavda area works out to 25.8GW (after reduction in SECI quantum by ~2GW) out of which about 15GW RE capacity is expected to come up by 2024-25 and balance by 2026-27 time-frame. Additional capacity upto 30GW (~4GW) may be anticipated after 2026-27.

Transmission system for evacuation of upto 8GW power from Khavda RE Park has already been evolved in 3 phases as per details below:

Phase	RE Capacity (GW)	Status of Transmission System
I	3	Under Implementation – SCOD of Jan'24
II	5	Under Bidding – Expected SCOD of Feb'25

To cater to above potential, three pooling stations namely KPS1, KPS2 and KPS3 are being implemented in Khavda RE Park.

Sl. No.	Pooling Station	Location	Total RE capacity (GW) by 2026-27	Phase-I to III (By Mar'25)	
				Likely RE capacity (GW) by 2024-25*	RE Capacity considered for Planning study
1	Khavda Pooling Station-I (KPS1)	Near AGEL Plot	9.03	6.8	7
2	Khavda Pooling Station-II (KPS2)	Near GSECL/ GIPCL/ NTPC/ SRL Plot (Centre)	9.25	5.055	5
3	Khavda Pooling Station-III (KPS3)	Near SECI/ NTPC/SRL Plot (Top)	7.52	2.8	3
			25.8	14.655	15

*As per inputs from RE developers in meeting organized by GPCL on 19.01.2022

As agreed in 3rd WRPC(TP) meeting for evacuation of additional 7GW from Khavda area (beyond 8 GW), KPS2 – Halvad – Vataman – Navsari(new) 765kV D/c line corridor is proposed. The new 765kV switching station at Halvad is proposed through LILO of Lakadia – Ahmedabad 765 kV D/c line at Halvad. Similarly, the new 765kV switching station at Vataman is proposed through LILO of Lakadia – Vadodara 765 kV D/c line at Vataman. The scheme was also deliberated and agreed in the 12th Consultation Meeting for Evolving Transmission Schemes in Western Region (CMETS-WR) held on 19.10.2022 at an estimated cost of about Rs. 7420 Crores. Details of the 7GW scheme is given below:

Detailed scope of Transmission system for evacuation RE power from Khavda RE park under Phase-III

- Establishment of 765 kV Halvad switching station with 765 kV, 2x330 MVA bus reactors [with 110 MVA & 80 MVA 765kV single phase reactor (spare unit for bus/line reactors at Halvad)]
- KPS2- Halvad 765 kV D/c line (~220 km length) with 240 MVA switchable line reactor at both ends and 80 MVA single phase spare reactor unit at KPS2 end.
- LILO of Lakadia – Ahmedabad 765 kV D/c line at Halvad (LILO length~50 km)

- 240 MVA 765 kV switchable line reactor on each ckt at Halvad end of Halvad – Ahmedabad 765 kV D/c line (~220 km length)
- Halvad – Vataman 765 kV D/c line (~170 km length) with 1x330 MVA switchable line reactor at Vatman end on each ckt.
- Establishment of 765 kV switching station near Vataman with 2x330MVA, 765 kV bus reactor [with 110 MVA 765 kV single phase reactor (spare unit for bus/line reactor)]
- LILO of Lakadia – Vadodara 765 kV D/c line at Vataman 765 kV switching station (~10 km LILO length).
- Vataman switching station – Navsari (New) 765 kV D/c line (~200 km length) with 330 MVA switchable line reactors on each ckt at Navsari (New) end.
- Conversion of 240 MVA 765 kV switchable line reactor on each ckt at Lakadia end of Lakadia – Ahmedabad 765 kV D/c line (being LILOed at Halvad) into bus reactors with NGR bypassing arrangement.
- Conversion of 330 MVA 765 kV switchable line reactor on each ckt at Vadodara end of Lakadia – Vadodara 765 kV D/c line (being LILOed at Vataman) into bus reactors with NGR bypassing arrangement.
- Augmentation of transformation capacity at Navsari (New) 765/400kV by 1x1500MVA (ICT-IV)

Note:

- i. *Transmission system for evacuation of 3 GW RE injection at Khavda is being taken up under Phase-I and 5GW RE injection is being taken up under Phase-II. Accordingly, Phase-III scheme for evacuation of 7 GW RE injection at Khavda needs to be taken up for evacuation requirement beyond 8 GW from Khavda RE park.*
- ii. *Implementation timeframe shall be 24 months from date of allocation to implementing agency or matching with schedule of connectivity application / scheduled COD of RE project[based on award of first bid of RE project by REIA beyond 8GW at Khavda (whichever is later)].*

Transmission system for Evacuation of Power from potential renewable energy zone in Khavda area of Gujarat (beyond 15GW)

As on date in Khavda area, Stage-II connectivity applications for 19.205GW (KPS-I: 9GW, KPS-II: 3.755GW & KPS-III: 6.45GW) have already been received. Considering the rapid pace of applications being received in Khavda area and the directions received in the meeting convened under the Chairmanship of Hon'ble Minister (New & Renewable Energy and Power) held on 30th November, 2022, it is imperative to plan for transmission system for entire 30GW Khavda RE Park in advance so that there is no mismatch between RE generation and transmission.

A meeting was held amongst CEA, CTU, WRPC, GRID-INDIA, GETCO & MSETCL on 19.12.2022 to discuss transmission system for Evacuation of Power from potential renewable energy zone in Khavda area of Gujarat (beyond 15GW), wherein, comprehensive transmission plan for evacuation of balance 15GW RE potential in Khavda RE Park has been evolved in phases as given below (refer schematic at the end).:

- Phase-IV (For Generation between Jun'25 to Jun'26): 7GW – HVAC System
- Phase-V (For Generation by Dec'26/Mar'27 & Beyond): 8GW – HVDC System (8GW)

The RE capacity planned in each of the phases IV & V is detailed below:

Sl. No.	Pooling Station	Phase-IV (Jun'25 to Jun'26)		Phase-V (by Dec'26/Mar'27)	
		Likely RE capacity (GW)	Cumulative RE Capacity considered for Planning	Total RE capacity (GW)	Cumulative RE Capacity considered for Planning
1	Khavda Pooling Station-I (KPS1)	9.03	9	9.03	9
2	Khavda Pooling Station-II (KPS2)	8.68	9	9.25	9.5
3	Khavda Pooling Station-III (KPS3)	3.94	4	7.52	7.5
	Total	21.65	22	25.8	26

Pooling station-wise RE capacity for balance (4GW) is not available.

The following system was agreed for Evacuation of Power from potential renewable energy zone in Khavda area of Gujarat (beyond 15GW):

Name of Scheme	State(s)	Tentative Cost (Rs. Crore)
Transmission System for Evacuation of Power from potential renewable energy zone in Khavda area of Gujarat under: <ul style="list-style-type: none"> • Phase-IV (7GW) • Phase-V (8GW) 	Gujarat & Maharashtra	Ph-IV: 12337 Ph-V: 23334
Provision of Dynamic Reactive Compensation at KPS1, KPS3 & Navsari(New) Substations	Gujarat	681
		36352 Cr.

b) Transmission System for Evacuation of Power from potential renewable energy zone in Khavda area of Gujarat under Phase-IV (7GW)

Details of Transmission System:

Part A

- KPS3 – KPS2 765kV 2nd D/c line (20km.) along with creation of 765kV & 400kV bus section-2 at KPS3 and installation of ± 300 MVAr STATCOM with 1x125 MVAr MSC, 2x125 MVAr MSR at KPS3 400kV Bus section-2

Note: Bay(s) as may be required for completion of diameter (GIS) in one-and-half breaker scheme, shall also be executed by the TSP.

- KPS1 – Bhuj 765kV 2nd D/c line (60km.)

Note: Bay(s) as may be required for completion of diameter (GIS) in one-and-half breaker scheme, shall also be executed by the TSP.

- KPS2 – Lakadia 765kV 2nd D/c line with 330 MVAR switchable line reactors at KPS2 end of KPS2 (GIS) – Lakadia 765 kV 2nd D/C line (with NGR bypass arrangement) (160km.)

Note: Bay(s) as may be required for completion of diameter (GIS) in one-and-half breaker scheme, shall also be executed by the TSP.

- Vadodara – Navsari(New) 765kV D/c line with 240 MVAR switchable line reactors at Vadodara(GIS) end of Vadodara(GIS) – Navsari(New)(GIS) 765 kV D/C line (with NGR bypass arrangement) (120km.)

Note: Bay(s) as may be required for completion of diameter (GIS) in one-and-half breaker scheme, shall also be executed by the TSP.

Part-B

- Establishment of 765/400/220kV Boisar-II (GIS) S/s (3x1500, 765/400kV & 2x500MVA, 400/220kV) with 2x330MVA 765kV and 2x125MVA 420kV bus reactors
- Navsari(New) – Boisar-II 765kV D/c line with 330 MVAR switchable line reactors at Navsari(New) end of Navsari(New) – Boisar-II 765kV D/c line (with NGR bypass arrangement) (175km.)
- LILO of Navsari(New) – Padghe(PG) 765kV D/c line at Boisar-II (LILO route length 25km.)
- Boisar-II – Velgaon(MH) 400kV D/c (Quad ACSR/AAAC/AL59 moose equivalent) line (10km.)
- LILO of Babhaleswar – Padghe(M) 400kV D/c line at Bosar-II using twin HTLS conductor with minimum capacity of 1700MVA per ckt at nominal voltage (LILO route length 65km.) and with 80 MVAR switchable line reactors at Bosar-II end of Boisar-II – Babhaleswar 400kV D/c line (with NGR bypass arrangement)
- ± 300MVA STATCOM with 3x125 MVA MSC, 1x125 MVA MSR at 400kV level of Boisar-II

Note:

1. Bay(s) as may be required for completion of diameter (GIS) in one-and-half breaker scheme, shall also be executed by the TSP.
2. MSETCL shall carry out reconductoring of the balance portion of Padghe(M) – Boisar-II 400kV D/c line (i.e. from LILO point upto Padghe(M)) and shall also carry out upgradation of 400kV bays at Padghe(M) as may be required in matching time-frame of the LILO line. **MSETCL confirmed maximum capacity of line which can**

be achieved after reconductoring considering clearances in existing towers of Babhaleswar – Padghe(M) 400kV D/c line as 1700MVA per ckt.

3. *MSETCL shall implement the LILO of both circuits of Boisar-II – Velgaon 220kV D/c line at Boisar-II (ISTS) S/s along with 4 nos. 220kV GIS bays at Boisar-II in matching time-frame of Boisar-II (ISTS) S/s*

Part-C

- Establishment of 765/400/220kV Pune-III (GIS) S/s (2x1500, 765/400kV & 3x500MVA, 400/220kV) with 2x330MVAR 765kV and 2x125MVAR 420kV bus reactors
- Boisar-II – Pune-III 765kV D/c line (200km.) along with 330 MVAR switchable line reactors at Pune-III end of Boisar-II – Pune-III 765kV D/c line (with NGR bypass arrangement).
- LILO of Narendra(New) – Pune(GIS) 765kV D/c line at Pune-III (LILO route length 10km.) along with 330 MVAR switchable line reactors at Pune-III end of Narendra(New) – Pune-III(GIS) 765kV D/c line (with NGR bypass arrangement).
- Inter tripping scheme on 330MVAR SW LR at Pune(GIS) end of Pune(GIS) – Pune-III(GIS) 765kV D/c line
- LILO of Hinjewadi-Koyna 400kV line at Pune-III(GIS) S/s along with 80MVAR, 420kV switchable Line Reactors on each ckt at Pune-III(GIS) end of Pune-III(GIS) – Koyna 400kV line

Note:

1. *Bay(s) as may be required for completion of diameter (GIS) in one-and-half breaker scheme, shall also be executed by the TSP.*
2. *Logic for Inter tripping scheme for tripping of the 330MVAR switchable line reactor alongwith main line breaker at Pune(GIS) end of Pune(GIS) – Narendra (New) 765kV D/c line shall be implemented by the owner of the line after LILO of Narendra(New) – Pune(GIS) 765kV D/c line at Pune-III*
3. *MSETCL shall implement the following 220kV lines from Pune-III (GIS) S/s in matching time-frame of Pune-III S/s:*
 - ✚ *LILO of both circuits of Jejuri-Phursungi 220kV D/c line at Pune-III S/s along with 4 nos. 220kV GIS bays at Pune-III(GIS) with HTLS conductor (twin zebra equivalent) along with reconductoring of balance line section viz. LILO point to Phursungi and LILO point to Jejuri with HTLS conductor (twin zebra equivalent)*
 - ✚ *Nanded city - Pune PG III 220kV S/c line with HTLS conductor (twin zebra equivalent)*
4. *Benefits of Downstream system from Pune-III (as informed by MSETCL):*
 - ✚ *The 220 kV level creation at 765kV Shikrapur PG s/s with establishment of 2 x 500 MVA, 400/220 kV ICTs capacity will relieve the loading on existing ICTs at 400kV Jejuri S/S.*
 - ✚ *Three 220kV S/s namely, Phursungi, Nandedcity & Kondhwa will get strong source through 765/400 kV Pune PG III s/s.*
 - ✚ *400kV Hinjewadi S/s will get strong Source of 765kV New Pune PG III S/s*
 - ✚ *With establishment of 765kV Pune PG III s/s the transmission network of Pune Ring main in Pune District will be strengthened and operational efficiency of 220kV network will be improved.*

Part-D

- Augmentation of transformation capacity at KPS1(GIS) by 1x1500MVA, 765/400kV ICT (8th)

Note: Bay(s) as may be required for completion of diameter (GIS) in one-and-half breaker scheme, shall also be executed by the TSP.

- Augmentation of transformation capacity at KPS2(GIS) by 1x1500MVA, 765/400kV ICT (8th) on Bus section-II

Note: Bay(s) as may be required for completion of diameter (GIS) in one-and-half breaker scheme, shall also be executed by the TSP.

- Augmentation of transformation capacity at KPS3(GIS) by 1x1500MVA, 765/400kV ICT (4th) on Bus section-I

Note: Bay(s) as may be required for completion of diameter (GIS) in one-and-half breaker scheme, shall also be executed by the TSP.

Note:

- ❖ Downstream system from Boisar-II & Pune-III has been finalised in coordination with MSETCL
- ❖ **Implementation time-frame:** 24 months from date of allocation to implementing agency

c) Transmission System for Evacuation of Power from potential renewable energy zone in Khavda area of Gujarat under Phase-V (8GW)

- Establishment of 8000 MW, \pm 800 kV KPS2 (HVDC) [LCC] terminal station (4x2000 MW) with 400/33 kV, 2x50 MVA transformers for exclusively supplying auxiliary power to HVDC terminal.
- Establishment of 8000 MW, \pm 800 kV Akola-III (HVDC) [LCC] terminal station (4x2000 MW)
- \pm 800 kV HVDC Bipole line between KPS2(HVDC) and Akola-III(HVDC) (1000km.) (with Dedicated Metallic Return) (capable to evacuate 8000MW with overload capacity as specified)
- Establishment of 8x1500MVA, 765/400kV ICTs at Akola-III(HVDC) along with 2x330 MVAR (765kV) & 2x125MVAR, 420kV bus reactors. The 400kV bus shall be established in 2 sections through 1 set of 400kV bus sectionaliser so that 4x1500MVA ICTs are placed in each section.
 - 765/400 kV, 1500 MVA ICT-8
 - 765 kV ICT bays- 8
 - 400 kV ICT bays- 8*
 - 330 MVAR 765 kV bus reactor-2
 - 125 MVAR 420 kV bus reactor-2
 - 765 kV reactor bay- 2
 - 765 kV line bay- 4
 - 400 kV reactor bay- 2
 - 400 kV Bus sectionaliser- 1 Set

- 500 MVA, 765/400 kV Spare ICT-1
- 110 MVAR, 765 kV, 1-ph reactor (spare unit)-1

Future Scope at Akola-III: Space for

- 765 kV line bays along with switchable line reactors – 6 nos.
 - 765kV Bus Reactor along with bay: 2 no.
 - 765kV Sectionalizer bay: 1 -set
 - 400 kV line bays along with switchable line reactor – 10 nos.
 - 400/220kV ICT along with bays -4 nos.
 - 400 kV Bus Reactor along with bay: 2 no.
 - 220 kV line bays: 8 nos.
 - 220kV Sectionalization bay: 1 set
 - 220kV BC & TBC: 2 nos.
- LILO of Wardha – Aurangabad 765kV 2xD/c line at Akola-III (LILO route length 30km.)
 - HVDC System will be designed considering 100% power reversal capability and 133% continuous overload capability in forward direction (from KPS2 to Akola-III) under outage of one pole. As per the Central Electricity Authority (Technical Standards for Construction of Electrical Plants and Electric Lines) Regulations, 2022, the rated power transmission capacity shall be defined and guaranteed at inverter end of AC yard and rated transmission voltage shall be defined at the rectifier end.
 - Associated 400kV Interconnectors between HVDC and HVAC switchyard
 - Augmentation of transformation capacity at KPS2(GIS) by 1x1500MVA, 765/400kV ICT (9th) on Bus section-I

Note: Bay(s) as may be required for completion of diameter (GIS) in one-and-half breaker scheme, shall also be executed by the TSP.

- Augmentation of transformation capacity at KPS3(GIS) by 3x1500MVA, 765/400kV ICT (5th, 6th & 7th) on Bus section-II

Note: Bay(s) as may be required for completion of diameter (GIS) in one-and-half breaker scheme, shall also be executed by the TSP.

Note:

- ❖ The 2x2000MW poles shall emanate from 400kV bus section 1 of KPS2 and terminate at bus section 1 of Akola-III. Similarly, the 2x2000MW poles shall emanate from 400kV bus section 2 of KPS2 and terminate at bus section 2 of Akola-III.
- ❖ **Implementation time-frame:** 42 months from date of allocation to implementing agency

d) Provision of Dynamic Reactive Compensation at KPS1, KPS3 & Navsari(New) Substations

- ± 300MVAr STATCOM with 1x125 MVAr MSC, 2x125 MVAr MSR at KPS1 400kV Bus section-1
- ± 300MVAr STATCOM with 1x125 MVAr MSC, 2x125 MVAr MSR at KPS1 400kV Bus section-2
- ± 300MVAr STATCOM with 1x125 MVAr MSC, 2x125 MVAr MSR at KPS3 400kV Bus section-1

- ± 300MVAr STATCOM with 3x125 MVAr MSC, 1x125 MVAr MSR at 400kV level of Navsari (New)(PG) S/s

❖ **Implementation time-frame:** 24 months from date of allocation to implementing agency

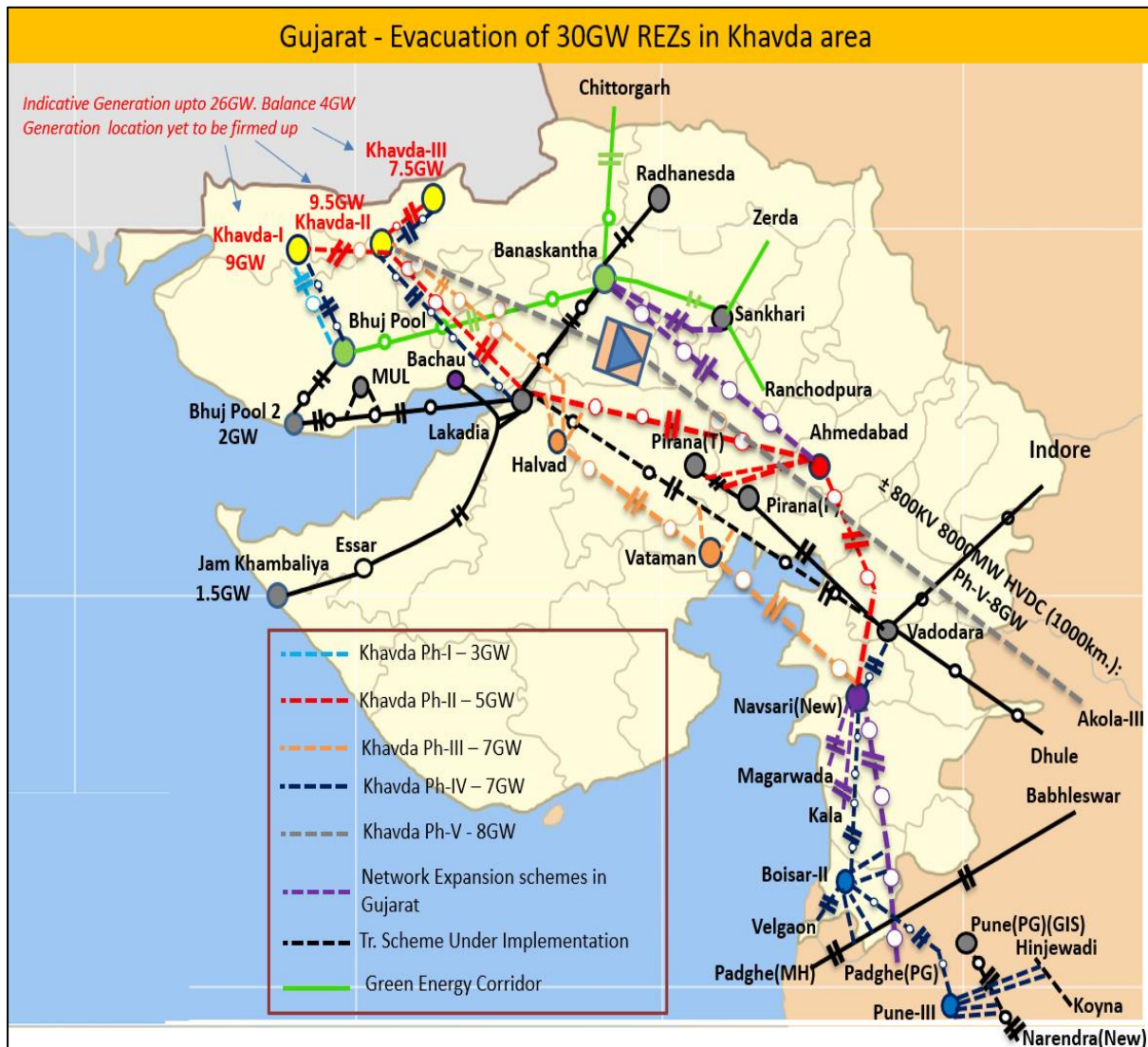

Figure 5-6: Tr. system for Evacuation of Power Khavda REZ

e) Scheme for drawal of 4000 MW power by MPSEZ UTILITIES LIMITED (MUL)

MPSEZ utilities Limited (MUL) as a Distribution Licensee in Kutch, Gujarat has projected a drawal requirement of about 10GW by 2030. To cater the huge drawl requirement, it was envisaged to plan supply of power to MUL through a new 765/400kV S/s near Navinal (Mundra) to be established vide LILO of Bhuj-II – Lakadia 765kV D/c line at Navinal (Mundra) (GIS) S/s.

The connectivity to be provided to MUL is for two drawl points from Navinal S/s, viz. MRSS-1 & MRSS-2. Further, initially LILO of one circuit of Bhuj-II – Lakadia 765kV D/c line along with 3x1500MVA ICTs at Navinal (Mundra) (GIS) S/s would be undertaken and additional 1500MVA, 765/400kV (4th) transformer along with LILO of the 2nd circuit at Navinal

(Mundra) (GIS) S/s shall be undertaken after receipt of LTA applications beyond 3000MW at Navinal (Mundra)(GIS) S/s. Accordingly, it has been envisaged to establish the complete scheme comprising of LILO of Bhuj-II – Lakadia 765kV D/c line at Navinal (Mundra) (GIS) alongwith 4 x1500MVA,765/400kV ICTs at Navinal (GIS) S/s.

Detailed scope of the scheme is as under:

Sl.	Scope of the Transmission Scheme	Capacity /km
1.	<p>Establishment of 4x1500 MVA, 765/400 kV Navinal (Mundra) S/s (GIS) with 2x330 MVAR, 765 kV & 1x125 MVAR, 420 kV bus reactors</p> <p>Future provision (space for):</p> <ul style="list-style-type: none"> ➤ 765/400 kV ICT along with bays- 2 Nos. ➤ 765 kV line bays along with switchable line reactors – 4 Nos. ➤ 765 kV Bus Reactor along with bay: 2 Nos. ➤ 765 kV Sectionalizer: 1 -set ➤ 400 kV line bays along with switchable line reactors– 6 Nos. ➤ 400/220 kV ICT along with bays -6 Nos. ➤ 400 kV Bus Reactor along with bays: 3 Nos. ➤ 400 kV Sectionalization bay: 1- set ➤ 220 kV line bays: 10 Nos. ➤ 220 kV Sectionalization bay: 1 set ➤ 220 kV BC and TBC: 2 Nos. ➤ STATCOM (± 300 MVAR) along with MSC (2x125 MVAR) & MSR (1x125 MVAR) and associated bays- 2 Nos. 	<p>765/400 kV, 1500 MVA ICT – 4 Nos. (13x500 MVA single phase units including one spare ICT Unit)</p> <p>765 kV ICT bays – 4 Nos.</p> <p>400 kV ICT bays – 4 Nos.</p> <p>765 kV Line bays – 4 Nos.</p> <p>1x330 MVAR, 765 kV bus reactor- 2 Nos. (7x110 MVAR single phase Reactors including one spare Unit for bus /line reactor)</p> <p>765 kV Bus reactor bay – 2 Nos.</p> <p>125 MVAR, 420 kV reactor- 1 Nos.</p> <p>400 kV Reactor bay- 1 No.</p>
2.	LILO of Bhuj-II – Lakadia 765 kV D/c line at Navinal (Mundra) (GIS) S/s with associated bays at Navinal (Mundra) (GIS) S/s	LILO Route length: 70 km (280 ckm)
3.	Installation of 1x330 MVAR switchable line reactor on each ckt at Navinal end of Lakadia – Navinal 765 kV D/c line (formed after above LILO)	<p>1x330 MVAR, 765 kV switchable line reactor– 2 Nos.</p> <p>Switching equipment for 765 kV line reactor – 2 Nos.</p>

The subject transmission system was approved in the 11th NCT meeting held on 28.12.2022 and 17.01.2023 at an estimated cost of about Rs 2200 Cr.

MUL vide letters dated 04.03.2023 have requested to defer further processing of their LTA applications. Hence, in the absence of any firm commitment from MUL, the scheme was agreed to be deferred as per the 12th NCT meeting held on 24.03.2023.

Note:

(i) **Implementation timeframe:** 21 months from date of SPV transfer.

(ii) The following scope of works for interconnection of MUL S/s (MRSS1 & 2) with Navinal (Mundra) S/s (GIS) is under the scope of MUL and is required to be implemented in the same time frame.

Sl.	Scope of works to be implemented by MUL	Capacity/km
1.	<p>Interconnection of MUL S/s (MRSS1 & 2) with Navinal (Mundra) S/s (GIS) as given below:</p> <p>(i) MUL MRSS-1 – Navinal (Mundra) 400 kV D/c (Twin HTLS - Quad Moose equivalent) line along with associated line bays Navinal end* (~1-2 km.)</p> <p>(ii) MUL MRSS-2 – Navinal (Mundra) 400 kV D/c (Twin HTLS - Quad Moose equivalent) line along with associated line bays Navinal end* (~1-2 km.)</p> <p>*4 Nos. 400 kV Line bays at MUL (MRSS1 & 2) end shall be implemented by MUL</p>	<p>Route Length- 1 km (approx.)</p> <p>400 kV line bays: 4 Nos.</p>

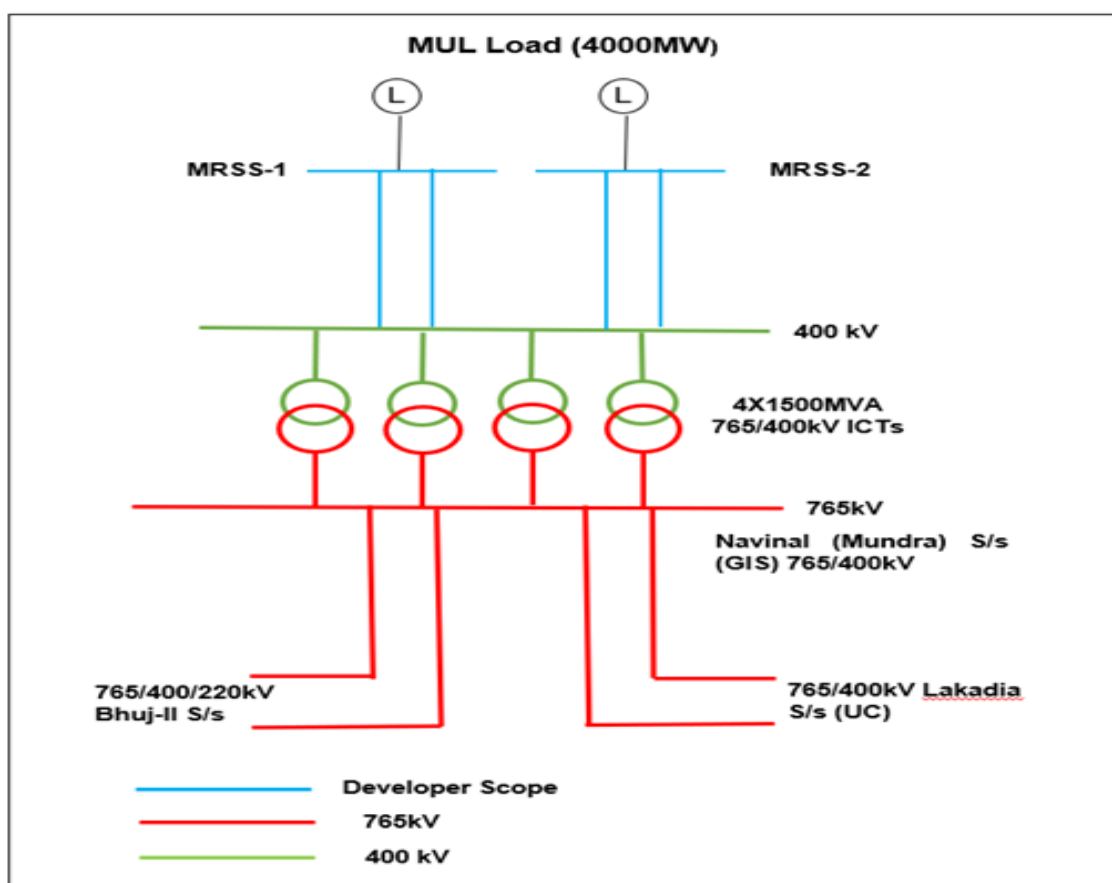

Figure 5-7: Scheme for drawal of 4000 MW power by MPSEZ

f) **Implementation of 1 no. 220kV line bay at Bhuj PS for providing Connectivity to M/s NTPC Renewable Energy Ltd. (NTPC REL) (300MW)**

Stage-II Connectivity of 300MW has been granted to NTPC REL at Bhuj-II for RE plant at Kutch, Gujarat. As per the grant of Connectivity, the bay at ISTS end i.e Bhuj PS shall be under the scope of ISTS Licensee. Accordingly, the scheme as per following details were approved to be implemented under Regulated Tariff Mechanism (RTM) by POWERGRID:

Sl.	Scope of the Transmission Scheme	Capacity /km	Implementation Timeframe
1	1 no. 220kV line bay at Bhuj PS associated with M/s NTPC Renewable Energy Ltd. (300MW)	220kV line bay: 1 no.	15 months from the date of issue of OM by CTUIL (refer note-a).
Total Estimated Cost:			INR 5.84 Crore

Note:

- a. Best efforts shall be carried out to implement the transmission scheme within 12 months from the issue of OM by CTUIL.

The above scheme was approved by CTU vide OM dated 28/11/2022, with POWERGRID as implementing agency.

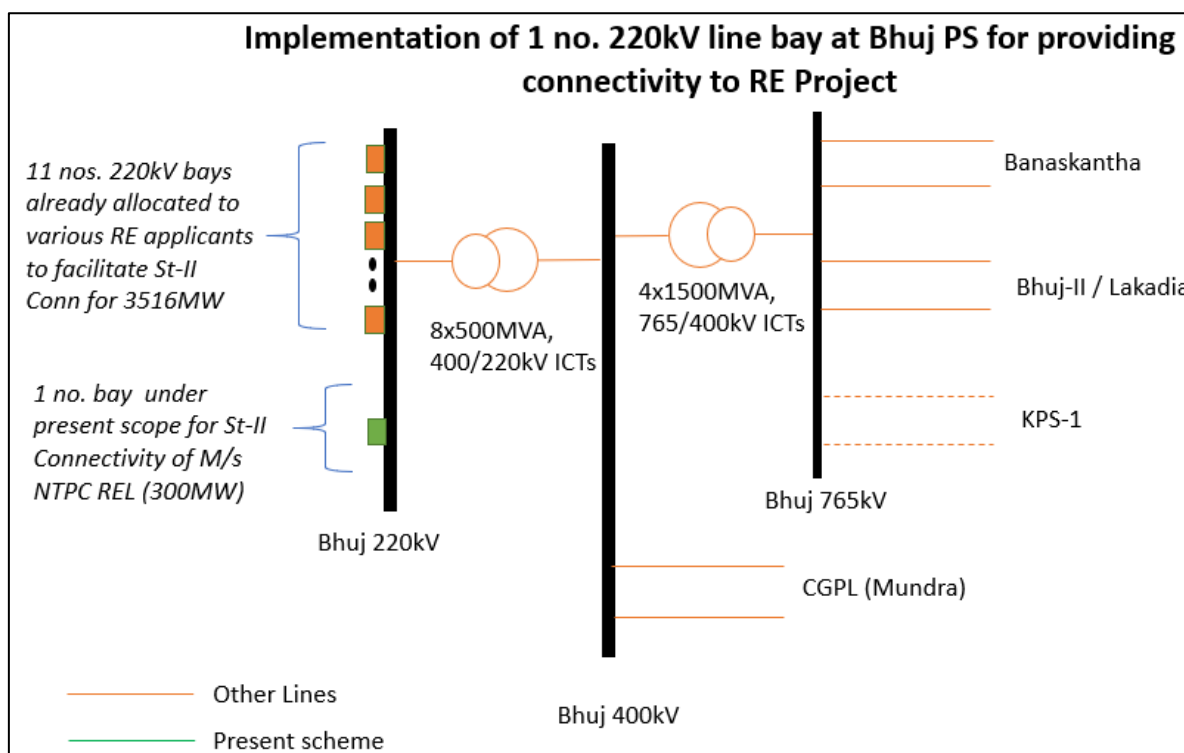

Figure 5-8: Implementation of 1 no. 220kV line bay at Bhuj PS for NTPC REL

g) Transmission scheme for injection beyond 3 GW RE power at Khavda PS2 (KPS2)

In the 11th meeting of NCT, CTU proposed augmentation by three (3) Nos. 765/400 kV, 1500 MVA ICTs at KPS2 (3rd & 4th on Bus Section-I and 3rd on Bus Section-II) at estimated cost of Rs 352.06 Crore to cater RE injection requirement at Khavda Pooling Station-2 (KPS2). The proposed time frame of implementation is 21 months from date of allocation/SPV transfer.

Estimated Cost: Rs. 352.06 Crs

Detailed scope of the scheme is as under:

Sl. No.	Scope of the Transmission Scheme	Capacity /km
1.	765/400 kV, 2x1500 MVA ICT augmentation (3rd & 4th on Bus Section-I) at KPS2	765/400 kV, 1500 MVA ICT – 2 765 kV ICT bays – Nil* 400 kV ICT bays – 1 (complete dia)*
2.	765/400 kV, 1x1500 MVA ICT augmentation (3rd on Bus Section-II) at KPS2	765/400 kV, 1500 MVA ICT – 1 765 kV ICT bays – 1 (complete dia)* 400 kV ICT bays – 1 (complete dia)*

*2 Nos. future 765 kV bays are available in Section -I at KPS2 (as per RfP). Hence 2x1500MVA ICTs shall be terminated in these future 765 kV bays. Further, 1 No. future 400 kV bay is available in Section -I at KPS2 (as per RfP). Hence 1x1500MVA ICT shall be terminated in this future 400 kV bays. Accordingly, 1 No. new dia at 765 kV KPS2 Section-II and 2 No. new dia at 400 kV Section-I & II respectively would be required as part of above augmentation work (in line with KPS2 RfP) in order to complete dia for the GIS S/s extension.

Implementation timeframe: 21 months from date of allocation/SPV transfer

5.4.4 Madhya Pradesh**a) Western Region Expansion Scheme XXXIII (WRES-XXXIII): Part A**

To overcome critical constraint on 400/220 kV, 2x315+1x500 MVA Jabalpur ICTs, joint studies were carried out and scheme for creation of 220 kV level at 765/400 kV Jabalpur PS with installation of 2x500 MVA, 400/220 kV ICTs along with LILO of Narsinghpur - Jabalpur (MP) 220 kV D/c line at Jabalpur PS was evolved. The scheme is envisaged to relieve high loadings on Jabalpur ICTs which were found to be 'N-1' non-compliant.

Detailed scope of the scheme is as under:

Sl. No.	Scope of the Transmission Scheme	Capacity /km	Implementation time-frame
3.	Creation of 220 kV level at 765/400 kV Jabalpur PS with Installation of 2x500 MVA, 400/220 kV ICTs along with associated ICT bays	400/220 kV, 500 MVA ICT – 2 nos. 400 kV ICT bay – 2 no. 220 kV ICT bay – 2 no.	18 months from date of allocation to implementing agency
4.	4 No. of 220 kV line bays at Jabalpur PS for LILO of Narsinghpur - Jabalpur (MP) 220 kV D/c line at Jabalpur Pool	220 kV line bay – 4 nos.	
Total Estimated cost			Rs.126.09 Crs.

Note: Developer of Jabalpur PS to provide space for implementation of abovementioned scope of works.

Implementation time-frame:

The above scheme was approved by CTU vide OM dated 14/02/2023, with POWERGRID as implementing agency.

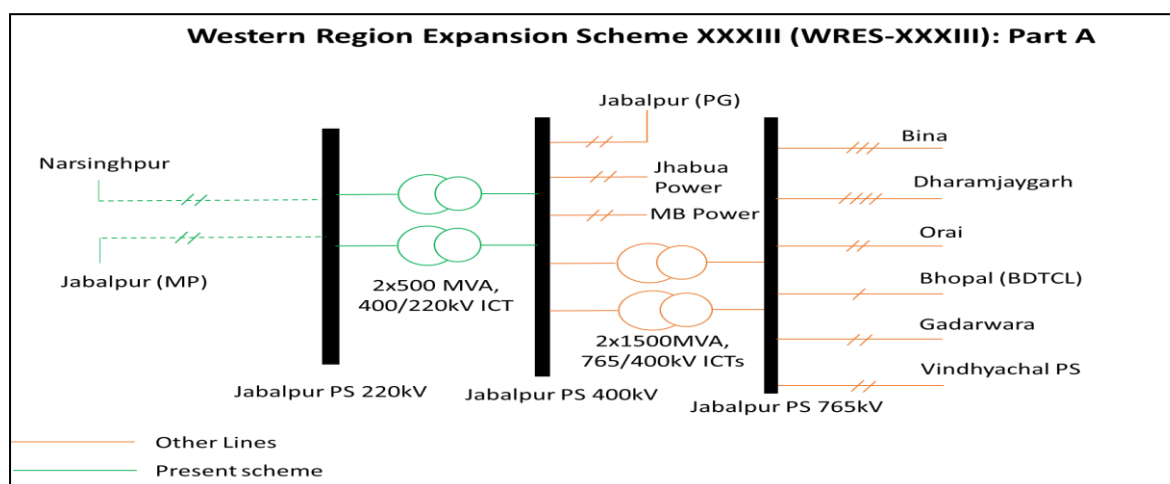

Figure 5-9: Western Region Expansion Scheme XXXIII

b) Western Region Expansion Scheme XXXIII (WRES-XXXIII): Part B

In order to address high loadings on Gwalior ICTs which were found to be N-1 non-compliant, a new Substation has been envisaged in South of Gwalior to cater to the increased demand in that area, which can also be used for grant of connectivity to M/s Greenko for their proposed 2520 MW PSP Project in future. After deliberations and system studies, establishment of 765/400kV, 2X1500MVA ICTS & 400/220kV, 2X500MVA Karera (Near Datiya) S/s through Satna-Gwalior 765kV S/c line was envisaged.

Detailed scope of the scheme is as under:

Sl.	Scope of the Transmission Scheme	Capacity /km
1.	<p>Establishment of 765/400 kV, 2x1500 MVA (7x500 MVA single phase units including spare unit), 400/220 kV, 2x500 MVA ICTs at Karera (near Datiya) along with 1x330 MVA 765 kV bus reactor (4x110 MVAR single phase units including one spare unit) & 1x125 MVA, 420 kV bus reactor</p> <p>Future space provision:</p> <ul style="list-style-type: none"> ➤ 765/400 kV ICT along with bays- 4 no. ➤ 765 kV line bays along with switchable line reactors – 8 nos. ➤ 765 kV Bus Reactor along with bay: 3 no. ➤ 765 kV Sectionalizer: 1 -set ➤ 400 kV line bays along with switchable line reactor – 10 nos. ➤ 400/220 kV ICT along with bays -6 nos. ➤ 400 kV Bus Reactor along with bay: 3 no. ➤ 400 kV Sectionalization bay: 1- set ➤ 220 kV line bays: 10nos. ➤ 220 kV Sectionalization bay: 1 sets ➤ 220 kV BC and TBC: 1 nos. 	<p>765/400 kV, 1500 MVA ICT – 2 nos. (7x500 MVA single phase units including one spare unit)</p> <p>400/220 kV, 500 MVA ICT – 2 nos.</p> <p>765 kV ICT bays – 2 nos.</p> <p>400 kV ICT bays – 4 nos.</p> <p>220 kV ICT bays – 2 nos.</p> <p>765 kV Line bays – 2 nos.</p> <p>330 MVA, 765 kV Bus Reactor – 1 no. (4x110 MVAR single phase units including one spare unit)</p> <p>125 MVA, 420 kV Bus reactor – 1 no.</p> <p>765 kV Bus reactor bay: 1 no.</p> <p>400 kV Bus reactor bay: 1 no.</p> <p>220 kV Bus coupler bay- 2 no.</p> <p>220 kV Transfer Bus Coupler (TBC) bay - 2 no.</p> <p>220 kV line bays – 8 nos.</p> <p>(for 220 kV lines to be implemented by MPPTCL#)</p> <p>220 kV Bus sectionalizer– 1 set.</p>
2.	LILO of Satna-Gwalior 765 kV S/c line at Karera	LILO length ~ 70 km (140 ckm)
3.	Installation of 1x330 MVA, switchable line reactor at Karera end of Karera – Satna 765 kV line	765 kV, 330 MVA SLR along with switching eqpts. – 1 no (3 x 110 MVA) [110 MVA single phase reactor unit for bus reactor to be used as spare for line reactor too]

#LILO of both circuits of Bina - Datiya 220 kV D/c line at Karera, Extension of LILO portion of 220 kV Datiya - Bina line for Pichhore 220 kV upto Karera & Karera - Seondha 220 kV D/c line

The subject transmission system was approved in the 11th NCT meeting held on 28.12.2022 and 17.01.2023 with an estimated cost of Rs. 1181 Crore.

Implementation time-frame: 24 months from date of allocation to implementing agency.

Under Intra-state (MPPTCL):

- LILO of both circuit Bina - Datiya 220kV line at Karera
- Extention of LILO portion of Datiya 220kV- Bina 400kV line for Pichhore 220kV upto Karera so as to form Karera – Pichhore 220kV D/c line
- Upgradation 132kV Seondha on 220kV with 2x200MVA,220/132kV ICT
- Karera 765kV S/s - Seondha 220kV(U/G) D/C 220kV line
- 132kV Seondha 220kV - Indergarh DCSS line

Implementation time-frame: Matching with ISTS scheme

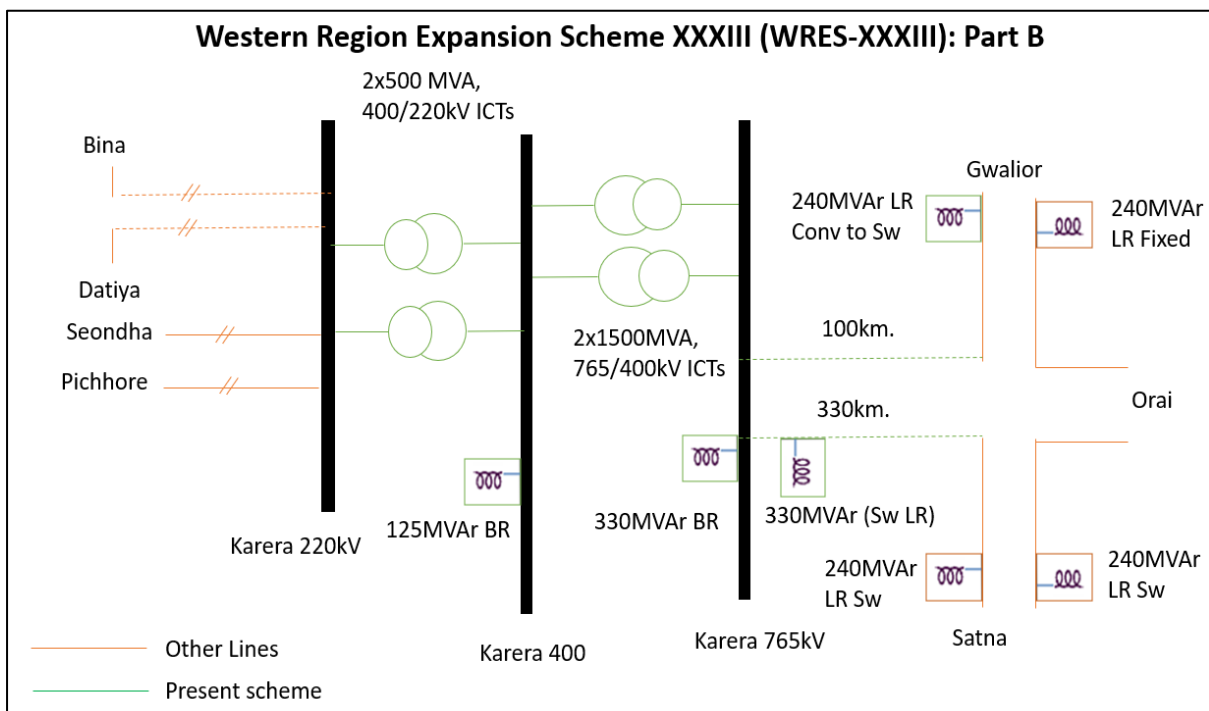

Figure 5-10: Western Region Expansion Scheme XXXIII: Part B

c) Western Region Expansion Scheme XXXIII (WRES-XXXIII): Part B1

With the LILO of Satna-Gwalior 765 kV S/c line at Karera, the degree of compensation of transmission elements have been changed viz-a-viz earlier configuration. Line reactor at Gwalior end in respect of Satna-Gwalior is originally fixed in nature, to cope up with the changed degree of compensation, the fixed line reactor is required to be converted to switchable (with NGR bypass arrangement) with implementation of Inter-tripping scheme.

Detailed scope of the scheme is as under:

Sl. No.	Scope of the Transmission Scheme	Capacity /km
1.	Conversion of 1x240 MVA, 765 kV Fixed line reactor at Gwalior end to Switchable line reactor (with NGR bypass arrangement) along with implementation of Inter-tripping scheme (for tripping of the switchable shunt reactor at Gwalior end along with the main line breaker)	<ul style="list-style-type: none"> Switching equipment for 765 kV line reactor (with NGR bypass arrangement) – 1 no. Implementation of inter-tripping scheme for the switchable shunt reactor at Gwalior end
Total Estimated Cost		Rs. 19 Crore

Implementation timeframe: In matching timeframe of Western Region Expansion Scheme XXXIII (WRES-XXXIII): Part B

d) Western Region Expansion Scheme XXXIII (WRES-XXXIII): Part C

M/s Rewa Ultra Mega Solar Limited (RUMSL) is in the process of establishing 950MW solar project in Bijawar area whereas M/s NTPC is also in the process of establishing 630MW solar project in Barethi/Chhatarpur area which includes forest stretch between Bijawar and Chhatarpur. Chhatarpur PS is proposed to be established in Bijawar area near to RUMSL solar site. The proposed Ishanagar (New) S/s shall be used to cater to the proposed Green hydrogen plant in nearby area, loads in Chhatarpur, Tikamgarh & Jatara areas and also for interconnection of 6300MW NTPC Barethi Solar Plant (located ~30-40km. from Ishanagar).

Detailed scope of the scheme is as under:

Sl.	Scope of the Transmission Scheme	Capacity /km
1.	Establishment of 765/400 kV, 2x1500 MVA ICTs and 400/220 kV, 2x500 MVA ICTs at Ishanagar (New) along with 1x330 MVA, 765 kV & 1x125 MVA, 420 kV bus reactor Future provisions: Space for <ul style="list-style-type: none"> ➤ 765/400 kV ICT along with bays- 4 no. ➤ 765 kV line bays along with switchable line reactors – 8 nos. ➤ 765 kV Bus Reactor along with bay: 3 no. ➤ 765 kV Sectionalizer: 1 set 	765/400 kV, 1500 MVA ICT – 2 nos. (7x500 MVA 1-phase units including one spare unit) 400/220 kV, 500 MVA ICT – 2 nos. 765 kV ICT bays – 2 nos. 400 kV ICT bays – 4 nos. 220 kV ICT bays – 2 nos. 765 kV Line bays – 2 nos. 330 MVA, 765 kV Bus Reactor – 1 no. (4x 110 MVA including one spare unit)

Sl.	Scope of the Transmission Scheme	Capacity /km
	<ul style="list-style-type: none"> ➤ 400 kV line bays along with switchable line reactor – 10 nos. ➤ 400/220 kV ICT along with bays -7 nos. ➤ 400 kV Bus Reactor along with bay: 3 no. ➤ 400 kV Sectionalization bay: 1- set ➤ 220 kV line bays: 12nos. ➤ 220 kV Sectionalization bay: 2 sets ➤ 220 kV BC and TBC: 3 nos. 	<p>125 MVAr, 420 kV Bus reactor – 1 no.</p> <p>765 kV Bus reactor bay: 1 no.</p> <p>400 kV Bus reactor bay: 1 no.</p> <p>220 kV Bus coupler bay- 1 no.</p> <p>220 kV Transfer Bus Coupler (TBC) bay - 1 no.</p> <p>220 kV line bays – 6nos.</p> <p>(for 220 kV lines to be implemented by MPPTCL#)</p>
2.	LILO of one circuit of Jabalpur - Orail 765 kV D/c line at Ishanagar 765 kV S/s (New)	LILO length – 5 km.

Note: #220 kV Ishanagar 765/400/220 kV - Jatara 220 kV D/C line and LILO of Chhatarpur – Tikamgarh 220 kV 2xS/c line at 765/400/220 kV Ishanagar (Chhatarpur – Tikamgarh 220 kV 2nd ckt is currently under implementation)

The subject transmission system was approved in the 11th NCT meeting held on 28.12.2022 and 17.01.2023 with an estimated cost of Rs. 556 Crore

Implementation time-frame: 24 months from date of allocation to implementing agency.

Under Intra-State (MPPTCL):

- Establishment of 220/132kV, 2x200MVA ICT & 132/33kV 2x50MVA ICT at Jatara 220kV S/s
- 220kV Ishanagar 765/400/220kV - Jatara 220kV D/C line
- 2nd circuiting of Chhatarpur – Tikamgarh 220kV DCSS line
- LILO of both circuit of Chhatarpur – Tikamgarh 220kV DCDS line at 765/400/220kV Ishanagar
- 132kV Jatara 220kV - Jatara 132kV D/C line (With High Capacity Conductor)
- 132kV Jatara 220kV - Nowgaon 132kV D/C line
- 2nd circuiting of Jatara 132kV - Prithvipur DCSS line
- 2nd circuiting of Jatara 132kV - Tikamgarh DCSS line

Implementation time-frame: Matching with ISTS scheme

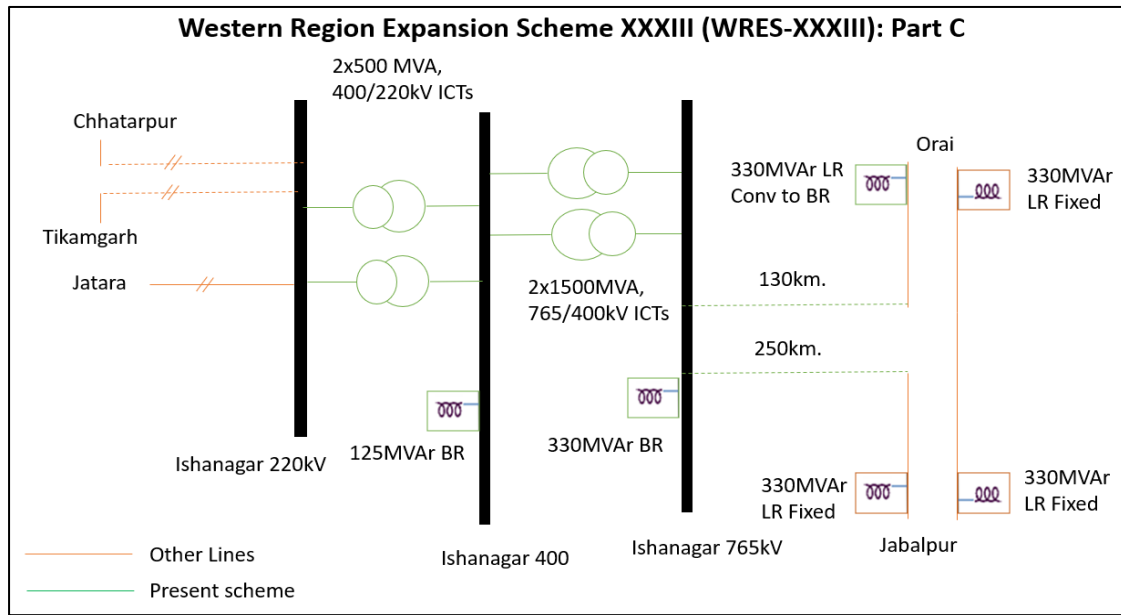

Figure 5-11: Western Region Expansion Scheme XXXIII: Part C

e) Western Region Expansion Scheme XXXIII (WRES-XXXIII): Part C1

With the LILO of one circuit of Jabalpur - Orai 765 kV D/c line at Ishanagar 765 kV S/s (New), the degree of compensation of new transmission element did not necessitate installation of fixed shunt reactors. Accordingly, the 1x330 MVAR, 765 kV Fixed line reactor at Orai end of Ishanagar – Orai 765 kV line (formed after LILO at Sl. 2) shall be converted to Bus reactor at Orai S/s

Detailed scope of the scheme is as under:

Sl. No.	Scope of the Transmission Scheme	Capacity /km
1.	Conversion of 1x330 MVAR, 765 kV Fixed line reactor at Orai end of Ishanagar – Orai 765 kV line (formed after LILO at Sl. 2) to Bus reactor at Orai S/s	<ul style="list-style-type: none"> Shifting of 330 MVAR, 765 kV Line reactor of Orai-Jabalpur line at Orai end and installing the same as Bus Reactor in existing future bay at Orai

Estimated Cost: Rs. 0.5 Crore

Implementation timeframe: In matching timeframe of Western Region Expansion Scheme XXXIII (WRES-XXXIII): Part C.

f) Western Region Expansion Scheme XXXIII (WRES-XXXIII): Part D

The 400/220kV, (2X315)+(1X500) ICTs at Satna (PG) along with downstream network i.e., Satna (PG)-Satna(MP) 220kV 3XS/c lines are found to be heavily loaded and N-1 non compliant in present time-frame. The subject scheme has been envisaged to take care of above overloading issues at Satna(PG) S/s.

Detailed scope of the scheme is as under:

Sl. No.	Scope of the Transmission Scheme	Capacity /km	Implementation Timeframe
1.	Installation of 1x500 MVA, 400/220 kV ICT (4 th) along with associated ICT bays at Satna(PG)	<ul style="list-style-type: none"> 400/220 kV, 500 MVA ICT – 1 no. 400 kV ICT bay – 1 no. 220 kV ICT bay – 1 no. (includes 220kV Cable interconnection for 220kV side of ICT) 	18 months from the issue of OM by CTUIL
2.	2 No. of 220kV line bays at Satna for LILO of Satna 220kV - Maihar 220kV line at Satna (PG) S/s	220kV line bay – 2 nos.	
Total Estimated Cost:			INR 77.52 Crore

The above scheme was approved by CTU vide OM dated 28/11/2022, with POWERGRID as implementing agency.

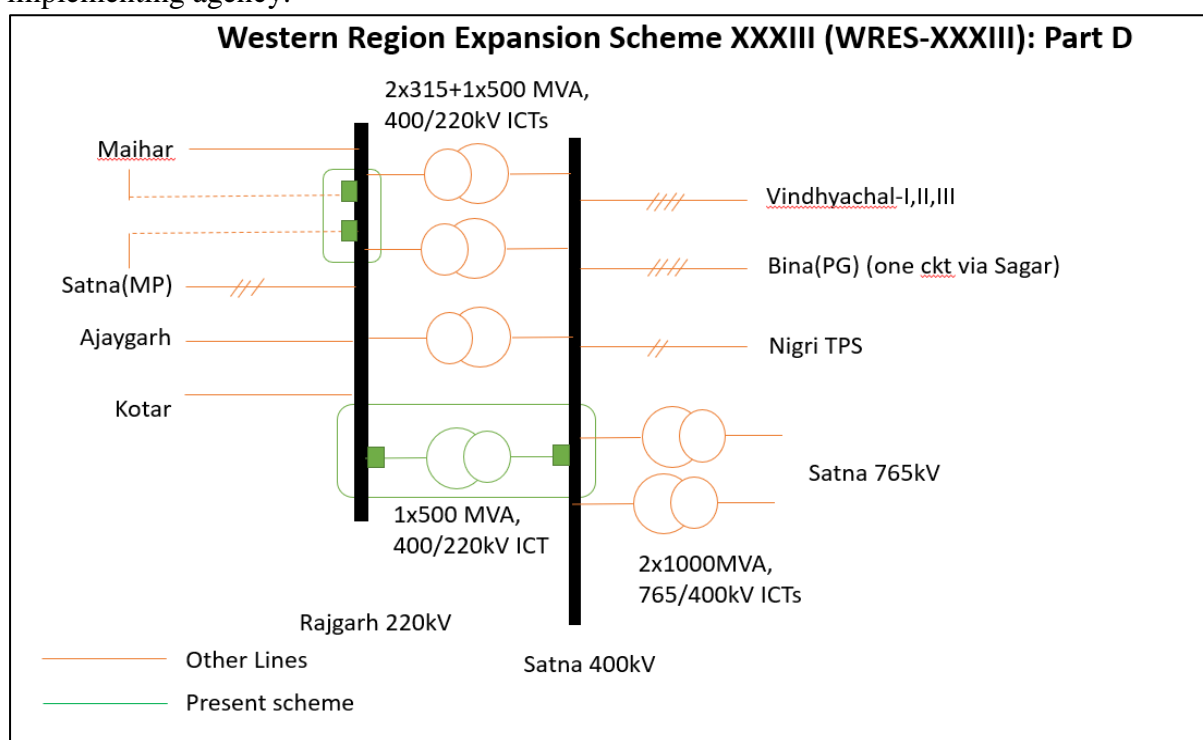

Figure 5-12: Western Region Expansion Scheme XXXIII: Part D

g) Transmission scheme for evacuation of power from Neemuch 2GW WEZ

In order to achieve the commitment made in terms of Nationally Determined Contributions (NDCs), as one of the significant steps, India has pledged to increase the non-fossil fuel energy capacity to 500 GW by 2030. This is a national mission as a part of the country's energy transition goal.

Further, out of 181.5GW REZ, SECI vide letter dated 23.06.2022 has informed that as a first step to provide RTC Power (with wind, solar & storage components), they have identified certain locations with high solar & wind potential where work on RE evacuation system may be taken up immediately. 2GW Wind Potential at Neemuch is one such prioritized RE Zone. As per feedback of SECI, the location of Pooling station for evacuation of 2GW WEZ in Neemuch was finalised as Mandsaur. The present scheme shall cater to evacuation of power from Neemuch 2GW WEZ.

Detailed scope of the scheme is as under:

Sl. No.	Scope of the Transmission Scheme	Capacity/km
1.	Creation of 400kV & 220 kV levels at Mandsaur PS through installation of 3x1500MVA, 765/400kV and 5x500MVA, 400/220kV ICTs^	765/400kV, 1500MVA ICT – 3 500 MVA, 765/400 kV Spare ICT-1 400/220 kV, 500 MVA ICT – 5 (3 nos. on 220kV bus section-1 & 2 nos. on 220kV bus section-2) 765 kV ICT bays – 3 400 kV ICT bays – 8 125 MVAR 420 kV bus reactor-2 400 kV reactor bay- 2 220kV ICT bays - 5 220 kV line bays – 7 (4 nos. on bus section-1 and 3 nos. on bus section-2) 220kV Bus Sectionaliser – 1 set 220kV TBC bay – 2 no. 220kV BC bay – 2 no.

^Considering 1x500MVA ICT for N-1 contingency

Estimated Cost: Rs. 667 Cr.

Implementation Time-frame: 24 months from date of allocation to implementing agency

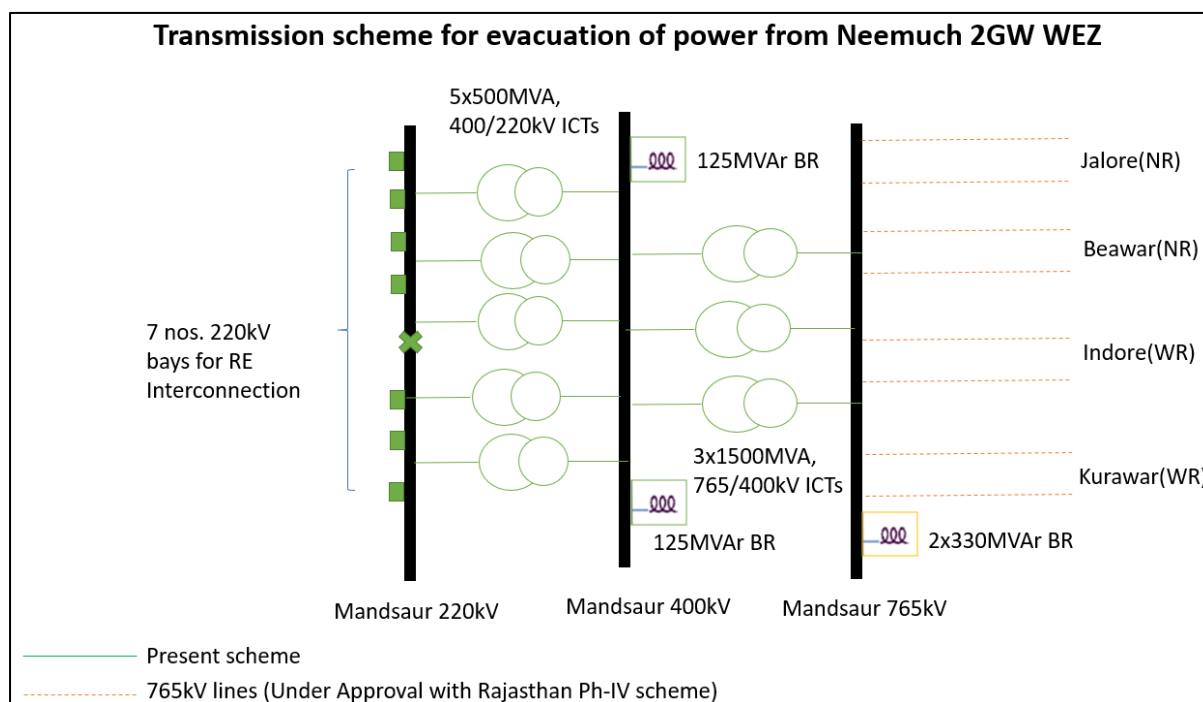

Figure 5-13: Transmission scheme for evacuation of power from Neemuch WEZ

h) Transmission System for Evacuation of Power from RE Projects in Rajgarh 1000 MW SEZ in Madhya Pradesh - Phase-II

The Transmission System for 2.5GW REZ at Rajgarh(MP) has been evolved as part of 66.5GW REZ in two phases:

- Ph-I of 1.5 GW: The scheme involves establishment of Pachora PS 3x500MVA, 400/220kV ICTs & Pachora – Bhopal 400kV D/c line (under implementation with SCoD of 30.11.2023) (out of which generation of 1GW of Agar / Shajapur Solar Parks has been identified)
- Ph-II of 1 GW: As agreed in 4th NCT, the scheme involved augmentation of transformation capacity at Pachora PS by 2x500MVA, 400/220kV ICTs (4th & 5th) & Pachora – Shujalpur 400kV D/c line and was required to be implemented with RE beyond 1.5GW at Pachora PS.

Meeting was held on 01.12.2022 amongst CEA, CTUIL, MPPTCL and GRID-INDIA for finalizing above scheme, wherein, augmentation of transformation capacity at Pachora PS by 2x500MVA, 400/220kV ICTs (4th & 5th) & Pachora – Ujjain 400kV D/c line was agreed for evacuation of 1GW power from Pachora PS under Ph-II. (Beyond 1.5GW). The matter was subsequently deliberated in the 13th CMETS-WR meeting held on 08.12.2022 wherein the revised scheme for evacuation of Power from RE Projects in Rajgarh SEZ in Madhya Pradesh under Phase-II (1000 MW) was agreed. The scheme was also deliberated in 11th NCT held on 28.12.2022 & 17.01.2023 and 12th NCT meeting held on 24.03.2023, wherein, it was decided that to fulfill 'N-1' reliability criteria at Pachora PS, 1x500 MVA (6th ICT) is also required. Detailed scope of the scheme is as under:

Sl. No.	Scope of the Transmission Scheme	Capacity/km
1.	400/220 kV, 3x500 MVA ICT augmentation (4 th 5 th & 6 th) at Pachora PS	400/220 kV, 500 MVA ICT – 3 400 kV ICT bays – 3 220 kV ICT bays – 3 400 kV line bays – 2 220 kV line bays – 4 (to be taken up as per applications received) 400kV Bus Sectionaliser – 1 set 220kV Bus Sectionaliser – 1 set 220kV TBC bay – 1 no. 220kV BC bay – 1 no.
2.	Pachora PS – Ujjain (MPPTCL) 400kV D/c line (Quad ACSR/AAAC/AL59 Moose equivalent)	Length – 60 km
3.	2 no. of 400 kV line bays at Ujjain (MPPTCL) for Pachora – Ujjain 400kV D/c line	400kV line bays – 2

Note:

(i) MPPTCL to provide space for 2 no. of 400 kV line bays at Ujjain for termination of Pachora PS – Ujjain 400 kV D/c line.

Implementation time-frame: 24 months from date of allocation to implementing agency

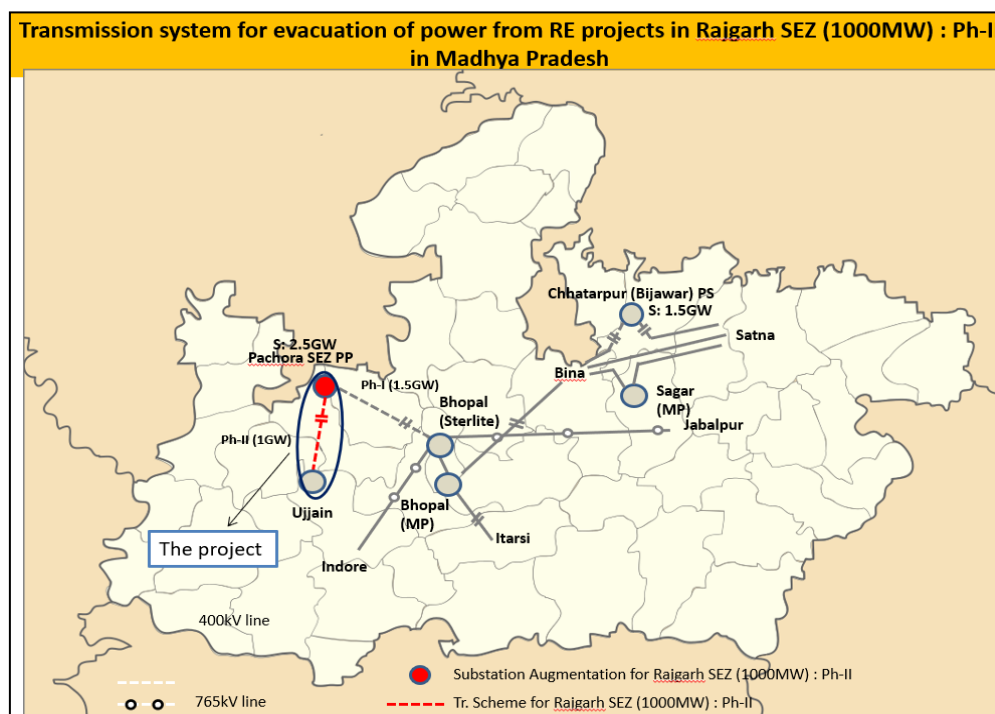

Figure 5-14: Transmission System for Rajgarh SEZ Phase-II

i) Transmission System for providing connectivity to M/s VEH Jayin Renewables Pvt. Ltd. at Rajgarh (PG) S/s

M/s VEH Jayin Renewables Pvt. Ltd applied for stage-II connectivity for its RE power plant at Rajgarh (PG) S/s. Based on receipt of Stage-II connectivity from VJRPL at Rajgarh(PG) S/s and subsequent studies, it was observed that capacity that can be evacuated from 220kV level of Rajgarh S/s is limited to ~300MW due to issue of overloading of downstream system. To overcome the above issue, the possibility of sectionalization of 220kV bus of Rajgarh S/s along with installation of 3rd 400/220kV ICT at Rajgarh S/s (on the sectionalized bus) in order to enable direct RE injection at 400kV level was taken up with POWERGRID. Based on deliberations and studies, the subject transmission scheme was evolved for providing connectivity to M/s VEH Jayin Renewables Pvt. Ltd. (190.2MW) at Rajgarh (PG) and to enable evacuation of power from the project.

Detail scope of the scheme:

Sl. No.	Scope of the Transmission Scheme	Capacity /km	Implementation Timeframe
1.	220kV bus extension (GIS) of Rajgarh 400/220 kV (PG) S/s along with 220kV Bus Coupler bay for extended bus	• Bus Extension along with 220kV Bus coupler bay- 1 no. using GIS	21 months from the issue of OM by CTUIL
2.	220kV bus sectionaliser bay (GIS) between existing & extended 220 kV bus of Rajgarh S/s	• 220kV Bus Sectionaliser – 1 set (GIS)	
3.	220kV GIS line bay at Rajgarh 400/220 kV (PG) S/s (on extended bus) for RE interconnection	• 220kV line bay: 1 no. (GIS) along with 220kV Bus Duct for Bus Extension (AIS to GIS building)	
Total Estimated Cost:			INR 29.33 Crore

The above scheme was approved by CTU vide OM dated 28/11/2022, with POWERGRID as implementing agency.

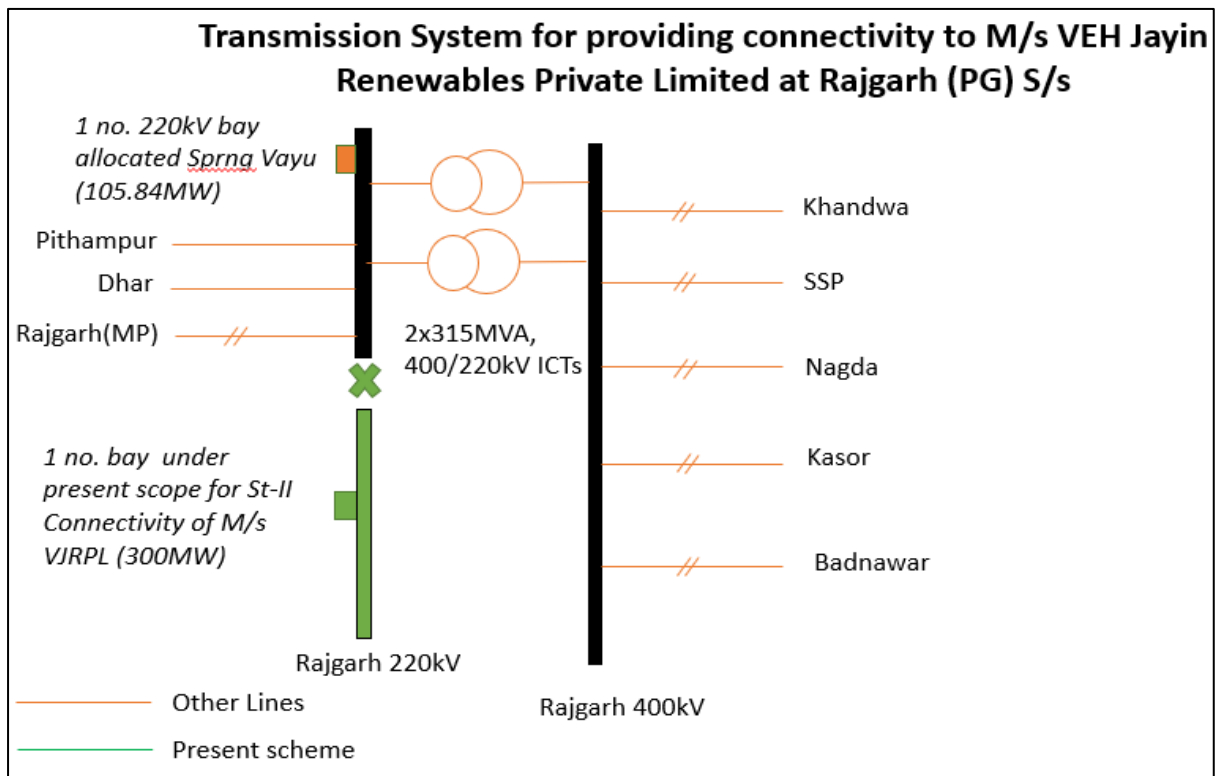

Figure 5-15: Transmission System for VEH Jayin at Rajgarh (PG) S/s

5.5 Measures taken for mitigation of the issues of previous Rolling Plans

5.5.1 Measures for controlling overloading of Transmission lines and ICTs

Transmission lines:

In the analysis carried out in ISTS Rolling Plan 2027-28 timeframe (Interim Report), 5 nos. of 765 kV lines and 8 Nos. of 400kV lines were observed to be having critical loading in base case as well as Contingency scenario. To relieve overloading of KPS1-Bhuj 765kV D/c line, KPS1 (GIS)– Bhuj PS 765 kV 2nd D/C line has been planned under Phase-IV (7GW) scheme. Further, to relieve overloading of Navsari (New)- Padghe 765kV D/c line & Navsari (New)- Vataman 765kV 765kV D/c line, additional corridors which includes Vadodara – Navsari(New) 765kV D/c line, Navsari(New) – Boisar-II 765kV D/c line & LILO of Navsari(New) – Padghe(PG) 765kV D/c line at Boisar-II have been planned which has reduced loadings on the above lines.

Further, for reducing the overloading on TAPS- Velgaon 400kV D/c line, LILO of Tarapur/Velgaon – Padghe (M) 400kV D/c line at Kudus(M) S/s has been planned in following manner so as to form Padghe(PG)(GIS) – Padghe(M) 400kV D/c line and Tarapur/Velgaon - Kudus(M) 400kV D/c line. For balance transmission lines in other states (ISTS/STUs), suitable strengthening scheme will be identified in next rolling plan.

Inter-connecting Transformers (ICTs):

In the analysis carried out in ISTS Rolling Plan 2027-28 timeframe (Interim Report), 13 nos. of ICTs at ISTS substations & 8 nos. of ICTs at STU substations were observed to be having critical loading in base case as well as Contingency scenario. To control overloading on

Navsari (New) ICTs, augmentation of transformation capacity at Navsari (New) 765/400kV by 1x1500MVA (ICT-IV) has been planned in addition to additional outlets from Navsari (New) mentioned above. To control overloading on Boisar 400/220kV ICTs, establishment of 765/400/220kV Boisar-II (GIS) S/s (3x1500, 765/400kV & 2x500MVA, 400/220kV) alongwith Navsari(New) – Boisar-II 765kV D/c line, LILO of Navsari(New) – Padghe(PG) 765kV D/c line at Boisar-II & Boisar-II – Velgaon(MH) 400kV D/c line has been planned.

Further, for relieving overloading on Padghe(MH) ICTs, bus splitting at both 400kV & 220kV levels alongwith augmentation of transformation capacity at Padghe (MH) by 400/220 kV, 2x500 MVA ICTs has been planned by MSETCL.

In addition to above, STUs may take necessary action for ICTs at STU S/s by load diversion or capacity augmentations.

5.5.2 Measures for controlling Short Circuit

As per the short circuit analysis carried out in ISTS Rolling Plan 2027-28 timeframe (Interim Report), Short circuit level was calculated for all 765kV and 400 kV buses of Western Region and it was noted that 4 nos. of 765kV substations and 24 nos of 400kV substations in WR were having fault level more than designed capacity.

Issue of high fault levels at C'pur-I/C'pur-II/A'bad-I/A'bad-II/A'bad-III was deliberated in the 10th CMETS-WR meeting held on 30.08.2022 & 13th CMETS-WR meeting held on 22.12.2022, wherein, it was informed that high fault levels are seen at the given substations primarily because of very short lines between C'pur-I & C'pur-II and between A'bad-I, A'bad-II & A'bad-III. It was decided that MSETCL shall check ratings of breakers at above substations and possibility of upgradation of equipments from 40kA to 50kA (in earlier cases, several old equipments were already found to be rated to 50kA) may be ascertained. Otherwise, MSETCL may explore possibility of reducing fault levels at above substations through suitable splitting / bypassing arrangement with or without series bus / line reactors.

Scheme to control high fault level at Parli(PG) is already under implementation and for Padghe (PG), Padhhe (M), Kudus & Kalwa S/s the schemes have been evolved and is pending confirmation from MSETCL for feasibility. Studies to limit high short circuit on remaining ISTS S/s would be carried out and taken up in next rolling plan. Further, STUs/Gen developer are also required to take necessary actions such as bus splitting, bypassing of lines, fault limiting reactors etc to resolve the issue of high fault level at their buses.

5.5.3 Measures for controlling over-voltage

As per the voltage analysis carried out in ISTS Rolling Plan 2027-28 timeframe (Interim Report), 765 kV (1 no.) and 400 kV (3 nos.) buses were having issue of high voltage (voltage more than 1.05 pu). Further, 400 kV (10 nos.) buses were having issue of low voltage (voltage less than 0.95 pu).

High voltages were observed at Wardha, Aurangabad, Warora buses during during Evening & Offpeak hours due to less loading in 765kV and 400kV lines emanating from these substations. Wardha-Aurangabad 765kV 2xD/c lines are planned to be LILOed at Akola-III HVDC which has reduced the line length of above lines and thereby has improved the voltage profile of these

areas. Further, adequate reactive compensation has been also been planned at Akola-III bus to control high voltage issues.

Low voltages were observed in Western part of Maharashtra (400kV Kharghar, Kalwa, Vikhroli, Padghe, Chakan buses) and 400kV Hazira bus. The low voltages in Western part of Maharashtra is observed due to concentration of load in these areas. In this regard, new ISTS substations in Maharashtra at Boisar-II, Pune-III & Akola-III has been planned under Transmission System for Evacuation of Power from potential renewable energy zone in Khavda area of Gujarat. ± 300MVAR STATCOM with 3x125 MVAR MSC, 1x125 MVAR MSR at 400kV level of Boisar-II & Navasri (New) has also been planned under the above scheme. Further, LILO of one ckt of Lonikand-I – Jejuri 400 kV D/c line at Pune (PG)(GIS) with high capacity conductor along with reconductoring of Lonikand-I Jejuri line section and LILO of Hinjewadi-Koyna 400kV line at Pune-III(GIS) S/s has also been planned which has helped in improving the voltage of Western Maharashtra S/s (Jejuri, Hinjewadi, Koyna & Lonikand).

Further, STUs have also been impressed upon to install suitable capacitor bank at lower voltages to control the low voltages problems.

5.5.4 Mitigation of operational issues faced by JP Bina due to NHPTL testing

A meeting was held on 24.11.2022 amongst CEA, CTUIL, JP Bina, GRID-INDIA, MPPTCL/MPSLDC & POWERGRID to discuss the operational issues faced by JP Bina due to NHPTL testing. Following were decided w.r.t. permanent arrangement in the meeting:

- As a permanent arrangement, in order to mitigate the oscillations, scheme comprising of formation of JP Bina – Bhopal 400 kV two nos. lines [2nd line formed by bypassing at 2 substations i.e.: JP Bina to Bina (MP) line by bypassing at Bina (PG) and then JP Bina to Bhopal (MP) line by bypassing at Bina (MP)] was agreed. (refer diagram)

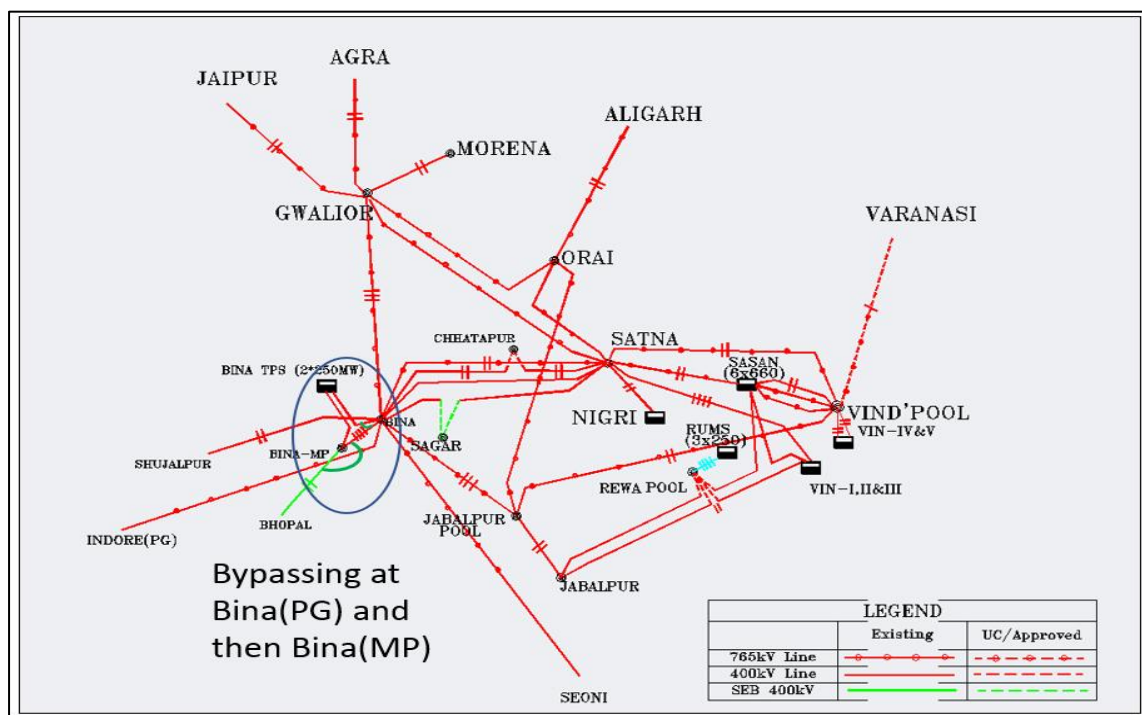

Figure 5-16: Network interconnection of JP Bina

- CTUIL would take the feedback from POWERGRID and MPPTCL for the above bypassing at Bina (PG) and Bina (MP) respectively to ascertain if the bypassing can be done by opening the main breakers of the same diameter (after shifting of the lines to the corresponding diameter). Based on the feedback, the suitable arrangement would be evolved and implemented.
- Further, as an alternative, formation of JP Bina – Sagar (MP) 400 kV direct line by bypassing at Bina (PG) was also deliberated. Accordingly, feedback from POWERGRID is required that whether the bypassing at Bina (PG) end can be done by opening the main breakers of the same diameter (i.e. swapping of Satna-2 line with SATNA-3 LILO-SAGAR line so that JP Bina line & Sagar line is in the same diameter) or the same may be carried out by bypassing at the outskirts of Bina (PG) S/s.

Details of studies carried out along with observations are given below:

Case 1: Formation of JP Bina – Bhopal 400 kV direct line by bypassing at Bina (MP) (after flat run till 2 seconds) and thereafter, formation of JP Bina – Satna (PG) 400 kV direct line by bypassing at Bina (PG) at 5 seconds.

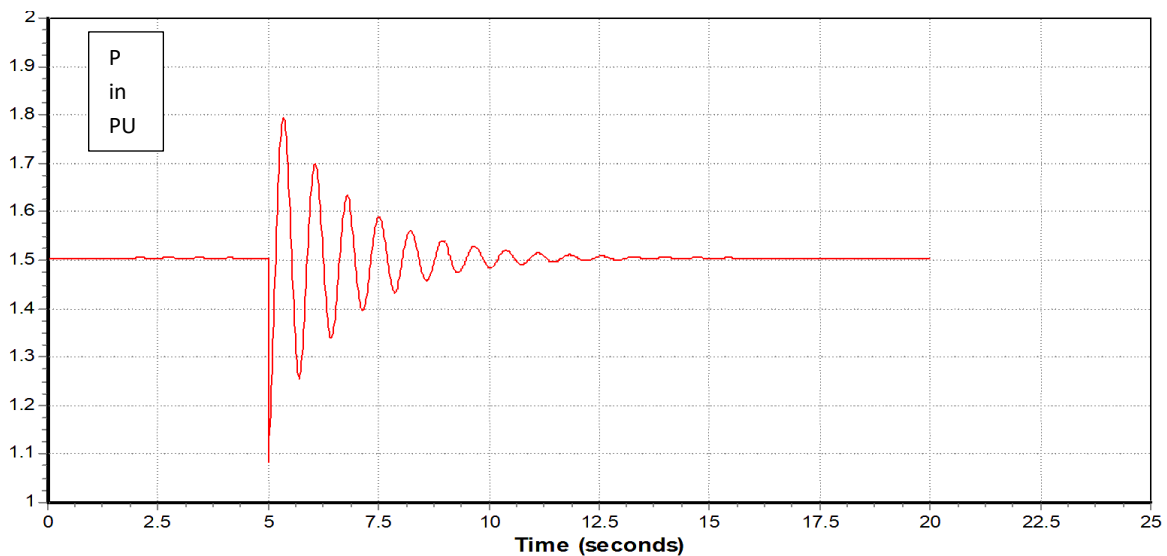

Figure 5-17: Power Output of Jaypee Bina for Case-1

Around 29 MW of load fluctuation (3rd peak to peak amplitude) is observed during formation of JP Bina – Satna (PG) 400 kV direct line by bypassing at Bina (PG) with damping within 7-8 seconds.

Case 2: Formation of JP Bina – Satna (PG) 400 kV direct line by bypassing at Bina (PG) (after flat run till 2 seconds) and thereafter, formation of JP Bina – Bhopal 400 kV direct line by bypassing at Bina (MP) at 5 seconds [i.e. With sequence of operation reversed vide bypassing first at Bina (PG) and then at Bina (MP)]

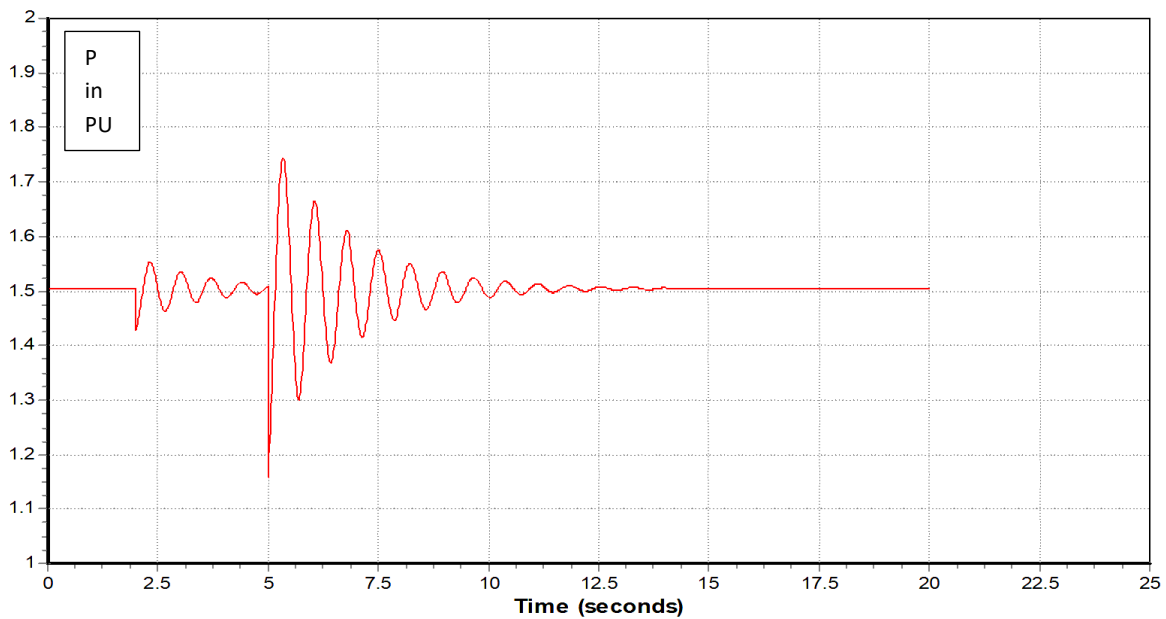

Figure 5-18: Power Output of Jaypee Bina for Case-2

Around 3 MW of load fluctuation (3rd peak to peak amplitude) is observed during formation of JP Bina – Satna (PG) 400 kV direct line by bypassing at Bina (PG) and around 25 MW of load fluctuation (3rd peak to peak amplitude) is observed during formation of JP Bina – Bhopal 400 kV direct line by bypassing at Bina (MP) with damping within 7-8 seconds. (i.e. oscillations reduce by about 4-5MW w.r.t Case-1)

Case 3: Formation of JP Bina – Bhopal 400 kV direct line by bypassing at Bina (MP) after (flat run till 2 seconds) and thereafter, formation of JP Bina – Sagar (MP) 400 kV direct line by bypassing at Bina (PG) at 5 seconds.

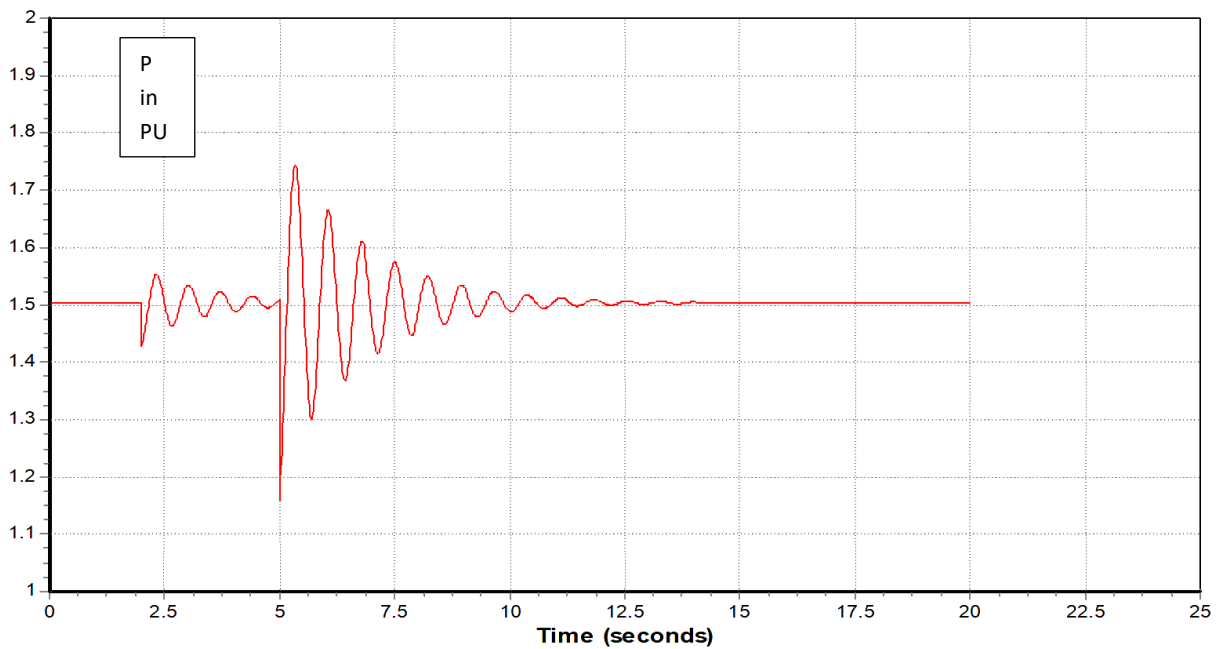

Figure 5-19: Power Output of Jaypee Bina for Case-3

Around 7 MW of load fluctuation (3rd peak to peak amplitude) is observed during formation of JP Bina – Sagar (MP) 400 kV direct line by bypassing at Bina (PG) (i.e. oscillations reduce by about 22MW w.r.t Case-1).

Case4: Formation of JP Bina – Bhopal 400 kV two nos. lines after (flat run till 5 seconds) [2nd line formed by two bypassing: JP Bina to Bina (MP) line by bypassing at Bina (PG) and then formation of JP Bina to Bhopal (MP) line by bypassing at Bina (MP)]

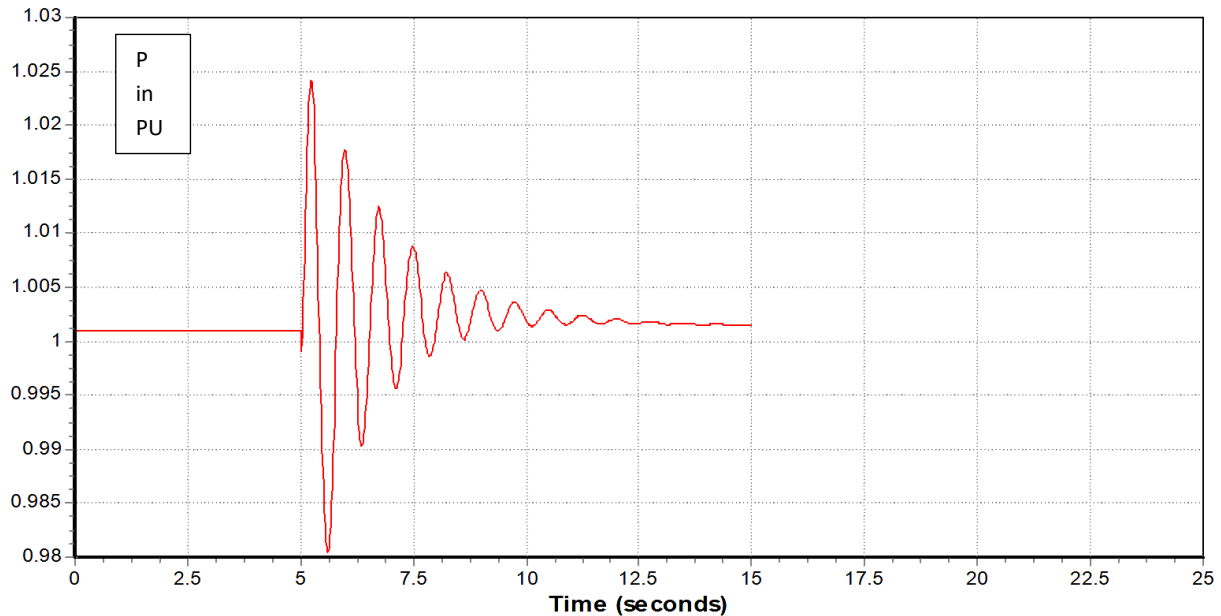

Figure 5-20: Power Output of Jaypee Bina for Case-4

Around 2 MW of load fluctuation (3rd peak to peak amplitude) is observed during formation of JP Bina – Bhopal 400 kV two nos. lines (i.e. oscillations reduce by about 27MW w.r.t Case-1)

5.6 System Study Results and Analysis

Based on the load-generation scenarios as elaborated in section 1.3, various system studies have been carried out in PSSE. Planned/ Under implementation Transmission system that are expected to be commissioned in 2027-28 timeframe are considered for conducting these studies. Results of these studies were analysed and the same are deliberated below-

5.6.1 Power Flow Studies

The base case file was prepared for 2027-28 timeframe. The study results are detailed in subsequent sections.

5.6.2 Voltage Analysis

Per Unit voltages of all 765 kV and 400 kV buses were monitored in all the nine scenarios. Maximum and minimum voltage of each bus was identified from nine voltages available in nine number of scenarios. Following 765kV & 400kV buses were observed to be having voltage more than 1.05 pu and less than 0.95pu are tabulated below at **Table 5-7:**

Table 5-7: Buses having more than 1.05 pu Voltage in WR

Sl. No.	Bus Name	Voltage Level	Owner	Max	Scenario
Overvoltage					
1	Shivlakha PS	400	STU	1.07	All Scenarios
2	Bhachaunda	400	STU	1.06	4
3	Keshod	400	STU	1.05	8
4	Jaigad II	400	STU	1.11	1,4
5	Dolvi	400	STU	1.10	1,4
6	Bhusawal-I	400	STU	1.06	3
7	Bhusawal-II	400	STU	1.05	3
8	Malegaon	400	STU	1.05	3

In Gujarat, high voltages have been observed at Shivlakha, Bhachaunda & Keshod substations. In Maharashtra, high voltages have been observed at Parli (M), Bhusawal-I & II substations. Adequate reactive compensation at above buses may be planned by respective STUs to control high voltage issues.

Further, Jaigad-II and Dolvi are weak buses having low short circuit strength. Accordingly, both high voltage and low voltages are observed in accordance with generation dispatches. In addition to above, low voltages are also observed in Western part of Maharashtra (400kV Kharghar, Kalwa, Vikhroli, Padghe, Chakan buses). The low voltages in Western part of Maharashtra is observed due to concentration of load in these areas. Suitable capacitor banks may be installed by STUs at lower voltages to control the low voltages.

5.6.3 Contingency Analysis

Contingency analysis has been performed on all the 765 kV & 400kV transmission lines, and 765/400 kV & 400/220 kV transformers to ascertain the loading levels under outage of any other 765 kV or 400 kV transmission element. Results of the analysis are discussed below:

a) Transmission Lines

List of 765kV ISTS lines loaded beyond 3500MW under N-1 contingency are summarized below at **Table 5-8**:

Table 5-8: 765kV ISTS Transmission lines not meeting N-1 Criteria in WR

Sl. No.	Name of the Line	Contingency	Scenario No.	Owner	Base case Loading	Loading under n-1	Rating	% Loading
1	Tamnar – Dharamjaigarh 765kV one line	Tamnar – Dharamjaigarh 765kV other line	2,5	ISTS	2368	3992	3500	114
2	Vadodara – Vataman 765kV one line	Vadodara – Vataman 765kV other line	4	ISTS	2553	3586	3500	102

Due to high generation in Chattisgarh, and low generation in West Bengal, high power is flowing on Tamnar – Dharamjaigarh-Ranchi-Mednipur 765kV D/c corridor. Suitable network

augmentation would be planned in consultation with respective STUs. In Gujarat, high loadings on Vataman - Vadodara 765kV D/c line is observed on account of high RE generation in Khavda, coupled with 2GW Off-shore Wind farm in Gujarat pooled at Vataman S/s under Phase-II of 181.5GW RE potential expected to be commissioned by Dec'27 as per CEA 500GW RE capacity report. However, transmission system for offshore would be finalised after discussions with concerned stakeholders and suitable augmentation would be evolved in consultation with stakeholders.

Further, 400kV ISTS/STU lines loaded beyond 100% of thermal rating under N-1 contingency are summarized below at **Table 5-9:**

Table 5-9: 400kV Transmission lines not meeting N-1 Criteria in WR

Sl. No.	Name of the Line	Contingency	Scenario No.	Owner	Base case Loading	Loading under N-1	% Loading	Rating
1	Khargar - Navi Mumbai 400kV line	Khargar - Padghe 400kV line one ckt	1,4,7	ISTS	361	1082	126	857
2	A'bad – I – A'bad – II 400kV D/c line one ckt	A'bad – I – A'bad – II 400kV D/c line other ckt	1,4	STU	544	1031	120	857
3	Datiya new - Morena SP 400kV D/c line one ckt	Datiya new - Morena SP 400kV D/c line other ckt	4,7	ISTS	1165	2323	106	2186

Reconductoring of Khargar - Navi Mumbai 400kV line may be done by MSETCL to mitigate the overloading issue. A'bad-I and A'bad-II substations are interconnected through very short lines and the issue to resolve overloading alongwith high short circuit issues at the above substations has been discussed in WR-CMETS meeting and adequate scheme would be evolved in consultaion with MSETCL. As per CEA 500GW RE capacity report, 2.5GW RE out of total 3.9GW potential at Morena under Ph-II which is expected by Dec'27 has been considered. Under the scheme, establishment of Morena PS alongwith Morena PS – South Gwalior (near Datiya) 400 kV D/c (quad moose) line has been planned for evacuation of 2.5GW RE power at Morena. For N-1 compliance, further interconnection in the form of Morena PS – Morena (TBCB) 400 kV D/c (quad) line would be planned for evacuation of potential beyond 2GW. However, transmission system for Morena would be finalised after discussions with concerned stakeholders.

b) Transformers

List of ISTS ICTs loaded beyond MVA rating under N-1 contingency are summarized below at **Table 5-10:**

Table 5-10: ISTS ICTs not meeting N-1 Criteria in WR

Sl. No.	Name of the Element	Scenario No.	Owner	Maximum Base Case Flow	Maximum Loading under N-1 of ICT	% Loading	Rating
1	400/220kV, 2X315 MVA Magarwada DD ICTs	1,2,4,5,6,7, 8	ISTS	206	420	133	315
2	765/400kV, 2X1500 MVA Indore ICTs	7	ISTS	1417	1699	113	1500
3	400/220kV, 2X315MVA Navi Mumbai ICTs	7	ISTS	275	324	103	315
4	400/220kV, 2x315MVA Aurangabad ICTs	7	ISTS	240	334	106	315
5	765/400kV, 2x1500MVA Aurangabad ICTs	1	ISTS	1137	1612	107	1500
6	400/220kV, (2X315)+(1X500) MVA Wardha ICTs	1,7	ISTS	273	384	122	315
7	400/220kV, 2x500MVA Datiya New ICTs	1,7	ISTS	473	737	147	500

In MP, high loading of ICTs at Indore (PG) is observed due to high RE injection from Neemuch PS alongwith NR RE injection. Further, high loading of ICTs at Datiya (New) is observed with integration of 2.5GW RE potential at Morena under 181.5GW REZ through Morena PS – Datiya (New) 400 kV D/c line under Ph-II. Adequate system augmentation at Datiya (New) & Indore (PG) would be finalised after discussions with concerned stakeholders.

In DD, high loading of ICTs at Magarwada is observed due to high RE integration in Gujarat coupled with high demand in Gujarat & DD and low self-generation in DD. The above RE power is also overloading Magarwada ICTs. Adequate system augmentation in consultation with GETCO/DD would be evolved.

In Maharashtra, high loading of ICTs at Wardha is observed due to high RE injection from proposed Wardha (2500MW) Solar park which has not been taken up as per inputs of SECI/MNRE. Further, Navi Mumbai & Aurangabad ICTs are also observed to be overloaded due to high demand in western part of Maharashtra and low self-generation. Import capability (ATC) constraints for Maharashtra have been reported by WRLDC and associated system augmentation in consultation with MSETCL would be evolved. In addition to above, Kallam 400/220kV, 4X500MVA ICTs are N-1 non compliant as the above substation was planned for evacuation of 2GW RE potential at Kallam in line with CEA 2013 planning criteria, which stipulates that ‘N-1’ criteria may not be applied to the immediate connectivity of wind/solar farms with the ISTS/Intra-STS grid.

List of STU ICTs loaded beyond MVA rating under N-1 contingency are summarized below at **Table 5-11:**

Table 5-11: STU ICTs not meeting N-1 Criteria in WR

Sl. No.	Name of the Element	Scenario No.	Owner	Maximum Base Case Flow	Maximum Loading under N-1 of ICT	% Loading	Rating
1	400/220kV, (2X315) + (1X500) MVA Nagothane ICTs	1,4,7	MSETCL	261	406	129	315
2	400/220kV, 2X315 MVA Mundra APL ICTs	2,3,5,6	APL	301	414	131	315
3	765/400kV, 2X1000 MVA Sipat ICTs	1,4	NTPC	820	1242	124	1000
4	400/220kV, (2X315) +(1X500) MVA Charanka ICTs	4,7	GETCO	207	327	104	315

From above, it is observed that ICT loadings i.r.o 1 no. of substation in Maharashtra, 2 no. in Gujarat, and 1 no. in Chhattisgarh are not complying with N-1 criteria in 2027-28 timeframe. Therefore, respective STUs/Owners are required to take advance action to mitigate this issue. Additional system strengthening in these areas such as planning additional feeds from ISTS, shifting of loads, ICT augmentation, increase in self generation, etc. may be required to feed the growing demand.

5.6.4 Short Circuit Analysis

Short circuit level was calculated for all 765 and 400 kV buses of Western Region and buses having fault level more than the 5% of design rating under various scenarios were identified. From analysis, it is emerged that there as 4 nos. of 765kV substations and 19 nos of 400kV substations in WR having fault level more than 5% of designed capacity. Owner wise distribution of these buses and scenarios in which these buses are crossing the shown below:

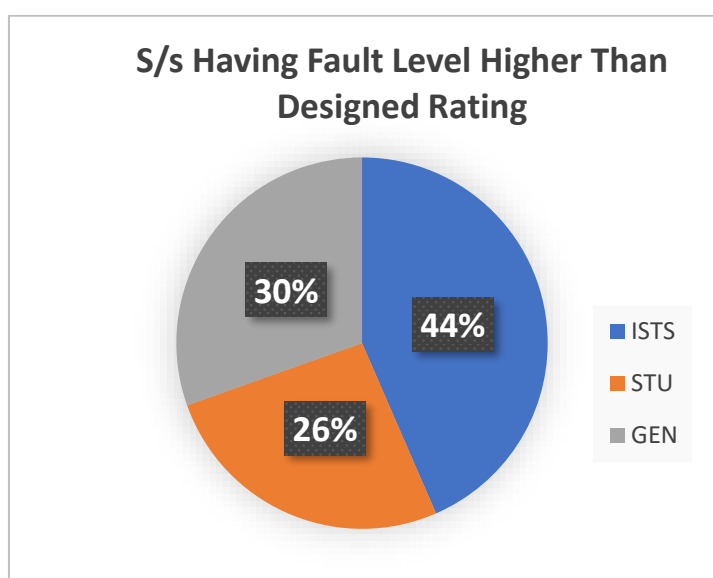

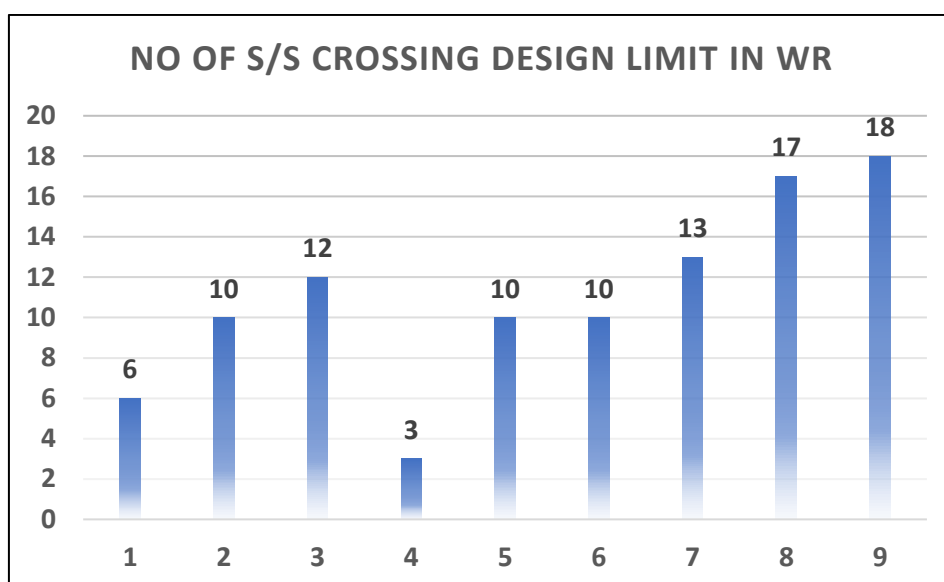

Figure 5-21: Substations crossing the design limit in WR at 400kV buses

Details of the ISTS buses exceeding design fault level by more than 5% are tabulated below at **Table 5-12:**

Table 5-12: ISTS Buses Exceeding Designed Fault Level in WR

Sl. No.	Substation Name	Scenario No.	Highest Fault level (kA)	Designed Rating (kA)
1	765kV Jabalpur Pool	8,9	53	50
2	765kV Wardha	2,3,5,6,7,8,9	44	40
3	765kV Bilaspur Pool	2,3,5,6,7,8,9	44	40
4	765kV Gwalior	2,3,6,8,9	43	40
5	400kV Vadodara	8,9	53	50
6	400kV Pune (GIS)	3,9	53	50
7	400kV Boisar	All	47	40
8	400kV Bilaspur Pool	2,3,5,6,7,8,9	47	40
9	400kV Bina	2,3,5,6,7,8,9	43	40
10	400kV Jabalpur	8,9	43	40

From the above, it can be seen that 10 nos. of buses i.e. 400kV & 765kV Bilaspur PS, 765kV Jabalpur PS, 765kV Wardha, 765kV Gwalior, 400kV Bina, 400kV Vadodara, 400kV Boisar, 400kV Pune (GIS) violates the design fault level by more than 5%. Studies shall be carried out to mitigate the same in consultation with various stakeholders of WR.

Further, following STU buses exceeding the substation design fault level by more than 5% under different scenarios are mentioned at **Table 5-13:**

Table 5-13: STU Buses Exceeding Designed Fault Level in WR

Sl. No.	Substation Name	State	Scenario No.	Highest Fault level (kA)	Designed Rating (kA)
1	400kV Nagda	MP	1,2,3,5,6,7,8,9	44	40
2	400kV Bina	MP	2,3,6,7,8,9	43	40
3	400kV Aurangabad-I	Maharashtra	2,3,5,6,7,8,9	45	40
4	400kV Aurangabad-II	Maharashtra	2,3,5,6,7,8,9	44	40
5	400kV Aurangabad-III	Maharashtra	3,9	43	40
6	400kV Soja	Gujarat	8,9	42	40

Following Generator buses exceeding the substation design fault level by more than 5% under different scenarios are mentioned at Table 5-14 below:

Table 5-14: Generator Buses Exceeding Designed Fault Level in WR

Sl. No.	Substation Name	State	Scenario No.	Highest Fault level (kA)	Designed Rating (kA)
1	400kV CGPL	Gujarat	1,2,3,5,6,7,8,9	46	40
2	Mundra-APL	Gujarat	8,9	42	40
3	400kV Jindal	Chhattisgarh	1,2,3,5,6,7,8,9	46	40
4	400kV Chandrapur-I	Maharashtra	7,8,9	46	40
5	400kV Chandrapur-II	Maharashtra	7,8,9	46	40
6	400kV Chandrapur SW	Maharashtra	7,8,9	44	40
7	400kV TAPS4	Maharashtra	All	48	40

With respect to high fault levels at C'pur-I/C'pur-II/A'bad-I/A'bad-II/A'bad-III, as discussed in the 10th CMETS-WR meeting held on 30.08.2022, high fault levels are seen at the above MSETCL substations primarily because of very short lines between C'pur-I & C'pur-II and between A'bad-I, A'bad-II & A'bad-III and presence of generators in close proximity. MSETCL shall check ratings of breakers at above substations and possibility of upgradation of equipments from 40kA to 50kA (in earlier cases, several old equipments were already found to be rated to 50kA). Otherwise, MSETCL may explore possibility of reducing fault levels at above substations through suitable splitting / bypassing arrangement with or without series bus / line reactors.

Further, STUs/Generators are required to take necessary actions such as bus splitting, bypassing of lines, fault limiting reactors etc to resolve the issue of high fault level at their buses.

Page intentionally left blank

Chapter 6: Southern Region

Southern Region is connected to Western and Eastern Regions through high capacity 765kV AC links, Back-to-Back HVDC and Bi-pole HVDC links. The thermal generating stations of Southern Region are predominantly concentrated in the States of Tamil Nadu, Karnataka, Andhra Pradesh and Telangana. The States of Tamil Nadu, Karnataka and Andhra Pradesh are rich in RE comprising of large scale Solar & Wind potential. Southern part of Karnataka (Bangalore), Kerala and Central part of Telangana (Hyderabad) has high demand and less internal generation. With the continuous increase in demand and limited conventional generation availability, Southern Region imports power from NEW Grid during peak demand period whereas it exports power to NEW Grid during high RE scenario / off peak demand period.

6.1 Power Supply Scenario as on Feb'23

As on Feb, 2023 total Installed Capacity (IC) of Southern Region was about 122 GW and the peak demand was about 61 GW. Southern Region has touched the maximum export of about 7 GW and maximum import of about 16 GW. The state-wise breakup of installed capacity and peak demand is summarised at **Table 6-1** below.

Table 6-1: Installed Capacity and Peak Demand of SR as on Feb'23

(All Fig in GW)

State	Generation							Grand Total	Peak Demand
	Fossil			Non Fossil					
	Thermal	Gas	Total	Nuclear	Hydro	RES	Total		
Andhra Pradesh	10.6	4.1	14.7	0.1	1.7	9.4	11.2	25.9	13.2
Telangana	9.5	0.8	10.3	0.1	2.5	5.1	7.7	18.1	14.8
Karnataka	10.4	0.0	10.4	0.7	3.6	16.6	20.9	31.3	15.5
Kerala	2.5	0.5	3.1	0.4	1.9	1.1	3.3	6.3	4.7
Tamil Nadu	14.9	1.0	15.9	1.4	2.2	17.7	21.4	37.3	17.3
Puducherry	0.2	0.0	0.2	0.0	0.0	0.0	0.0	0.2	0.5
NLC and Lakshadweep	0.3	0.0	0.3	0.1	0.0	0.0	0.1	0.4	0.0
Central unallocated	1.8	0.0	1.8	0.5	0.0	0.0	0.5	2.3	0.0
SR	50.3	6.5	56.8	3.3	11.8	49.9	65.0	121.8	61.1

Source: CEA monthly report

From above, it can be concluded that share of non-fossil fuel based generation capacity in total present installed capacity (IC) of 121.8 GW is 65 GW i. e 53% of total IC. This share would further increase in envisaged scenario of 2027-28 timeframe.

6.2 Envisaged Power Supply Scenario by 2027-28

As per the 20th EPS, Southern Region demand for 2027-28 timeframe is expected to increase to about 86.0 GW. As per the inputs received from various stakeholders, total installed capacity of Southern Region for 2027-28 is expected to be about 221 GW. The state wise bifurcation of installed capacity and peak demand is summarized below at **Table 6-2**

Table 6-2: Southern Region Installed Capacity and peak demand (2027-28)

(All Fig in GW)

State	Generation								ES S	Grand Total	Peak Demand
	Fossil			Non Fossil							
	Thermal	Gas	Total	Nuclear	Hydro	RES	Total				
Andhra Pradesh	6.4	0.5	6.9	0.0	3.2	7.7	10.9	1.4	19.1	19.1	
Telangana	10.8	0.0	10.8	0.0	0.9	2.7	3.6	1.6	16.0	21.0	
Karnataka	7.7	0.4	8.1	0.0	4.9	12.6	17.5	0.0	25.5	18.6	
Kerala	0.0	0.4	0.4	0.0	2.4	0.2	2.5	0.0	2.9	5.8	
Tamil Nadu	12.1	0.6	12.6	0.0	1.9	16.3	18.2	0.9	31.7	23.0	
Pudducherry	0.0	0.0	0.0	0.0	0.0	0.0	0.0	0.0	0.0	0.6	
Central	12.9	0.0	12.9	7.8	0.0	0.0	7.8	0.0	20.7	-	
IPP	4.6	0.0	4.6	0.0	0.0	87.5	87.5	13.0	105.1	-	
SR	54.5	1.8	56.3	7.8	13.2	133.9	154.9	16.8	221.	86.0	

From above, it is observed that growth in installed capacity of Southern Region is majorly from non-fossil fuel based generation resources. Share of non-fossil fuel based generation capacity in total present installed capacity (IC) has increased from 53% to 70%.

Compound annual growth rate in peak demand of Southern Region from present time-frame to 2027-28 is around 7 %. The state wise peak demand growth is given at **Table 6-3**:

Table 6-3: Increase in Peak Demand of Various States of SR

(All Fig in MW)

Peak Demand (MW)				
State	2022-23	2027-28	Difference	% CAGR
Andhra Pradesh	13167	19076	5909	7.7
Telangana	14794	20968	6174	7.2
Karnataka	15543	18578	3035	3.6
Kerala	4699	5818	1119	4.4
Tamil Nadu	17306	22976	5670	5.8
Puducherry	501	584	83	3.1
SR	61114	85953	24839	7.1

Therefore, annual growth rate in peak demand is maximum for Andhra Pradesh (7.7%) and minimum for Puducherry (3.1%).

6.3 Load Generation Balance for 2027-28 Timeframe

In chapter-1, all India Load Generation Balance (LGB) for identified nine scenarios was prepared as per the methodology finalized in consultation with CTU, CEA and Grid-India (Erstwhile GRID INDIA). This section elaborates the Southern Region Load Generation Balance (LGB) for 2027-28 time-frame. For Southern Region also, three points on the daily load curve i.e. Solar max (afternoon), Peak load (evening) and Off-peak load (night) for three seasons viz. Monsoon (August), Summer (June) and Winter (February) have been considered.

Load generation balance has been prepared considering the generation despatch factors as mentioned at **Table 6-4** for the 9 scenarios. Further, thermal generators have been despatched as per the merit order.

Table 6-4: Southern Region Generation Dispatch and Demand Factors

Scenario No & Name	Generation Dispatch Factors						Demand Factors
	Hydro	Nuclear	Solar	Wind	ESS	Gas	
1-Aug Solar Max	40%	80%	80%	55%	-100%	0%	83%
2-Aug Peak Load	70%	80%	0%	75%	60%	50%	70%
3-Aug Night Off Peak	40%	80%	0%	65%	40%	50%	58%
4-Jun Solar Max	40%	80%	85%	55%	-100%	0%	84%
5-Jun Peak Load	70%	80%	0%	75%	50%	50%	73%
6-Jun Night Off Peak	40%	80%	0%	65%	1%	50%	58%
7-Feb Solar Max	20%	80%	90%	0%	-100%	0%	85%
8-Feb Peak Load	40%	80%	0%	20%	60%	50%	74%
9-Feb Night Off Peak	20%	80%	0%	0%	40%	30%	51%

Using the above dispatch and demand factors, PSSE base case files for nine scenarios have been prepared. The despatch from thermal generations have been considered based on merit order. Based on the LGB, import / export of SR and the inter regional flows through various corridors are summarised in **Table 6-5**. Further, maximum and minimum is also highlighted in table below.

Table 6-5: Surplus/Deficit of Southern Region

All Fig in (MW)

State / UTs	Import / Export of Southern Region								
Scenario No Corridors	Aug'27 Time Frame			Jun'27 Time Frame			Feb'28 Time Frame		
	1 (Solar Max)	2 (Peak Load)	3 (Off Peak)	4 (Solar Max)	5 (Peak Load)	6 (Off Peak)	7 (Solar Max)	8 (Peak Load)	9 (Off Peak)
SR-ER	-1233	-139	93	692	-552	-837	-1247	-1794	-2469
SR-WR	13572	15937	11765	13191	16610	10287	6837	27	-4854
Southern Region	12339	15798	11858	13883	16058	9450	5590	-1767	-7323

Out of these nine scenarios, Scenario-5 and Scenario-9 corresponds to two extreme cases with respect to export/import i.e. highest export (16 GW) and highest import (7.3 GW) scenarios

respectively. In all other scenarios, import /export from Southern Region to other regions is varying between these two extremes.

Detailed system studies have been carried out on the finalized load flow cases. The study results are discussed in subsequent chapters.

Note : It is to mention that the above Load Generation Balance (LGB) has been worked on All India basis with various assumptions including the majority RE generation on potential basis, BESS and various despatch factors. This is leading Southern Region towards maximum surplus in power to the extent of 16 GW and deficit to the extent of about 7 GW only. However, the situation of surplus/deficit may significantly differ from the above scenarios, in case of deferment in materialisation of RE generations in SR grid. Under such scenarios, SR grid is expected to continue to be in deficit situations during peak load conditions (Feb-Apr/May of a Year) and import requirements from NEW grid are expected to further increase from the present level of 16 GW.

6.4 ISTS Network Expansion Schemes Evolved from Mar'22 to Feb'23

Various transmission schemes have been discussed/finalized in the Consultative Meeting for Evolution of Transmission System of Southern Region (CMETS-SR) from March 2022 to January 2023. Brief of all such deliberated transmission schemes are tabulated below at **Table 6-6:**

Table 6-6: Details of the schemes evolved in SR

Sl. No.	Name of the Transmission Scheme	Expected Timeframe	Tentative Cost (in Cr.)
Karnataka			
1.	Proposal for Augmentation of 1x500 MVA, 400/220kV ICT (6 th) and common facility works at Pavagada (Tumkur) PS	Dec'23	73.65
2.	Transmission Scheme for integration of Renewable Energy Zone (Phase-II) in Koppal-II (Phase-A) and Gadag-II (Phase- A)	2025-26	2564
3.	Transmission Scheme for integration of Renewable Energy Zone (Phase-II) in Koppal-II (Phase-B)	2025-26	1881
4.	Augmentation of transformation capacity by 1x500 MVA (4 th), 400/220kV ICT at Mysore substation in Karnataka	Apr'24	52.51
5.	Implementation of 2 nos. of 220kV line bays at Tumkur(Pavagada) 400/220kV PS for termination of Tumkur(Pavagada) – Pavagada(KPTCL) 220kV D/c line	2024-25	10
6.	Dynamic reactive compensation to mitigate voltage fluctuations around Bangalore area	Further deliberations required for finalization of the scheme	
7.	Transmission Scheme for integration of Devangere/Chitradurga REZ in Karnataka	2025-26	755
8.	Transmission Scheme for integration of Tumkur-II REZ in Karnataka	2025-26	798
9.	Transmission Scheme for integration of Bijapur REZ (Phase-I) in Karnataka	2025-26	579.57

Sl. No.	Name of the Transmission Scheme	Expected Timeframe	Tentative Cost (in Cr.)
Tamil Nadu			
4.	Augmentation of Transformation Capacity at Arasur	Feb'24	61
5.	Augmentation of Transformation Capacity at Hosur	Nov'23	46
Telangana			
2.	Augmentation of transformation capacity by 1x1500 MVA (3 rd), 765/400kV ICT at Maheshwaram (PG) substation in Telangana	2025-26	123.12
3.	Reconductoring of Raichur – Velloor (Mahabubnagar) 400 kV S/c line with HTLS conductor	2025-26	90
4.	Transmission Scheme for integration of Renewable Energy Zone in Nizamabad-II (1 GW Wind, 1 GW Solar), Medak (1.5 GW) and Rangareddy (1.5 MW) in Telangana	2025-26	4036.62

Details of the schemes are reproduced below state-wise:

6.4.1 Karnataka

a) Proposal for Augmentation of 1x500 MVA, 400/220kV ICT (6th) and common facility works at Pavagada (Tumkur) PS

Pavagada (Tumkur) PS was established with 5x500MVA, 400/220 KV ICTs as part of transmission scheme for Pavagada Ultra Mega Solar power park (2000 MW) in Tumkur, Karnataka. Presently, Connectivity / LTA of 2050 MW is under operation for Solar Power Park. Further additional Stage-II Connectivity for 1000 MW has been granted at Pavagada PS.

As per prevailing CEA's Manual on Transmission Planning Criteria, N-1 Contingency Criteria is not applicable for immediate connectivity of RE at ISTS/ Intra-STS grid i.e. dedicated line and immediate ICTs at grid station. To facilitate the integration of proposed RE projects at Pavagada PS, implementation of 220kV bus sectionalizer along with bus coupler & transfer bus coupler are required in line with CEA Transmission Planning Criteria and Technical Standards for Construction. Further, for evacuation of additional power from proposed RE based generation project, augmentation of transformation capacity by 1x500 MVA, 400/220 kV ICT (6th) is required.

Accordingly, proposal of augmentation of 1X500 MVA, 400/220kV ICT (6th) and common facility works at Pavagada (Tumkur) PS was discussed and agreed for implementation in the 5th Consultative Meeting for Evolution of Transmission System of Southern Region (CMETS-SR) held on 25.03.2022. Detailed scope of the scheme is as mentioned below:

Sl. No	Scope of the Transmission Scheme	Capacity	Implementation Timeframe
1.	Augmentation of transformation capacity by 1X500 MVA, 400/220kV ICT (6 th) at Pavagada	a) 1x500 MVA, 400/220 kV ICT b) 400kV ICT bay – 1 no c) 220kV ICT bay – 1 no	Dec'23

SI. No	Scope of the Transmission Scheme	Capacity	Implementation Timeframe
2.	Implementation of 220kV bus sectionalizer along with bus coupler & transfer bus coupler at Pavagada PS	a) 220kV Bus Sectionalizer Bay – 1 Set b) 220kV Bus Coupler Bay – 1 no c) 220kV TBC bay – 1 no	Dec'23
Total Estimated Cost			62.52 Crore

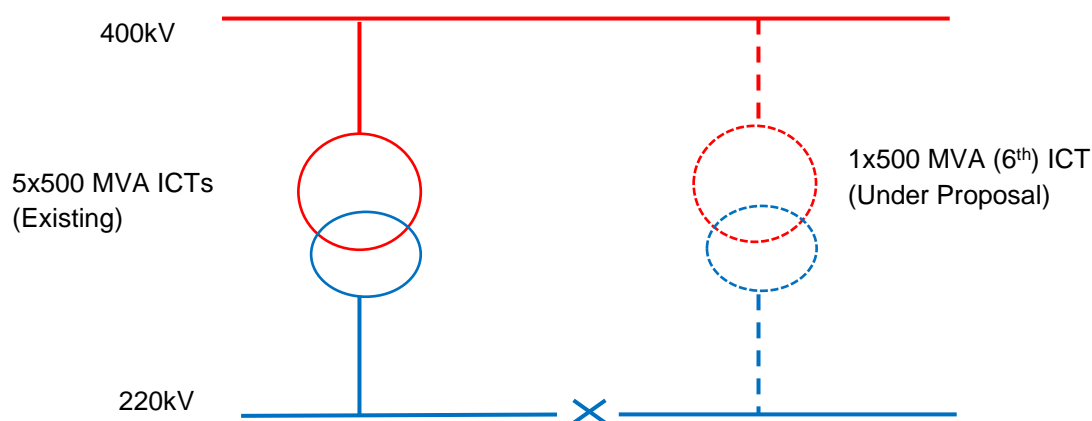

Figure 6-1: Augmentation of 1x500 MVA, 400/220kV ICT (6th) at Pavagada (Tumkur) PS

b) Transmission Scheme for integration of additional RE potential in Gadag, Koppal, Davangere, Bijapur and Bellary Area of Karnataka

As part of transmission system planning for 18.5 GW in Southern Region, CTU has planned the Koppal PS and Gadag PS in the state of Karnataka with 5x500 MVA, 400/220 kV ICTs. The Transmission System associated with Koppal PS and Gadag PS are under advance stage of implementation. Accordingly, Koppal PS and Gadag PS have been closed for further grant of Connectivity through allocation of new bay(s). However, margins available in the allocated bay(s) shall be utilized for Connectivity through enhancement in Connectivity quantum or sharing of dedicated transmission line.

Further, Govt. of India has set a target of 500 GW non-fossil fuel based generation capacity by 2030. In this direction, MNRE has identified the 181.5 GW of RE Potential in the states of Andhra Pradesh, Telangana, Karnataka, Rajasthan, Madhya Pradesh and Tamil Nadu (Offshore). Out of the identified 181.5 GW Potential, 86 GW RE Potential is identified in the State of Andhra Pradesh, Telangana Karnataka and Tamil Nadu (Offshore) in Southern Region. The transmission system for integration of the RE Potential is under advanced stage of identification.

Out of this 86 GW RE Potential in Southern Region, 17 GW has been identified in the State of Karnataka. MNRE have indicated that out of the 17 GW REZ potential in Karnataka, transmission system for evacuation capacity of 10.5 GW may be identified considering the Energy Storage System. The details of district wise RE potential and evacuation capacity to be planned considering Wind & Solar dispatch are given below:

District	Potential (GW)		Total (GW)	Dispatch (90% S+55% W)	BESS	Evacuation capacity to be planned (GW)
	Wind	Solar				
Koppal	2	2	4	2.9	1	2
Gadag	2	2	4	2.9	1	2
Davangere / Chitradurga	2	2	4	2.9	1	2
Bijapur	2		2	1.1		2
Bellary		1.5	1.5	1.35		1.5
Tumkur		1.5	1.5	1.35		1.5
Total	8	9	17	12.5	3	11

Further, it was informed that SECI vide its email dated 08.05.2022 has informed that they have floated tenders for selection of RE developer and it is likely that developer would opt for setting up of these RE projects in Koppal and Gadag area of Karnataka. Accordingly, SECI has requested to prioritize the development of associated transmission system for integration of additional potential at Koppal and Gadag.

Also, CTU is continuously receiving Connectivity applications and representations from RE developers for further augmentation of capacity at under implementation Koppal PS and Gadag PS so that they may further integrate the proposed RE generation projects in the area. CTU is already in receipt of Stage-II Connectivity applications of about 900 MW at Koppal-II / Gadag-II area (Koppal-II – 400 MW & Gadag-II – 500 MW).

The 765/400/220kV Koppal-II PS is being envisaged for final capacity of about 9 GW considering the integration of above pooling stations. Accordingly, CTU has carried out detailed system studies for the 2025-2026 timeframe and identified the additional transmission system as advanced action for integration and immediate evacuation of additional RE potential of 2 GW at Koppal and Gadag each as well as integration of RE potential at Gadag, Davangere, Bijapur and Bellary through 400kV transmission lines with Koppal-II PS 765/400/220kV.

The scheme was discussed and agreed in the Joint Study meeting of Southern Region Constituents held on 30th June – 2nd July, 2022 at SRPC, Bengaluru. The scheme was also agreed in the 9th CMETS(SR) held on 29.07.2022. The details of envisaged transmission system for integration and evacuation of RE potential from Koppal-II and Gadag-II and Common Transmission Scheme for integration of additional RE potential in Gadag, Davangere, Bijapur and Bellary are as given below:

District	Potential (GW)		Total (GW)	Dispatch (90% S+55% W)	BESS	Evacuation capacity to be planned (GW)
	Wind	Solar				
Koppal	2	2	4	2.9	1	2
Gadag	2	2	4	2.9	1	2
Total	4	4	8	5.8	2	4

- (i) **Transmission Scheme for Renewable Energy Zone (Phase-II) in Koppal-II in Karnataka and Common Transmission Scheme for integration of additional RE potential in Gadag, Davangere, Bijapur and Bellary.**

a. Phase-A

- Establishment of 765/400kV 2x1500 MVA, 400/200kV 2x500 MVA Koppal-II Pooling Station with provision of two (2) sections of 4500 MVA each at 765/400kV level and provision of four (4) sections of 2500 MVA each at 400/220kV level
- Koppal-II PS – Narendra New 765kV D/c line with 240 MVAr SLR at Koppal-II PS end (~150 km)
- 2x330 MVAr (765kV) & 2x125MVAr (400kV) bus reactors at Koppal-II PS
- Provision for 25 acres of land for establishment of BESS at Koppal-II PS

b. Phase-B

- Koppal-II PS – Raichur 765kV D/c line with 330 MVAr SLR at Koppal-II PS end (~190 km)
- Augmentation of 2x1500, 765/400kV, ICTs at Koppal-II PS.
- Augmentation of 2x500, 400/220kV, ICTs at Koppal-II PS.

Future Provisions

- Space provision for 8 nos. of 400/220kV, 500 MVA ICTs at Koppal-II PS
- Space for 4 nos. of 765/400kV, 1500 MVA ICTs at Koppal-II PS

(ii) Transmission Scheme for Renewable Energy Zone (Phase-II) in Gadag-II Phase A in Karnataka

- Establishment of 400/220kV, 2x500 MVA Gadag-II Pooling Station
- Gadag-II PS – Koppal-II PS 400kV (Quad Moose) D/c line (~100 km)
- 2x125MVAr 420kV bus reactors at Gadag-II PS
- Provision for 25 acres of land for establishment of BESS at Gadag-II PS

Future Provisions

- Space provision for 10 nos. of 400/220kV, 500 MVA ICTs at Gadag-II PS

The Gadag-II REZ is being integrated with Koppal-II PS through Gadag-II PS – Koppal-II PS 400kV (Quad Moose) D/c line and Gadag-II REZ evacuation and integration is dependent on Koppal-II PS. Accordingly, the scheme “Transmission Scheme for integration of Renewable Energy Zone (Phase-II) in Koppal-II (Phase-A)” and “Transmission Scheme for integration of Renewable Energy Zone (Phase-II) Gadag-II” are required to be implemented simultaneously as a single scheme.

Implementation of transmission system shall be taken up in phased manner subject to materialization of RE projects as decided in the joint study meeting of SR Constituents, CTU, CEA & GRID INDIA. Phase-B transmission system of Koppal-II shall be implemented after cumulative grant of Connectivity / LTA beyond 2500 MW at Koppal-II and Gadag-II REZs.

Further, the transmission scheme was discussed in the 43rd SRPC meeting held on 23.09.2022 and SRPC vide letter dated 04.10.2022 has forwarded the views of SRPC on the scheme. The transmission scheme had been agreed by GRID-India/SRLDC and SRPC Secretariat. Subsequently, the transmission scheme was discussed in the 10th NCT meeting held on

07.11.2022 wherein it was decided that Koppal Phase-A & Gadag Phase-A and Koppal Phase-B schemes would be clubbed together for bidding purpose through TBCB route with implementation timeframe of 24 months and 36 months respectively. Following scheme was finalized in the meeting:

Transmission Scheme for integration of Renewable Energy Zone (Phase-II) in Koppal-II (Phase-A) and Gadag-II (Phase- A) in Karnataka

Koppal-II (Phase-A)

- Establishment of 765/400kV 2x1500 MVA, 400/200kV 2x500 MVA Koppal-II Pooling Station with provision of two (2) sections of 4500 MVA each at 765/400kV level and provision of four (4) sections of 2500 MVA each at 400/220kV level
- Koppal-II PS – Narendra New 765kV D/c line with 240 MVAr SLR at Koppal-II PS end (~150 km)
- 2x330 MVAr (765kV) & 2x125MVAr (400kV) bus reactors at Koppal-II PS
- Provision for 25 acres of land for establishment of BESS at Koppal-II PS

Gadag-II (Phase-A)

- Establishment of 400/220kV, 2x500 MVA Gadag-II Pooling Station
- Gadag-II PS – Koppal-II PS 400kV (Quad Moose) D/c line (~100 km)
- 2x125MVAr 420kV bus reactors at Gadag-II PS
- Provision for 25 acres of land for establishment of BESS at Gadag-II PS

Transmission Scheme for integration of Renewable Energy Zone (Phase-II) in Koppal-II (Phase-B) in Karnataka

- Koppal-II PS – Raichur 765kV D/c line with 330 MVAr SLR at Koppal-II PS end (~190 km)
- Augmentation of 2x1500, 765/400kV, ICTs at Koppal-II PS.
- Augmentation of 2x500, 400/220kV, ICTs at Koppal-II PS.

c) Augmentation of transformation capacity by 1x500 MVA (4th), 400/220kV ICT at Mysore substation in Karnataka

Mysore substation was established with 2x315MVA, 400/220 KV ICTs as part of regional system strengthening scheme in Karnataka. Subsequently, the substation was augmented with 1X500 MVA ICT and presently Mysore substation is having 1130 MVA (2x315 + 1x500 MVA) transformation capacity.

Under peak load scenario of Southern Region, ICTs at Mysore substation are highly overloaded and therefore augmentation of 1x500 MVA (4th), 400/220kV transformation capacity at Mysore substation in Karnataka was deliberated in various meetings. ICT constraints at Mysore were also continuously highlighted by GRID INDIA in its quarterly operational feedback. Further, POWERGRID in the 195th OCC meeting held on 11.10.2022 submitted that the existing ICTs (2x315 + 1x500 MVA) at Mysore are continuously over loaded and N-1 contingency is not being fulfilled. Accordingly, they requested for augmentation of ICT at

Mysore. The OCC forum recommended the proposal of 4th ICT at Mysore and the proposal for augmentation of transformation capacity by 1x500 MVA (4th), 400/220kV ICT at Mysore substation was discussed in the 42nd TCC meeting held on 21.10.2022 wherein KPTCL gave concurrence for 4th ICT at Mysore.

Accordingly, proposal for implementation of 1x500 MVA (4th), 400/220kV ICT at Mysore for improving the reliability and meeting the contingency during peak demand was agreed in the 13th CMETS-SR held on 30.11.2022 for implementation with schedule of 15 months (Best efforts – 12 months) so that ICT may be available before the peak demand season of 2024.

Sl. No	Scope of the Transmission Scheme	Capacity	Implementation Timeframe
1.	Augmentation of transformation capacity by 1X500 MVA, 400/220kV ICT (4 th) at Mysore substation in Karnataka	d) 1x500 MVA, 400/220 kV ICT e) 400kV ICT bay – 1 no f) 220kV ICT bay – 1 no g) 220kV GIS duct – 540m	Apr'24
Total Estimated Cost			52.51 Crore

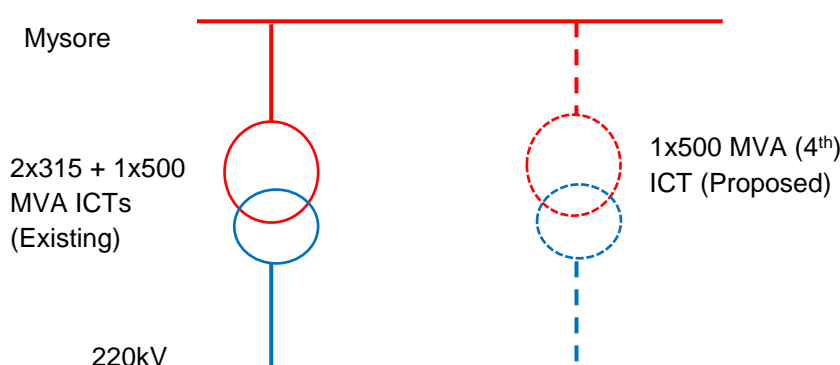

Figure 6-2: Augmentation of 1X500 MVA, 400/220kV ICT (4th) ICT at Mysore S/s

d) Implementation of 2 nos. of 220kV line bays at Tumkur(Pavagada) 400/220kV PS for termination of Tumkur(Pavagada) – Pavagada(KPTCL) 220kV D/c line

Pavagada(KPTCL) 220kV substation is radially fed from Madhugiri and does not have alternate source of supply. Therefore, additional connectivity from Tumkur(Pavagada) has been planned for reliability and implementation of Tumkur(Pavagada) PS – Pavagada(KPTCL) 220 kV D/c line along with allocation of space for 2 nos. of 220 kV line bays at Tumkur (Pavagada) PS to KPTCL (under the scope of KPTCL) were agreed as 2nd source of power supply to Pavagada(KPTCL) 220kV substation in the 1st SRPC(TP) meeting held on 16.12.2019. However, KPTCL shall ensure that no power shall be injected into the Pavagada PS (POWERGRID) Subsequently, KPTCL vide letter dated 15.07.2022 requested that implementation of 2 nos. of 220kV line bays at Tumkur(Pavagada) 400/220kV PS for termination of Tumkur(Pavagada) – Pavagada(KPTCL) 220kV D/c line may be exempted from the scope of KPTCL and may be implemented under ISTS as part of system improvement

work. Accordingly, the matter regarding implementation of 220kV line bays under ISTS was taken up for deliberation in the 10th CMETS-SR held on 26.08.2022. In the meeting, SRLDC highlighted that with the proposed Tumkur(Pavagada) – Pavagada(KPTCL) 220kV D/c line, heavy power flows towards 220kV system of Karnataka is observed. Accordingly, it was decided that Tumkur(Pavagada) – Pavagada(KPTCL) 220kV D/c line may be implemented with high capacity conductor line along with strengthening of the downstream network and implementation of 2 nos. of 220kV line bays at Tumkur(Pavagada) 400/220kV PS shall be under ISTS.

e) Dynamic reactive compensation to mitigate voltage fluctuations around Bangalore area

Large voltage fluctuations around Bangalore area has been highlighted by GRID INDIA at different forums. During off peak demand period, voltage of buses around Bangalore area remain high for considerable period whereas voltage dips during peak demand time. The issue has also been highlighted in the quarterly operational feedback report of SRLDC. Voltage of Yelahanka, Bidadi, Nelamangla etc. remained high during off peak period for last one year. Therefore, SRLDC has emphasized on the need of dynamic reactive power compensation around Bangalore area. Further, in the meeting held on 09.06.2022 under the chairmanship of Member (Power System), CEA, KPTCL informed that they are planning to dismantle unutilized 220 kV bays at Yelahanka S/s as full capacity of 2x500 MVA transformer may be utilized through 220 kV Yelahanka – DG Plant 2x2000 sq mm UG cable. In the meeting, CTU suggested that the space can be utilized for planning of ± 200 MVAR STATCOM to mitigate the voltage fluctuations around Bangalore area. Members agreed with CTU suggestion for planning STATCOM for controlling voltage fluctuations around Bangalore area.

In view of same, CTU has carried out preliminary study analysis in off-peak file of present time frame provided by SRLDC for working out the requirement of dynamic reactive power compensation. From the analysis, it emerged that considering ± 200 MVAR STATCOM with 1x125 MVAR MSC and 1x125 MVAR MSR, voltage around Bangalore area gets better and bidirectional reactive compensation (both reactive and capacitive) is achieved. Accordingly, proposal for implementation of STATCOM of ± 200 MVAR with 1x125 MVAR MSC and 1x125 MVAR MSR at Yelahanka substation utilizing the space of dismantled 4 nos. of 220 kV bays of KPTCL was deliberated with the constituents in the 14th CMET-SR held on 26.12.2022 to provide bidirectional reactive compensation (both reactive and capacitive). During the 14th CMET-SR, it was decided that proposal for Yelahanka STATCOM would be finalized in the joint study meeting scheduled in Feb'23. Accordingly, the proposal was deliberated and agreed in the joint study meeting held on 21st & 22nd Feb'23. The scheme shall be further deliberated in the 16th CMET-SR scheduled on 31st Mar'23.

f) Transmission Scheme for integration of Renewable Energy Zone in Devangere/Chitradurga (2 GW Wind, 2 GW Solar, 1 GW BESS), Tumkur-II (1.5 GW Solar) and Bijapur (1 GW Wind) in Karnataka

Govt. of India has set a target of 500 GW non-fossil fuel-based generation capacity by 2030. In this direction, MNRE has identified the 181.5 GW of RE Potential in the states of Andhra

Pradesh, Telangana, Karnataka, Rajasthan, Madhya Pradesh and Tamil Nadu (Offshore). Out of the identified 181.5 GW Potential, 86 GW RE Potential is identified in the State of Andhra Pradesh (51 GW), Telangana (13 GW), Karnataka (17 GW) and Tamil Nadu (5 GW Offshore) in Southern Region. Details of the potential identified in the state of Karnataka is given below:

State/District	Pooling Station	Identified Potential (GW)		Maximum Dispatch (GW)	BESS (GW)	Evacuation System (GW)
		Wind	Solar			
Karnataka (17 GW)						
Koppal	Koppal-II	2	2	3	1	2
Gadag	Gadag-II	2	2	3	1	2
Devanagere/Chitradurga	Devanagere/Chitradurga	2	2	3	1	2
Bijapur	Bijapur	2	0	2		2
Bellary	Bellary	0	1.5	1.5		1.5
Tumkur	Tumkur-II	0	1.5	1.5		1.5
Sub Total (Karnataka)		8	9	14	3	11

The transmission system for integration of 181.5 GW RE Potential has been identified by CEA and a report on Transmission System for Integration of over 500 GW RE Capacity has been published by CEA on 07.12.2022. Out of the 17 GW RE Potential identified in the State of Karnataka, transmission system for evacuation capacity of about 11 GW has been identified considering the Solar-Wind dispatch factors and Energy Storage System.

The transmission system for integration of additional RE potential in Koppal-II and Gadag-II area of Karnataka was already agreed and the same was also included in the interim report of Rolling Plan for 2027-28 timeframe. Based on the communication from SECI, a meeting was held under the chairmanship of Chairperson, CEA on 03.11.2022 to discuss the implementation of Transmission system for RE Zones at Ananthapuram, Kurnool, Bidar and some other RE Potential zones. During the meeting, it was decided that transmission system for evacuation of power from other RE Zones suggested by SECI viz. Devangere/Chitradurga & Tumkur-II in Karnataka would be put up to NCT after deliberations in CMETS and SRPC forum. Based on the request of SECI and decision in the Chairperson, CEA meeting, transmission system for integration of Devangere/Chitradurga REZ (2 GW Wind, 2 GW Solar, 1 GW BESS) and transmission system for integration of Tumkur REZ (1.5 GW Solar) as identified in the CEA report was deliberated with the SR Constituents in the 14th CMETS-SR held on 26.12.2022.

Further, a meeting was held on 11.01.2023 under the chairmanship of Secretary (Power) to review the progress of under construction/under bidding/planned transmission projects for evacuation of renewable energy projects and constraints, if any, in evacuating RE energy. During the meeting, it was decided that in order to reduce time taken for implementation of ISTS required for RE evacuation, approval of NCT/MoP could be taken in advance and bidding could be started based on ground situation of visibility of RE generations. Accordingly, CTUIL was requested to expedite the same.

Accordingly, approval process of transmission system for potential locations identified under phase-I of the CEA report has been initiated and transmission system for integration of Bijapur

(1 GW Wind) was deliberated with the SR Constituents in the 15th CMETS-SR held on 30.01.2023.

Details of the transmission schemes are given:

(i) Transmission System for integration of Devanagere/Chitradurga REZ (2 GW Wind, 2 GW Solar, 1 GW BESS)

- Establishment of 400/220kV 3x500 MVA Pooling Station near Devanagere/ Chitradurga, Karnataka (1 GW injection at 220 kV level and 1 GW injection at 400 kV level)
- Devanagere / Chitradurga PS – Koppal-II PS 400kV (Quad ACSR Moose) D/c line (~100 km)
- 2x125MVAr 420 kV bus reactors at Devanagere / Chitradurga PS

(ii) Transmission System for integration of Tumkur REZ (1.5 GW Solar)

- Establishment of 4x500 MVA, 400/220 kV Pooling Station near Tumkur, Karnataka
- Tumkur-II PS – Tumkur(Pavagada) 400kV (Quad ACSR Moose) D/c line (~100 km)
- 2x125MVAr 420kV bus reactors at Tumkur-II PS

(iii) Transmission System for integration of Bijapur REZ (1 GW Wind)

- Establishment of 400/220kV 2x500 MVA Pooling Station near Bijapur (Vijayapura), Karnataka
- Bijapur PS – Koppal-II PS 400kV (Quad ACSR Moose) D/c line (~100 km)
- 2x125MVAr 420 kV bus reactors at Bijapur PS

For optimal utilization of transmission system, power from other RE Zones in Karnataka viz. Gadag-II, Davangere, Bijapur and Bellary area would be pooled at Koppal-II PS through 400 kV lines for further transfer of power. Accordingly, Davangere REZ is being integrated with Koppal-II PS through Davangere / Chitradurga PS – Koppal-II PS 400kV (Quad ACSR Moose) D/c line. Further, Tumkur REZ is being integrated with existing Tumkur (Pavagada) PS through Tumkur-II PS – Tumkur (Pavagada) 400kV (Quad ACSR Moose) D/c line.

The transmission schemes for Davangere/Chitradurga and Tumkur REZs has been sent to SRPC for their views. Thereafter, approval of NCT would be taken. The transmission scheme for Bijapur REZ shall be sent to SRPC for their views shortly

6.4.2 Tamil Nadu

a) Augmentation of Transformation Capacity at Arasur S/s and Hosur S/s:

SRLDC vide letter dated 05.05.2022 has communicated that Southern Region has met a record maximum demand of 60,876 MW on 1st April, 2022 during this peak demand season. Similarly, Tamil Nadu has met an all-time maximum demand of 17,196 MW on 29th March, 2022. It was also informed that the transmission system in Tamil Nadu experiences severe loading on 400/230kV ICTs and intra-state transmission lines every year during the peak demand season. Further, Tamil Nadu may experience a peak demand of about 27000 MW in 2026-27 as per the 19th EPS and may have an import requirement of approx. 18000 MW. With future LTA/MTOA being contracted to Tamil Nadu the violation in ATC would increase, therefore augmentation of ICTs & Intra-State Transmission System is required on urgent basis.

The 400/230kV ICTs at most of the stations are operated without meeting N-1 contingency criteria and tripping of one these ICTs during such high loading may leads to cascade tripping and may result in loss of large quantum of load / generations. Further, the augmentation of transformation capacity at Hosur with 1x500 MVA was deliberated in the 3rd SRPC(TP) meeting held on 24.08.2021. The transmission constraints in Tamil Nadu were also discussed in the special meeting of SRPC held on 17.05.2022. During the meeting, it was decided that suitable ICT augmentations at specified locations may be taken up by TANTRANSOCO and CTU. Accordingly, augmentation of 1x500 MVA, 400/230kV transformation capacity each at Arasur and Hosur substations for improving the reliability and meeting the contingency criteria in meeting the peak demand of Tamil Nadu was discussed and agreed in the 7th CMETS(SR) & 8th CMETS(SR) held on 31.05.2022 & 28.06.2022 respectively. Detailed scope of the scheme is as mentioned below:

SI. No.	Scope of the Transmission Scheme	Capacity/km	Total Estimated Cost	Implementation timeframe
1.	Augmentation of 1x500 MVA, 400/230kV transformation capacity at Arasur S/s	<ul style="list-style-type: none"> • 1x500 MVA, 400/230 kV ICT • 400kV ICT bay – 1 No. • 230kV ICT bay – 1 No. (For ICT interconnection to 230kV Switchyard, 245kV Cable / GIB shall be required)	61 Crore	18 months from date of CTU OM
2.	Augmentation of 1x500 MVA, 400/230kV transformation capacity at Hosur S/s	<ul style="list-style-type: none"> • 1x500 MVA, 400/230 kV ICT • 400kV ICT bay – 1 No. • 230kV ICT bay – 1 No. 	46 Crore	15 months from date of CTU OM

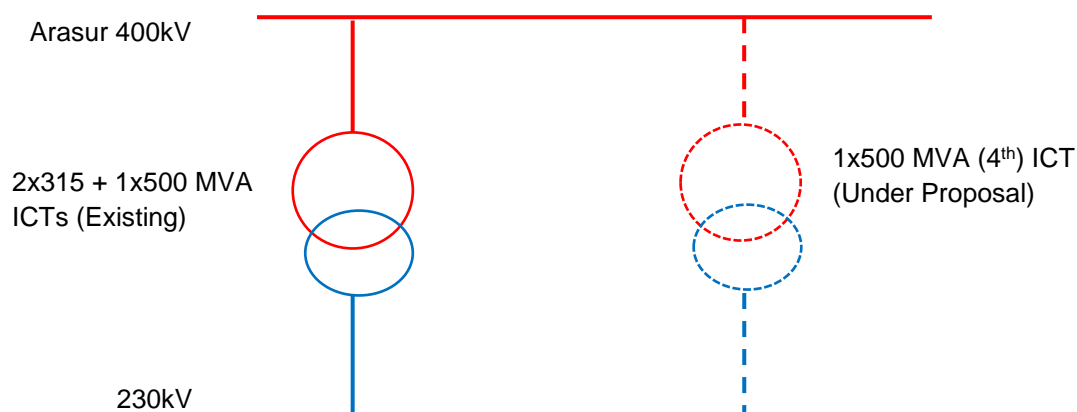

Figure 6-3: Augmentation of 1x500 MVA, 400/230kV ICT at Arasur S/s

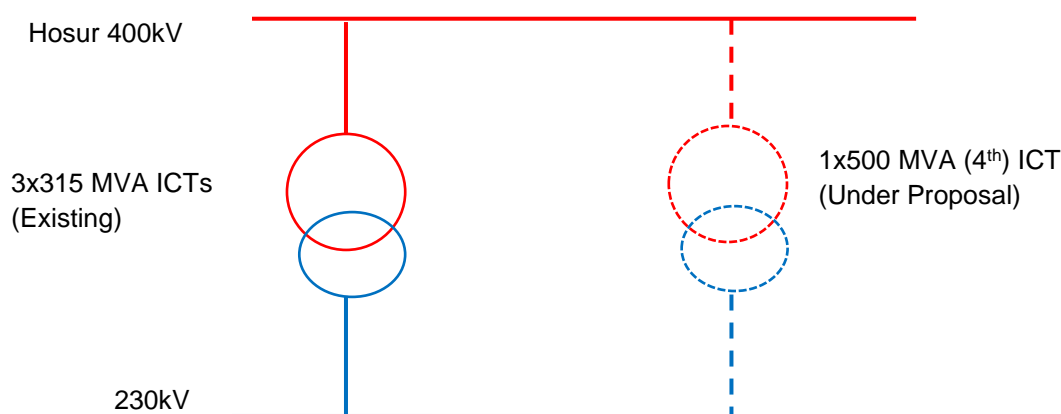

Figure 6-4: Augmentation of 1x500 MVA, 400/230kV ICT at Hosur S/s

6.4.3 Telangana

a) Augmentation of transformation capacity by 1x1500 MVA (3rd), 765/400kV ICT at Maheshwaram (PG) substation in Telangana

765/400kV Maheshwaram (PG) GIS is existing ISTS substation of POWERGRID with 2x1500MVA transformation capacity. In the meeting held on 19.09.22 on intra-state proposals of APTRANSCO and TSTRANSCO wherein bus splitting scheme to reduce the high short circuit levels at 400kV Maheshwaram (TS) bus & Mamidipally was agreed, overloading of existing ICTs (2x1500 MVA) at Maheshwaram (GIS) was highlighted and it was also observed that N-1 contingency criterion is not getting satisfied for the 765/400kV ICTs. As per the studies carried out as part of Rolling Plan exercise, under N-1 contingency of one ICT, loading on the other is around 114% of rating and therefore augmentation of 1x1500 MVA 765/400kV ICT (3rd) at Maheshwaram is required. SRLDC also highlighted overloading of Maheshwaram ICTs in their quarterly operational feedback report and requested for augmentation of transformation capacity at Maheshwaram by 1x1500 MVA, 765/400kV ICT.

Accordingly, proposal for augmentation of 1x1500 MVA (3rd) transformation capacity at Maheshwaram (PG) GIS for improving the reliability and meeting the contingency criteria was agreed for implementation in the 14th CMETS-SR held on 26.12.2022 with implementation schedule of 21 months.

SI. No	Scope of the Transmission Scheme	Capacity	Total Estimated Cost	Implementation Timeframe
1.	Augmentation of 1x1500 MVA, 765/400kV transformation capacity at Maheshwaram(PG) S/s	a) 1x1500 MVA, 765/400 kV ICT b) 765kV ICT bay – 1 No. c) 400kV ICT bay – 1 No.	123.12 Cr	21 months from the date of issue of OM by CTUIL

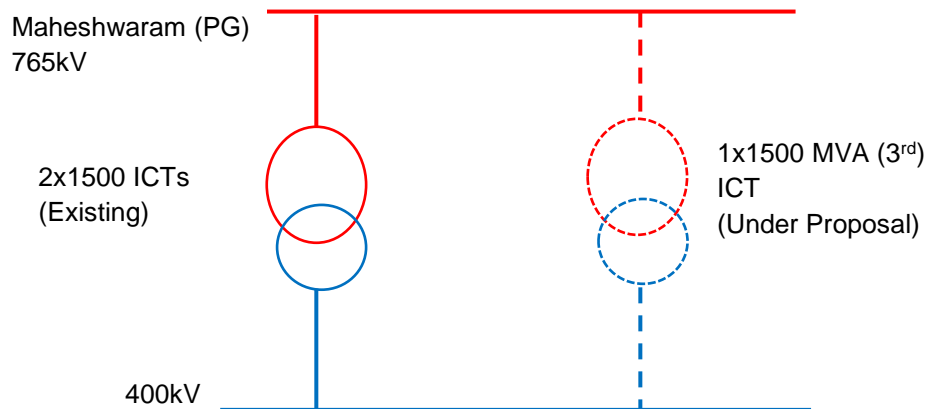

Figure 6-5: Augmentation of 1x1500 MVA, 765/400kV /ICT at Maheshwaram(PG)

b) Reconductoring of Raichur – Veltloor (Mahabubnagar) 400 kV S/c line with HTLS conductor

Raichur – Veltloor (Mahabubnagar) 400 kV S/c line is an ISTS line owned by POWERGRID designed at 45-75 deg. During Peak wind season in Southern Region, loading on the Raichur – Veltloor (Mahabubnagar) 400 kV S/c remains high for substantial amount of time. SRLDC informed that line flow is as high as 700 MW during peak wind scenario. Further, in the interim report for the ISTS Rolling Plan 2027-28 published by CTU on 30.09.2022, loading on Raichur – Veltloor(Mahabubnagar) 400kV S/c line is crossing its thermal rating (850 MVA) under N-1 contingency. TSTRANSCO informed that on account of high loading on the Raichur – Veltloor (Mahabubnagar) 400 kV S/c line, TTC of Telangana is restricted and suitable augmentation may be explored. Subsequently, POWERGRID had confirmed the possibility of reconductoring of Raichur – Veltloor (Mahabubnagar) 400 kV S/c line with HTLS conductor.

Considering the above, proposal of reconductoring of the Raichur – Veltloor (Mahabubnagar) 400 kV S/c line with HTLS conductor was deliberated and agreed in the 15th CMETS-SR held on 31.01.2023.

c) Transmission Scheme for integration of Renewable Energy Zone in Nizamabad-II (1 GW Wind, 1 GW Solar), Medak (1.5 GW) and Rangareddy (1.5 MW) in Telangana

Govt. of India has set a target of 500 GW non-fossil fuel based generation capacity by 2030. In this direction, MNRE has identified the 181.5 GW of RE Potential in the states of Andhra Pradesh, Telangana, Karnataka, Rajasthan, Madhya Pradesh and Tamil Nadu (Offshore). Out of the identified 181.5 GW Potential, 86 GW RE Potential is identified in the State of Andhra Pradesh (51 GW), Telangana (13 GW), Karnataka (17 GW) and Tamil Nadu (5 GW Offshore) in Southern Region. Details of the potential identified in the state of Telangana is given below:

State/District	Pooling Station	Identified Potential (GW)		Maximum Dispatch (GW)	BESS (GW)	Evacuation System (GW)
		Wind	Solar			
Telangana (13 GW)						
Rangareddy	Rangareddy	1	2.5	3	1	2
Medak	Medak	1	2.5	3	1	2
Nizamabad	Nizamabad-II	1	2.5	3	1	2
Karimnagar	Karimnagar	0	2.5	2.5	0	2.5
Sub Total (Telangana)		3	10	11.5	3	8.5

The transmission system for integration of 181.5 GW RE Potential has been identified by CEA and a report on Transmission System for Integration of over 500 GW RE Capacity has been published by CEA on 07.12.2022. Out of the 13 GW RE Potential identified in the State of Telangana, transmission system for evacuation capacity of about 8.5 GW has been identified considering the Solar-Wind dispatch factors and Energy Storage System.

Based on the communication from SECI, a meeting was held under the chairmanship of Chairperson, CEA on 03.11.2022 to discuss the implementation of Transmission system for RE Zones at Ananthapuram, Kurnool, Bidar and some other RE Potential zones. During the meeting, it was decided that transmission system for evacuation of power from other RE Zones suggested by SECI viz. Nizamabad-II in Telangana would be put up to NCT after deliberations in CMETS and SRPC forum. Based on the request of SECI and decision in the Chairperson, CEA meeting, transmission system for integration of Nizamabad-II (2 GW Wind, 2.5 GW Solar, 1 GW BESS) as identified in the CEA report published on 07.12.2022 was deliberated with the SR Constituents in the 14th CMETS-SR held on 26.12.2022.

Further, a meeting was held on 11.01.2023 under the chairmanship of Secretary (Power) to review the progress of under construction/under bidding/planned transmission projects for evacuation of renewable energy projects and constraints, if any, in evacuating RE energy. During the meeting, it was decided that in order to reduce time taken for implementation of ISTS required for RE evacuation, approval of NCT/MoP could be taken in advance and bidding could be started based on ground situation of visibility of RE generations. Accordingly, CTUIL was requested to expedite the same.

Accordingly, approval process of transmission system for potential locations identified under phase-I has been initiated and transmission system for integration of Medak (1 GW Wind, 0.5 GW Solar) and Rangareddy (1 GW Wind, 0.5 GW Solar) as identified in the CEA report published on 07.12.2022 was deliberated with the SR Constituents in the 15th CMETS-SR held on 30.01.2023.

Details of the transmission schemes are given:

(i) Transmission System for integration of Nizamabad REZ (1 GW Wind, 2.5 GW Solar, 1 GW BESS)

- Establishment of 765/400/220kV 6x1500 MVA, 3x500 MVA Pooling Station near Nizamabad (Nizamabad-II) (1 GW injection at 220 kV level and 1 GW injection at 400 kV level)

- Augmentation by 1x1500 MVA, 765/400 kV ICT at Nizamabad (PG) S/s
- Nizamabad-II PS – Nizamabad (PG) 765kV 2x D/c line (~30 km)
- Nizamabad-II PS – Warangal (New) 765kV D/c line with 330 MVA SLR at Nizamabad-II PS (~180 km)
- 2x330 MVA (765kV) & 2x125MVA (400kV) bus reactors at Nizamabad-II PS

(ii) Transmission System for integration of Medak REZ (1 GW Wind, 0.5 GW Solar)

- Establishment of 400/220kV 2x500 MVA Pooling Station near Medak (Medak PS) (1 GW injection at 220 kV level and 1 GW injection at 400 kV level)
- Medak PS – Nizamabad-II 400kV (Quad ACSR Moose) D/c line (~60 km)
- 2x125MVA 420kV bus reactors at Medak PS

(iii) Transmission System for integration of Rangareddy REZ (1 GW Wind, 0.5 GW Solar)

- Establishment of 400/220kV 2x500 MVA Pooling Station near Rangareddy (Rangareddy PS) (1 GW injection at 220 kV level and 1 GW injection at 400 kV level)
- Rangareddy PS – Nizamabad-II 400kV (Quad ACSR Moose) D/c line with 80 MVA SLR at Rangareddy PS (~155 km)
- 2x125MVA 420kV bus reactors at Rangareddy PS

For optimal utilization of transmission system, power from other RE Zones in Telangana viz. Medak and Rangareddy area (part of 181.5 GW RE capacity addition by 2030) would be pooled at Nizamabad-II PS for further evacuation through 400 kV lines. Accordingly, Medak REZ is being integrated with Nizamabad-II PS through Medak PS – Nizamabad-II PS 400kV (Quad ACSR Moose) D/c line and Rangareddy PS – Nizamabad-II PS 400kV (Quad ACSR Moose) D/c line.

6.5 Measures Taken for Mitigation of Issues of Previous Rolling Plans

6.5.1 Measures for controlling overloading of Transmission lines

Following ISTS lines were observed to be loaded beyond 90% of thermal rating under N-1 contingency as per the analysis carried out in the ISTS Rolling Plan 2027-28 timeframe (Interim Report):

(All Fig in MVA)

Sl. No	Name of the Line	Contingency	Scenario No.	Owner	Base case Loading	Loading under N-1	Rating	% Loading
1	Pugalur New – Karur 400kV (Quad) D/c line	Pugalur New – Karur 400kV one ckt	2, 3, 5, 6	ISTS	1379	2369	2186 (Quad Moose)	108%
2	Raichur - Veltloor 400kV S/c line	765/400kV Maheshwaram ICT 1	1	ISTS	816	884	850 (Twin Moose)	104%

High loading on Pugalur New – Karur 400kV D/c (Quad) D/c line is observed (under N-1) in the high RE scenario wherein Southern Region is exporting power to NEW Grid and Raigarh – Pugalur HVDC is considered in reverse mode operation. In this case, entire potential has been considered at Karur PS. However, CTU has received stage-II/LTA application for 420 MW in Karur area. Therefore, measures to control overloading of the line would be planned upon realization of the entire RE potential at Karur PS.

With regard to overloading of Raichur – Vellore 400kV line, reconductoring of the transmission line with HTLS conductor was agreed in the 15th CMETS-SR held on 30.01.2023.

In addition, following STU lines were observed to be loaded beyond 90% of thermal rating under N-1 contingency in the ISTS Rolling Plan 2027-28 timeframe (Interim Report):

(All Fig in MVA)

Sl. No.	Name of the Line	Contingency	Scenario No.	Owner	Base case Loading	Loading under N-1	Rating	% Loading
1	Maheshwaram – Maheshwaram TS 400kV D/c line	Maheshwaram – Maheshwaram TS 400kV one ckt	1, 7	TSTRANSCO	1380	2677	2186 (Quad Moose)	122
2	Mamidipally – Maheshwaram TS 400kV D/c line	Mamidipally – Maheshwaram TS 400kV one ckt	1	TSTRANSCO	582	905	850 (Twin Moose)	106
3	Vizag Pool – Hinduja 400kV D/c line	Vizag Pool – Hinduja 400kV one ckt	5	APTRANSCO	453	869	850 (Twin Moose)	102

High loading of Vizag Pool – Hinduja 400kV D/c line is observed (under N-1) during high generation at Hinduja and low generation at Simhadri generation complex which is a rare event.

High loading of Maheshwaram – Maheshwaram TS 400kV (Quad) D/c line is observed (under N-1) during low internal generation of Telangana and high solar dispatch at Bidar. TSTRANSCO has planned the scheme to control fault level of Maheshwaram TS substation in which they have also proposed the fault limiting reactors in the Maheshwaram – Maheshwaram TS 400kV (Quad) D/c line. The scheme shall also relieve the overloading issue of Maheshwaram – Maheshwaram TS 400kV (Quad) D/c line and Mamidipally – Maheshwaram TS 400kV D/c line.

6.5.2 Measures for controlling overloading of Transformers

11 nos. of ICTs in ISTS were observed to be loaded beyond 90% of thermal rating under N-1 contingency as per the analysis carried out in the ISTS Rolling Plan 2027-28 timeframe (Interim Report). Actions taken for mitigating the overloading of ICTs/ suggested measures are mentioned below:

(All Fig in MVA)

Sl. No.	Name of the Element	Scenario No.	Owner	Base Case Flow	Loading of ICT under N-1	% Loading	Rating (MVA)	Remark
1.	765/400kV, 3x1500 MVA Kurnool-III ICTs	1 & 4	ISTS	1355	1927	128%	1500	With commissioning of RE generation at Kurnool & Anantpur REZ, Augmentation of Kurnool-III with 4 th 1500 MVA ICT would be required. The same would be planned upon materialization of the RE potential.
2.	765/400kV, 2x1500 MVA Maheshwaram ICTs	1 & 7	ISTS	1200	1612	107 %	1500	765/400kV, 1x1500 MVA (3 rd) ICT at Maheshwaram has been agreed in the 14 th CMETS-SR held on 26.12.2022.
3.	400/220kV, 4X1500 MVA Koppal-II ICTs	8 & 9	ISTS	1148	1758	117%	1500	Suitable actions towards augmentation of transformation capacity would be taken on materialization of RE potential at Koppal-II.
4.	765/400kV, 2X1500 MVA Tuticorin PS ICTs	2 & 5	ISTS	881	1500	100 %	1500	In the joint studies meeting held on 21-22 Feb 2023 at SRPC, Transmission scheme for evacuation of power from Kudankulam unit 3 & 4 and unit 5 & 6 was finalized. As part of the same, upgradation of Tuticorin PS at rated voltage of 765kV with 3X1500 MVA ICTs was also agreed. The same has been considered in RP 2027-28 files.

Sl. No.	Name of the Element	Scenario No.	Owner	Base Case Flow	Loading of ICT under N-1	% Loading	Rating (MVA)	Remark
5.	400/220kV, 4X500 MVA Koppal-II ICTs	8 & 9	ISTS	433	580	116%	500	Suitable actions towards augmentation of transformation capacity would be taken on materialization of RE potential at Koppal-II.
6.	400/230kV, 2x250 MVA Neyveli TS-II ICTs	1, 2, 3, 4, 5, 6, 7, 8	ISTS	252	297	118%	250	Issue of high transformer loading has been highlighted earlier also. Site visit is required to find out the space for replacement of 2X250 MVA ICTs with 2X500 MVA.
7.	400/220kV, 4X500 MVA Gadag-II ICTs	8 & 9	ISTS	408	547	109%	500	Suitable actions towards augmentation of transformation capacity would be taken on materialization of RE potential at Gadag-II.
8.	400/220kV, 2x315 MVA + 1x500 MVA Trichy ICTs	6, 7, 8	ISTS	226	320	102%	315	Transformation capacity augmentation would be planned in consultation with STU.
9.	400/220kV, 5x500 MVA Koppal ICTs	2 & 5	ISTS	397	496	99%	500	With commissioning of complete RE potential at Koppal, Augmentation of Koppal with 1X500 MVA ICT would be required. The same would be planned upon materialization of the RE potential.
10.	400/220kV, 2x315 MVA + 1X500 MVA Cuddapah ICTs	7	ISTS	224	308	98%	315	High RE generation at Anantapur is causing overloading of ICTs. ICT augmentation would be planned upon materialization of the RE potential.
11.	400/220kV, 2x315 MVA + 1X500 MVA Hiriyur ICTs	1	ISTS	197	287	91%	315	Injection of KPTCL RE generation at Hiriyur is causing overloading of ICTs. Actions may be taken by KPTCL to avoid excessive RE injection to ISTS.

6.5.3 Measures for controlling over-voltage

As per the voltage analysis carried out in ISTS Rolling Plan 2027-28 timeframe (Interim Report), following 765 kV and 400 kV ISTS buses were having issue of high voltage (voltage more than 1.05 pu):

Sl. No.	Bus Name	Voltage Level (kV)	Owner	Max (pu)	Scenario
1.	Maheshwaram	765	ISTS	1.06	3 & 6
2.	Nizamabad	765	ISTS	1.05	3
3.	Bidar	765	ISTS	1.05	3, 6, 9
4.	Cudappah	765	ISTS	1.05	3
5.	C Peta	765	ISTS	1.05	3
6.	Srikakulam	765	ISTS	1.05	7
7.	Bidar	400	ISTS	1.05	3
8.	Cuddapah	400	ISTS	1.05	3

Over-voltage studies have been carried out and it has been observed that bus voltages in the ISTS are within the limits with addition of one 1x330 MVAR Bus Reactor at 765kV Nizamabad. Requirement of adequate reactive compensation at above buses would be finalized in consultation with SR Constituents.

6.5.4 Measures for controlling Short Circuit

As per the short circuit analysis carried out in ISTS Rolling Plan 2027-28 timeframe (Interim Report), 19 nos. of substations (2 nos. of 765kV substations and 17 nos of 400kV substations of ISTS) are having fault level more than designed capacity in the Region. However, 765kV Kurnool, 400kV Maheshwaram PG, 400kV Kurnool New, 400kV Tirunelveli, 400kV Udumalpet, 400kV Narendra New, 400kV Dharmapuri and 400kV Khammam violates the design fault level by more than 5%. Details of substations having high fault level is given below:

(All Fig in kA)

Sl. No.	Substation Name	Owner	Scenario No.	Highest Fault level	Designed Rating
1	765kV Kurnool	POWERGRID	All	43	40
2	765kV Maheshwaram	POWERGRID	4, 5, 6, 7, 8	41	40
3	400kV Maheshwaram PG	POWERGRID	2, 3, 5, 6, 7, 8, 9	67	63
4	400kV Kurnool New	POWERGRID	All	61	50
5	400kV Narendra New	POWERGRID	5, 6, 8	53	50
6	400kV Dharmapuri	POWERGRID	All	53	50

Sl. No.	Substation Name	Owner	Scenario No.	Highest Fault level	Designed Rating
7	400kV Madhugiri	POWERGRID	4, 7	52	50
8	400kV Kudgi	NTPC	5, 6, 8	50	50
9	400kV Tirunelveli	POWERGRID	All	49	40
10	400kV Udumalpet	POWERGRID	All	49	40
11	400kV Khammam	POWERGRID	2, 3, 5, 6, 7, 8, 9	43	40
12	400kV Pugalur	POWERGRID	2, 3, 5, 6, 8	42	40
13	400kV Ramagundam	NTPC	2, 3, 4, 5, 6, 7, 8, 9	42	40
14	400kV Hyderabad	POWERGRID	2, 3, 5, 6, 7, 8, 9	41	40
15	400kV Salem	POWERGRID	5, 6, 8	41	40
16	400kV Kudankulam	NPCIL	9	41	40
17	400kV Simhadri-I	NTPC	9	41	40
18	400kV Simhadri-II	NTPC	9	41	40
19	400kV Bidadi	POWERGRID	7, 8	40	40

TSTRANSCO has planned the scheme to control fault level of Maheshwaram TS substation. It is expected that bus splitting of Maheshwaram TS substation would resolve the short circuit issue of Maheshwaram (PG) & Kurnool substations. CTU is carrying out detailed system studies for controlling the short circuit level of ISTS buses. The schemes for controlling fault levels would be finalized in a separate joint studies meeting with Southern Region Constituents. After finalization, the schemes would be deliberated in the CMETS-SR.

6.6 System Studies Results and Analysis

Based on the load-generation scenarios as elaborated in section 6.3, various system studies have been carried out in PSSE. Planned/ Under implementation Transmission system that are expected to be commissioned in 2027-28 timeframe are considered for conducting these studies. Further, Govt. of India has set a target of 500 GW generation capacity from non-fossil fuel resources by 2030. In this direction to achieve the target of Govt. of India, MNRE has identified additional 181.5 GW RE potential in the States of Andhra Pradesh, Telangana, Karnataka, Rajasthan, Madhya Pradesh and Tamil Nadu (Offshore). Out of the identified 181.5 GW Potential, 86 GW RE Potential is identified in the State of Andhra Pradesh (51 GW), Telangana (13 GW), Karnataka (17 GW) and Tamil Nadu (5 GW: Offshore) in Southern Region. The transmission system for integration of 181.5 GW RE Potential has been identified by CEA and a report on Transmission System for Integration of over 500 GW RE Capacity

has been published by CEA on 07.12.2022. In the report, implementation of transmission system has been phased out in 3 parts; Phase-I by March 2025, Phase-II by December 2027 and Phase-III by December 2030. Therefore, complete phase-I & phase-II potential and associated transmission system has also been considered in the PSSE files prepared for Rolling Plan of 2027-28 timeframe. Off Shore wind potential in Tamil Nadu has not been considered in the files.

System studies have been conducted on these files prepared for 9 scenarios. Results of these studies were analysed and the same are deliberated below-

6.6.1 Power Flow Analysis

a) Transmission Lines

In the base case file prepared for 2027-28 timeframe, 4 nos. of 765kV and 6 nos. of 400 kV lines are having loading more than 70% of the thermal limit of the line. Scenarios where loading is more than 70% of rating and maximum loading obtained on these transmission lines in the simulation studies are tabulated below at **Table 6-7**.

Table 6-7: Transmission Lines Loading in the Base Cases

(All Fig in MVA)

Sl. No.	Name of the Line	Scenario No.	Owner	Maximum Loading	Rating
1.	Cuddapah-II – Cuddapah 765kV D/c line	1 & 4	ISTS	2706	3500
2.	Kurnool-III – Maheshwaram 765kV D/c line	1 & 4	ISTS	3071	3500
3.	Anantpur - Cuddapah 400kV D/c line	1, 4, 7	ISTS	1941	2186 (Quad Moose)
4.	Maheshwaram - Hyderabad 400kV S/c line	1, 2, 3, 4, 5, 6, 7	ISTS	1689	850 (Twin Moose)
5.	Cuddapah – Chittoor 400kV S/c line	1, 2, 4, 7	ISTS & STU (AP)	1101	850 (Twin Moose)
6.	Cuddapah – N Sagar 400kV D/c line	1 & 4	ISTS	728	850 (Twin Moose)
7.	Malekottiyar – Thiruvalem 400kV D/c line	1, 4, 7	ISTS	696	850 (Twin Moose)
8.	SP Budur – SV Chatram 400kV S/c line	7	ISTS	727	850 (Twin Moose)
9.	Kurnool – Srisailam LB 400kV S/c line	1, 4, 7	APTRANSCO	1220	850 (Twin Moose)
10.	VTPS-IV – Vijaywada PG 400kV S/c line	4 & 7	APTRANSCO	812	850 (Twin Moose)
11.	Somanhally – Bidadi 400kV D/c line	7	KPTCL	608	850 (Twin Moose)

b) Transformers

In the base case file prepared for 2027-28 timeframe, transformers at 3 nos. of 765/400 kV substations and 2 nos. of 400/220kV substations are having loading more than 70% of the ICT rating. Scenarios where loading is more than 80% of rating and maximum loading hit by these transformers in the simulation studies are tabulated below at Table 6-8.

Table 6-8: Transformers Loading in the Base Cases

(Max Loading in MVA)

Sl. No.	Name of the Element	Scenario No.	Owner	Maximum Loading	Rating (MVA)
1.	765/400kV, 6x1500 MVA Kurnool-III ICTs	1 & 4	ISTS	1331	1500
2.	765/400kV, 3x1500 MVA Maheshwaram ICTs	1, 4, 7	ISTS	1349	1500
3.	765/400kV, 4x1500 MVA Nizamabad ICTs	1 & 4	ISTS	1257	1500
4.	765/400kV, 6x1500 MVA Nizamabad – II ICTs	1 & 4	ISTS	1164	1500
5.	765/400kV, 6x1500 MVA Koppal – II ICTs	1, 2, 4, 5	ISTS	1161	1500
6.	400/220kV, 1x500 MVA Cuddapah ICT	1, 4, 7	ISTS	467	500
7.	400/220kV, 5X500 MVA Koppal ICTs	2, 5, 6	ISTS	409	500
8.	400/220kV, 3x500 MVA Maheshwaram TS ICTs	1 & 4	TSTRANSCO	380	500
9.	400/220kV, 2x315 MVA Cuddapah ICTs	1, 4, 7	ISTS	291	315
10.	400/220kV, 3x315 MVA N Sagar ICTs	1, 4, 7	ISTS	249	315
11.	400/230kV, 3x315 MVA Salem ICTs	1	TANTRANSCO	229	315
12.	400/230kV, 2x250 MVA Neyveli TS-II ICTs	4	NLC	192	250

c) Voltage Analysis

PU voltages of all 765 kV and 400 kV buses were observed in all the nine scenarios prepared for 2027-28 timeframe. Maximum and minimum voltage of each bus were identified from the bus voltages in the nine number of scenarios. From the simulation results, generally it was observed that no bus in Southern Region is having issue of under voltage.

Further, 765kV & 400kV buses having voltage more than 1.05 pu are Tabulated at **Table 6-9**.

Table 6-9: Buses having more than 1.05 pu Voltage in SR

Sl. No.	Bus Name	Voltage Level (kV)	Owner	Max (pu)	Scenario
1.	Uppur	765	TANTRANSCO	1.05	7
2.	Virudhnagar	765	TANTRANSCO	1.06	7
3.	Muddunur	400	APTRANSCO	1.08	2, 6, 9
4.	Raidurg	400	TSTRANSCO	1.07	2, 3, 5, 6
5.	Kethireddypally	400	TSTRANSCO	1.07	6
6.	Suryapet	400	TSTRANSCO	1.06	6
7.	Malkaram	400	TSTRANSCO	1.06	6
8.	Chouttuppall	400	TSTRANSCO	1.06	6
9.	Kalikiri	400	APTRANSCO	1.06	6 & 9

Sl. No.	Bus Name	Voltage Level (kV)	Owner	Max (pu)	Scenario
1.	Uppur	765	TANTRANSCO	1.05	7
2.	Virudhnagar	765	TANTRANSCO	1.06	7
10.	Ramagundam STP	400	NTPC	1.06	6
11.	Shankarpally	400	TSTRANSCO	1.06	6
12.	Julurupadu	400	TSTRANSCO	1.05	6
13.	Janagaon	400	TSTRANSCO	1.05	6
14.	Yadadri TPP	400	TSTRANSCO	1.05	6
15.	Damaracharla	400	TSTRANSCO	1.05	6
16.	Koth-VI	400	TSTRANSCO	1.05	6
17.	Koth - VII	400	TSTRANSCO	1.05	6
18.	Mamidipally	400	TSTRANSCO	1.05	6
19.	Maheshwaram Sec B	400	TSTRANSCO	1.05	6
20.	Talaricharla	400	APTRANSCO	1.05	9
21.	Hindupur	400	APTRANSCO	1.05	9
22.	Urvakonda	400	APTRANSCO	1.05	9
23.	Kondapuram	400	APTRANSCO	1.05	9
24.	Warangal	400	PGCIL	1.05	6
25.	Khamman	400	PGCIL	1.05	6

High voltages have been observed during night off-peak hours due to less loading in 765kV & 400kV lines emanating from these substations and during solar max scenarios due to non-availability of thermal generation. Further, few substations of Telangana are facing issue of over voltage during the period when Lift Irrigation loads are not in operation. Generally, it is observed that reactive compensation proposed under STU is not implemented as per the timelines by them and reactive power is injected from STU network. For mitigating the over voltages at state network buses, STUs are required to work out adequate reactive compensation and suitable mechanism for capacitors at lower voltage levels.

6.6.2 Contingency Analysis

Contingency analysis has been performed on all the 765 kV & 400kV transmission lines, and 765/400 kV & 400/220 kV transformers to ascertain the loading levels under outage of any other 765 kV or 400 kV transmission element. Results of the analysis are discussed below:

a) Transmission Lines

ISTS lines loaded beyond 90% of thermal rating under N-1 contingency are summarized below at **Table 6-10**.

Table 6-10: ISTS Transmission lines not meeting N-1 Criteria in SR

(All Fig in MVA)

Sl. No.	Name of the Line	Contingency	Scenario No.	Owner	Base case Loading	Loading under N-1	Rating	% Loading
1.	Cuddapah-II – Cuddapah 765kV D/c line	Cuddapah-II – Cuddapah 765kV one ckt	1, 2, 4, 7	ISTS	2706	4601	3500 (Hexa Zebra)	131
Remark: Power from Cuddapah II & Anantpur 2 is getting pooled at Cuddapah and causing overloading of Cuddapah – Cuddapah 2 765kV D/c line.								
2.	Kurnool-III – Kurnool 765kV D/c line	Kurnool-III – Kurnool 765kV one ckt	1 & 4	ISTS	2676	3635	3500 (Hexa Zebra)	104
3.	Kurnool III – Maheshwaram 765kV D/c line	Kurnool III – Maheshwaram 765kV one ckt	1 & 4	ISTS	3071	4112	3500 (Hexa Zebra)	117
Remark: Integration of 4.5 GW additional potential (part of 181.5 GW) at Kurnool-III is causing overloading of Kurnool – Kurnool-III 765kV D/c line and Kurnool-III – Maheshwaram 765kV D/c line.								
4.	Maheshwaram – Bidar 765kV D/c line	Maheshwaram – Bidar 765kV one ckt	4	ISTS	2125	3361	3500 (Hexa Zebra)	96
Remark: Some part of 4 GW potential at Kurnool-IV (part of 181.5 GW) is pushing towards Bidar and causing overloading of Maheshwaram – Bidar 765kV D/c line.								
5.	Anantpur - Cuddapah 400kV (Quad) D/c line	Cuddapah – Anantpur 400kV (Quad) one ckt	1, 4, 7	ISTS	1980	2731	2186 (Quad Moose)	103
Remark: Major portion RE power at Anantpur (7 GW) is getting evacuated through Anantpur - Cuddapah 400kV D/c line and causing overloading of the line.								
6.	Koppal PS-II – Davangere 400kV D/c line	Koppal PS-II – Davangere 400kV one ckt	2 & 5	ISTS	1117	2255	2186 (Quad Moose)	102
Remark: This is being observed in Sc-2 wherein wind dispatch is 75% and BESS is also in discharging mode.								
7.	Pugalur New – Karur 400kV D/c line	Pugalur New – Karur 400kV one ckt	1, 2, 5, 6	ISTS	1330	2284	2186 (Quad Moose)	104
Remark: In high RE scenario wherein Southern Region is exporting power to NEW Grid and Raigarh – Pugalur HVDC is considered in reverse mode, more power rush towards Karur. This causes overloading of Pugalur New – Karur 400kV D/c line.								
8.	Gadag-II – Koppal-II 400kV D/c line	Gadag-II – Koppal-II 400kV one ckt	2 & 5	ISTS	1108	2210	2186 (Quad Moose)	101
Remark: This is being observed in Sc-2 wherein wind dispatch is 75% and BESS is also in discharging mode.								
9.	Nizamabad – Dichipally 400kV D/c line	Nizamabad – Dichipally 400kV one ckt	1 & 4	ISTS	1158	2259	2186 (Quad Moose)	102
Remark: Some portion of RE power getting pooled at 765kV Nizamabad is going down at 400kV and major power from 400kV Nizamabad getting evacuated through Dichipally line.								
10.	Cuddapah - N Sagar 400kV D/c line	Cuddapah - N Sagar –400kV one ckt	1 & 4	ISTS	728	865	850 (Twin Moose)	102
Remark: Integration of 3.5 GW additional potential (part of 181.5 GW) at Anantpur causing overloading of line.								

Sl. No.	Name of the Line	Contingency	Scenario No.	Owner	Base case Loading	Loading under N-1	Rating	% Loading
11.	Maheshwaram - Hyderabad 400kV S/c line	Maheshwaram – Warangal 765kV one ckt	1, 3, 4, 5, 7	ISTS	1680	1770	850 (Twin Moose)	208
Remark: RE power going down at 400kV from 765kV Maheshwaram combined with low internal thermal generation including Ramagundam is causing overloading of Maheshwaram – Hyderabad line.								
12.	Somanhally – Bidadi 400kV D/c line	Somanhally – Bidadi 400kV one ckt	1, 4, 7	ISTS	609	1040	850 (Twin Moose)	122
Remark: During peak RE scenario of Karnataka, high loading is observed on Somanhally – Bidadi D/c for some time. Line does not comply N-1 criteria during this time.								
13.	Thiruvalem – Malekottiyar 400kV D/c line	Thiruvalem – Malekottiyar 400kV one ckt	1, 4, 7	ISTS	709	920	850 (Twin Moose)	108
Remark: During Low thermal generation (VTPS, North Chennai) in Chennai area, loads at Malekottiyar is being met through this line & is causing overloading of line. Suitable strengthening would be planned based on the operational feedback.								
14.	Cuddapah – Chittoor 400kV S/c line	Cuddapah – N Sagar 400kV one ckt	1, 4, 7	ISTS & APTR ANSCO	1101	1134	850 (Twin Moose)	133
Remark: High loading of Cuddapah – Chittoor 400kV S/c line is very predominant during peak RE scenario. Reconductoring of transmission line with higher ampacity conductor would be planned in upcoming CMETS-SR in coordination with SRLDC & APTRANSCO.								
15.	Karaikudi – Trichy 400kV S/c line	Trichy – Madurai 400kV S/c	4	ISTS	583	777	850 (Twin Moose)	91
Remark: During peak RE scenario and low generation in Neyveli complex, power rush from Karaikudi to Trichy under N-1 of Trichy Madurai 400kV line and this causes overloading of line.								

In the rolling plan PSSE files of 2027-28 timeframe, entire Phase-I & Phase-II potential of additional 181.5 GW RE capacity by 2030 has been considered. Overloading of transmission lines and ICTs are observed at locations where this potential is getting pooled. The main cause of overloading of transmission lines is mentioned in the remark below the lines. However, these loadings of transmission lines may significantly differ in case of deferment in materialisation of RE generations in SR grid. Therefore, measures to control overloading of the transmission system part of 181.5 GW RE potential would be planned based on materialization of the RE potential.

Further, STU lines loaded beyond 90% of thermal rating under N-1 contingency are summarized below at **Table 6-11**.

Table 6-11: STU Transmission lines not meeting N-1 Criteria in SR

(All Fig in MVA)

Sl. No.	Name of the Line	Contingency	Scenario No.	Owner	Base case Loading	Loading under N-1	Rating	% Loading
1.	Kurnool AP – Srisalem LB 400kV S/c line	Cuddapah – C Peta 765kV one ckt	1 & 4	APTRAN SCO	1220	1286*	850 (Twin Moose)	151
2.	Vijayawada PG – VTPS IV 400kV S/c line	Vijayawada PG – Khammam 400kV line	4 & 7	APTRAN SCO	810	925#	850 (Twin Moose)	109
3.	Vijaywada AP – Thalayapalem 400kV D/c line	Vijaywada AP – Thalayapalem 400kV one ckt	1 & 4	APTRAN SCO	517	905\$	850 (Twin Moose)	106
4.	Vijaywada AP – Buruguban LI 400kV D/c line	Vijaywada AP – Buruguban LI 400kV one ckt	1 & 4	APTRAN SCO	447	817	850 (Twin Moose)	96
5.	Vemagiri PG – Vemagiri AP 400kV D/c line	Vemagiri PG – Vemagiri AP 400kV one ckt	1 & 7	APTRAN SCO + PGCIL	657	1021	1093 (Twin Moose)	93
6.	Hoody – Devanhally 400kV D/c line	Hoody – Devanhally 400kV one ckt	4 & 7	KPTCL	511	899	850 (Twin Moose)	105

* Major portion of RE power pooled at Kurnool New from Kurnool-III RE potential and Greenko generation is getting evacuated from Kurnool New – Kurnool AP 400kV D/c line and this is increasing the loading of Kurnool AP – Srisalem LB 400kV S/c line.

During peak load scenario, load around Vijaywada area is fed mostly from VTPS-IV generation and under N-1 of Vijaywada – Khammam 400kV line, even more power gets drawn through VTPS-IV – Vijaywada 400kV line.

\$ When thermal generation of VTPS-IV generation is not available, load of Vijaywada area and Lift irrigation load of Andhra get fed from Vijaywada AP through Vijaywada AP – Thalayapalem 400kV D/c line.

b) Transformers

ISTS ICTs loaded beyond 90% of MVA rating under N-1 contingency are summarized below at

Table 6-12.

Table 6-12: ISTS ICTs not meeting N-1 Criteria in SR

(All Fig in MVA)

Sl. No.	Name of the Element	Scenario No.	Owner	Base Case Flow	Loading of ICT under N-1	% Loading	Rating (MVA)
1.	765/400kV, 3x1500 MVA Maheshwaram ICTs	1, 4, 7	PGCIL	1356	1756	117	1500
2.	765/400kV, 6x1500 MVA Kurnool-III ICTs	1&4	PGCIL	1351	1605	107	1500
3.	765/400kV, 2x1500 MVA C Peta ICTs	1&4	PGCIL	1080	1642	109	1500
4.	765/400kV, 4x1500 MVA Nizamabad ICTs	1&4	PGCIL	1262	1578	105	1500
5.	765/400kV, 2x1500 MVA Warangal ICTs	1	PGCIL	968	1527	102	1500
6.	765/400kV, 6x1500 MVA Koppal-II PS ICTs	4	ISTS	1178	1415	94	1500
7.	765/400kV, 2x1500 MVA Vemagiri ICTs	1	PGCIL	902	1407	94	1500
8.	400/220kV, 2x315 + 1X500 MVA MVA Cuddapah ICTs	1, 4, 7	PGCIL	464	561	112	500
				292	402	128	315
9.	400/230kV, 2X500 MVA NNTPS ICTs	7 & 8	NLC	375	517	103	500
10.	400/220kV, 5x500 MVA Koppal PS ICTs	2, 5, 6	Renew	412	515	103	500
11.	400/220kV, 3x315 MVA N Sagar ICTs	1 & 4	PGCIL	252	301	96	315
12.	400/230kV, 3x315 MVA Hosur ICTs	1	PGCIL	215	290	92	315
13.	400/230kV, 2x315 MVA Trichy ICTs	8	PGCIL	202	284	90	315
14.	400/230kV, 2x250 MVA Neyveli TS ICTs	4	NLC	195	229	91	250

Requirement of additional transformation augmentation wherever necessary would be planned subsequently in coordination with respective STUs.

STU ICTs loaded beyond 90% of MVA rating under N-1 contingency are summarized below at **Table 6-13**.

Table 6-13: STU ICTs not meeting N-1 Criteria in SR

(All Fig in MVA)

Sl. No.	Name of the Element	Scenario No.	Owner	Base Case Flow	Loading of ICT under N-1	% Loading	Rating (MVA)
1.	765/400kV, 2x1500 MVA Ariyalur ICTs	1, 2, 7	TANTRANSCO	1108	1704	114	1500
2.	765/400kV, 2x1500 MVA Coimbatore ICTs	7	TANTRANSCO	1070	1683	112	1500

Sl. No.	Name of the Element	Scenario No.	Owner	Base Case Flow	Loading of ICT under N-1	% Loading	Rating (MVA)
3.	400/220kV, 2x315 MVA Edaman ICTs	1, 4, 5, 7, 8	KSEB	261	354	112	315
4.	400/220kV, 2X500 MVA Jagalur ICTs	1 & 4	KPTCL	348	533	107	500
5.	400/220kV, 2X500 MVA Peenya ICTs	7	KPTCL	355	512	102	500
6.	400/220kV, 3x500 MVA Maheshwaram TS ICTs	1 & 4	TSTRANSCO	388	491	98	500
7.	400/230kV, 2X315 MVA Kamuthi ICTs	1, 4, 7	TANTRANSCO	206	419	132	315
8.	400/220kV, 2X315 MVA Kanarpatty ICTs	1 & 4	TANTRANSCO	165	330	105	315
9.	400/110kV, 2X200 MVA Thenampatty ICTs	1, 4, 7	TANTRANSCO	163	323	162	200
10.	400/110kV, 2X200MVA Cuddalore ICTs	All	TANTRANSCO	227	321	161	200
11.	400/110kV, 2X200 MVA Velalavidu ICTs	1, 2, 3, 4, 5, 6, 7, 8	TANTRANSCO	216	312	156	200
12.	400/110kV, 2X200 MVA Kamuthi ICTs	1, 4, 7	TANTRANSCO	180	304	152	200
13.	400/110kV, 2X200 MVA Arni ICTs	1, 2, 3, 4, 5, 6, 7, 8	TANTRANSCO	209	286	142	200
14.	400/110kV, 2X200 MVA Palavadi ICTs	1, 2, 4, 5, 8	TANTRANSCO	180	268	134	200
15.	400/110kV, 2X200 MVA Kayathar ICTs	1, 2, 3, 4, 5, 6	TANTRANSCO	152	258	129	200
16.	400/110kV, 3X200MVA Salem ICTs	1, 2, 4, 5, 7	TANTRANSCO	208	258	129	200
17.	400/110kV, 2X200 MVA Alagarkoil ICTs	1, 2, 4, 5, 7, 8	TANTRANSCO	174	244	122	200
18.	400/110kV, 3X100 MVA Rasipalayam ICTs	2, 3, 5, 6	TANTRANSCO	85	114	114	100
19.	400/110kV, 2X200 MVA Edayarpalayam ICTs	7 & 8	TANTRANSCO	182	216	108	200
20.	400/110kV, 3x200 MVA Tappakun ICTs	2	TANTRANSCO	123	183	92	200

Sl. No.	Name of the Element	Scenario No.	Owner	Base Case Flow	Loading of ICT under N-1	% Loading	Rating (MVA)
21.	400/110kV, 2x200 MVA S P Badur ICTs	7	TANTRANSCO	129	190	95	200

From above, it is observed that one ICT in Kerala, one ICT in Telangana, 2 nos. of ICT in Karnataka and 14 nos. of ICT in Tamil Nadu are not complying N-1 criteria in 2027-28 timeframe. Some of them are violating the limits in present timeframe also and are continuously flagged by GRID INDIA in their Operational Feedback. Most of these ICTs of TANTRANSCO are hitting more than 120% loading under N-1 Contingency and some of these ICTs are limiting the Available Transfer Capability of the State. Therefore, STUs are required to take immediate measures to mitigate this issue of high transformer loading.

6.6.3 Short Circuit Analysis

Short circuit level was calculated for all 765 and 400 kV buses of Southern Region and buses having fault level more than the design rating under any scenario were identified. From analysis, it is emerged that 5 nos. of 765kV substations and 17 nos of 400kV substations in SR are having fault level more than designed capacity. Owner wise distribution of these buses and scenarios in which these buses are crossing the design fault level are shown in **Figure 6-6**.

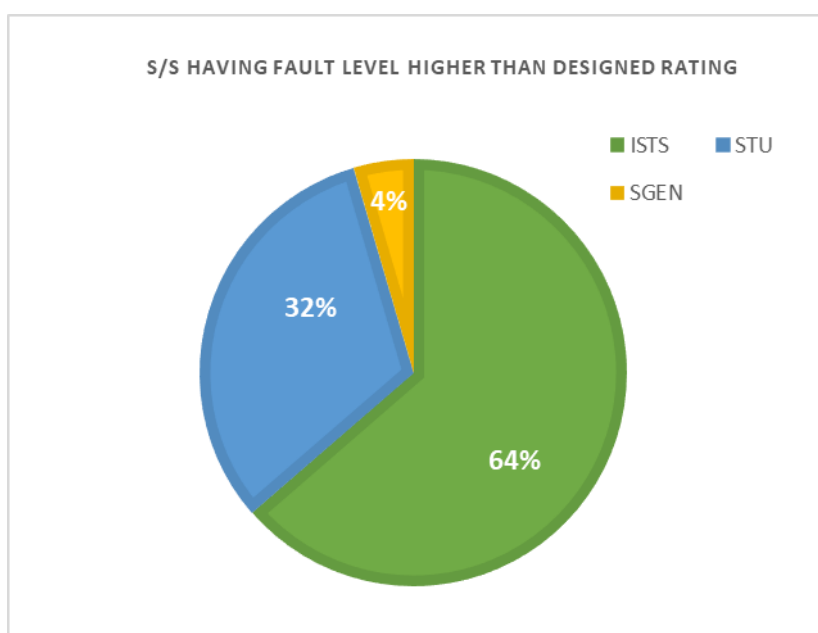

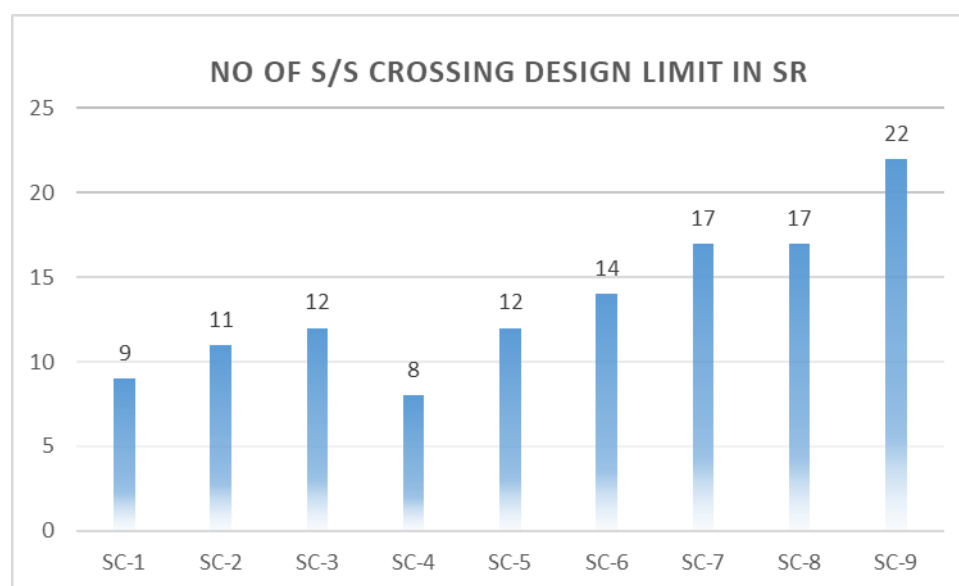

Figure 6-6: Substations crossing the design limit in SR

Details of the ISTS buses exceeding design fault level under any scenario are tabulated below at **Table 6-14**.

Table 6-14: ISTS Buses Exceeding Designed Fault Level in SR

(All Fig in kA)

Sl. No.	Substation Name	Owner	Scenario No.	Highest Fault level	Design Rating
1.	765kV Kurnool	ISTS	All	52	40
2.	765kV Cuddapah	ISTS	2, 3, 5, 6, 7, 8, 9	43	40
3.	765kV Nizamabad	ISTS	All	44	40
4.	765kV Maheshwaram	ISTS	All	51	40
5.	765kV Raichur	ISTS	3, 6, 7, 8, 9	41	40
6.	400kV Kurnool New	ISTS	All	55	50
7.	400kV Tuticorin PS	ISTS	9	50	50
8.	400kV Tirunelveli	ISTS	All	56	40
9.	400kV Udumalpet	ISTS	All	50	40
10.	400kV Pugalur	ISTS	5, 6, 8, 9	43	40
11.	400kV Hyderabad	ISTS	7, 8, 9	42	40
12.	400kV Ramagundam	NTPC	7, 8, 9	42	40
13.	400kV Khammam	ISTS	7, 8, 9	41	40
14.	400kV Bidadi	ISTS	7, 9	41	40
15.	400kV Madurai	ISTS	9	41	40

From the above, it can be seen that 765kV Kurnool, 765kV Cuddapah, 765kV Nizamabad, 765kV Maheshwaram, 400kV Pugalur, 400kV Kurnool New, 400kV Tirunelveli, 400kV Udumalpet, 400kV Hyderabad and 400kV Ramagundam violates the design fault level by more than 5%. CTU is carrying out detailed system studies for controlling the short circuit level of

ISTS buses. The schemes for controlling fault levels would be finalized in a separate joint studies meeting with Southern Region Constituents. After finalization, the schemes would be deliberated in the CMETS-SR.

Further, STU buses exceeding the substation design fault level under different scenario are mentioned at **Table 6-15**.

Table 6-15: STU Buses Exceeding Designed Fault Level in SR

(All Fig in kA)

Sl. No.	Substation Name	Owner	Scenario No.	Highest Fault level	Designed Rating
1.	400kV Kurnool	AP	All	53	40
2.	400kV Vemagiri	AP	2, 3, 5, 6, 8, 9	46	40
3.	400kV Dichipally	TSTRANSCO	All	52	40
4.	400kV Gajwel	TSTRANSCO	7, 8, 9	42	40
5.	400kV Neelmangala	KPTCL	All	44	40
6.	400kV Raichur	KPTCL	6, 7, 8, 9	41	40
7.	400kV Udangudi	TANTRANSCO	9	40	40

STUs are also required to take necessary actions such as bus splitting, bypassing of lines, fault limiting reactors etc to resolve the issue of high fault level at their buses.

Page intentionally left blank

Chapter 7: Eastern Region

Eastern Region is stretching from Sikkim in the southern Himalayas to the coast of the Bay of Bengal. In this region, the states of Bihar and West Bengal lie on the Indo - Gangetic plain and Jharkhand lies on the Chota-Nagpur Plateau. Odisha lies on the Eastern Ghats and the Deccan Plateau. The region is bounded by Bhutan & Nepal in the north, the states of Uttar Pradesh & Chhattisgarh on the west, the state of Andhra Pradesh in the south and the state of Assam and country of Bangladesh in the east. It has a very important narrow corridor between international border of Nepal and Bangladesh, called “Chicken's Neck”, with a size of 18km by 22km, which connects the north Bengal, Sikkim and entire North Eastern Region with the remaining part of National Grid.

The generating stations of Eastern Regions are predominantly concentrated in the coal rich states of Jharkhand, Odisha and West Bengal and hydro generations are concentrated in Sikkim and southern part of Odisha. Eastern Region is also connected to Bhutan for import of power from hydro generations and to Nepal & Bangladesh for export of power.

7.1 Power Supply Scenario as on Feb'23

As on Feb'2023, total Installed Capacity (IC) of Eastern Region was about 34.34 GW and the peak demand met was about 27.22 GW. The state-wise breakup of installed capacity and peak demand is summarised at **Table 7-1** Table 6-1 below.

Table 7-1: Installed Capacity and Peak Demand of ER as on Feb'23

(All Fig in MW)

State	Generation (MW)							Grand Total	Peak Demand (MW)
	Fossil			Non Fossil					
	Thermal	Gas	Total	Nuclear	Hydro	RES* (MNRE)	Total		
Bihar	7055	-	7055	-	110	390	500	7555	6631
Jharkhand	2361	-	2361	-	191	110	301	2662	3428
DVC	8616	80	8696	-	1396	608	2004	10700	1918
Odisha	3027	-	3027	-	186	-	186	3213	6391
West Bengal	4990	-	4990	-	2163	628	2791	7781	9900
Sikkim	12	-	12	-	633	60	693	705	124
Central unallocated	1638	-	1638	-	85	-	85	1723	62
ER	27700	80	27780	-	4764	1795	6560	34339	27218

Source: CEA monthly report

7.2 Envisaged Power Supply Scenario by 2027-28

As per the 20th EPS, Eastern Region demand for 2027-28 timeframe is expected to increase to about 39.85 GW. As per the inputs received from various stakeholders, total installed capacity of Eastern Region for 2027-28 is expected to be about 60.15 GW. The state wise bifurcation of installed capacity and peak demand is summarized below at **Table 7-2**.

Table 7-2: Eastern Region Installed Capacity and Peak Demand (2027-28)

(All Fig in MW)

State	Generation									Peak Demand
	Fossil			Non Fossil				ESS / PSS	Grand Total	
	Thermal	Gas	Total	Nuclear	Hydro	RES	Total			
Bihar	2040	-	2040	-	45	700	745	-	2785	11416
Jharkhand	2820	-	2820	-	130	-	130	-	2950	4048
DVC	-	-	-	-	-	-	-	-	-	4510
Odisha	2490	-	2490	-	2193	403	2596	-	5086	8053
West Bengal	7100	-	7100	-	574	-	574	900	8574	13708
Sikkim	-	-	-	-	14	-	14	-	14	190
Central	25760	-	25760	-	5819	-	5819	-	31579	-
IPP	4150	-	4150	-	5012	-	5012	-	9162	-
ER	44360	-	44360	-	13786	1103	14889	900	60149	39847

There is a growth in peak demand of Eastern Region from present time-frame (2022-23) to 2027-28 with a CAGR of 7.9%. The state wise peak demand growth is given at **Table 7-3**.

Table 7-3: Increase in Peak Demand of Various States of ER

(All Fig in MW)

State	2022-23	2027-28	Increase in demand	CAGR
Bihar	6631	11416	4785	11.5%
Jharkhand	1918	4048	2130	16.1%
DVC	3428	4510	1082	5.6%
Odisha	6391	8053	1662	4.7%
West Bengal	9900	13708	3808	6.7%
Sikkim	124	190	66	8.9%
ER	27218	39847	12629	7.9%

From the above data it is observed that the CAGR growth of peak demand is maximum for Jharkhand (16.1%) and minimum for Odisha (4.7%). The CAGR of demand of ER is about 7.9% which is more than the National Average of 6.9%. However, considering the present demand of OPTCL, it is understood that the peak demand of OPTCL would surpass the EPS projection.

The hydro generations of Bhutan (about 4290MW) and Nepal (900MW) and demand of Bangladesh (1000MW) have been considered in 2027-28 timeframe as a part of Eastern Region for study purpose. A new demand of 1500MW green hydrogen at Paradeep in Odisha has been considered in addition to the EPS demand of Odisha.

7.3 Load Generation Balance for 2027-28 timeframe

In the chapter 3, All India Load Generation Balance (LGB) for identified nine scenarios was prepared as per the methodology finalized in a meeting among CTU, CEA and Grid-India. This section elaborates the Eastern Region Load Generation Balance (LGB) for 2027-28 timeframe. For Eastern Region also, three points on the daily load curve i.e. Solar max (afternoon), Peak load (evening) and Off-peak load (night) for three seasons viz. Monsoon (August), Summer (June) and Winter (February) have been considered.

Load generation balance has been prepared considering the generation despatch factors as mentioned at **Table 7-4** for the 9 scenarios. Further, thermal generators have been despatched as per the merit order.

Table 7-4: Eastern Region Generation Dispatch and Demand Factors

Scenario No & Name	Generation Dispatch Factors			Demand Factors
	Hydro	Solar	Pump storage	
1-Aug Solar Max	70%	80%	-100%	74%
2-Aug Peak Load	90%	0%	60%	91%
3-Aug Night Off Peak	70%	0%	40%	77%
4-Jun Solar Max	70%	85%	-100%	75%
5-Jun Peak Load	90%	0%	50%	85%
6-Jun Night Off Peak	70%	0%	0%	72%
7-Feb Solar Max	30%	90%	-100%	70%
8-Feb Peak Load	60%	0%	60%	78%
9-Feb Night Off Peak	30%	0%	40%	49%

The despatch from thermal generations have been done considering merit order despatch. Based on the LGB, import / export of ER and the inter regional flows through various corridors is summarised in **Table 7-5**. Further, both maximum and minimum is also highlighted in table below.

Table 7-5: Import / Export of Eastern Region

(All Fig in MW)

State / UTs	Import / Export of Eastern Region								
Scenario No	Aug'27 Time Frame			Jun'27 Time Frame			Feb'28 Time Frame		
	1 (Solar Max)	2 (Peak Load)	3 (Off Peak)	4 (Solar Max)	5 (Peak Load)	6 (Off Peak)	7 (Solar Max)	8 (Peak Load)	9 (Off Peak)
ER-NR	-7567	861	-2301	-8557	1376	-4697	-10195	428	-1929
ER-WR	-9643	-6221	-6607	-11858	-6990	-5460	-10085	-1791	-3228
ER-SR	1233	139	-93	-692	552	837	1247	1794	2469
ER-NER	3	-121	-706	-414	-1166	-1263	1103	351	37
ER-B'Desh	1000	1000	1000	1000	1000	1000	1000	1000	1000
ER-Bhutan	-3109	-3974	-3125	-2329	-3993	-3143	-1319	-2668	-1336
ER-Nepal	-861	-1102	-863	-600	-1102	-865	-371	-742	-371
Eastern Region	-18944	-9418	-12695	-23450	-10323	-13591	-18620	-1628	-3358

It can be seen that with the huge penetration of renewables, Eastern Region is net importing region in all the scenarios. Out of these nine scenarios, Scenario-4 and Scenario-8 corresponds to two extreme cases of import requirement of Eastern Region i.e. Maximum import

(23.45GW) and minimum import (1.63GW). In all other scenarios, the import of Eastern Region varies between these two sextremes.

Considering the above LGB for nine scenarios, load flow cases were prepared for 2027-28 timeframe. Detailed system studies have been carried out on the finalized load flow cases. The study results are discussed in subsequent sections.

7.4 ISTS Network Expansion Schemes Evolved from Mar'22 to Feb'23

Various transmission schemes have been discussed/finalized in the Consultative Meeting for Evolution of Transmission System of Eastern Region (CMETS-ER) from March 2022 to February 2023. The brief of all such transmission schemes are tabulated below in **Table 7-6**:

Table 7-6: Approved Transmission Schemes in this Rollnig Plan

Sl. No.	Name of the Transmission Scheme	Expected Timeframe	Tentative Cost (in ₹Cr.)
Bihar			
1.	Eastern Region Expansion Scheme-XXVIII (ERES-XXVIII)	Dec'23	23.27
2.	Fault level control at Patna (POWERGRID) S/s at 400kV level	-	-
West Bengal			
1.	Eastern Region Expansion Scheme-XXXI (ERES-XXXI)	Apr'24	9.56
2.	Eastern Region Expansion Scheme-XXXII (ERES-XXXII)	July'24	25.83
Jharkhand			
1.	Eastern Region Expansion Scheme-XXXI (ERES-XXXI)	Apr'24	25.83
Odisha			
1.	Eastern Region Expansion Scheme-XXIX (ERES-XXIX)	Nov'25	422.23
2.	Eastern Region Expansion Scheme-XXXIV (ERES-XXXIV)	2025-26	2564.24
Sikkim			
1.	Eastern Region Expansion Scheme-XXXIII (ERES-XXXIII)	Nov'24	23.08
2.	Eastern Region Expansion Scheme-XXX (ERES-XXX)	Aug'24	11.64

7.4.1 Bihar

(a) Eastern Region Expansion Scheme-XXVIII (ERES-XXVIII)

During winter season the bus voltage at Biharsharif S/s has reached upto 422kV as per data from ERLDC. Biharsharif substation is being operated in split mode from Mar 2021 onwards. Section-A comprises of 80MVA bus reactor and Section-B comprises of 50MVA+2x125MVA bus reactors. As per the study, with switching of 125MVA bus reactor at Biharsharif Section-A, the bus voltage changes by about 2kV. It is proposed to install new 420kV, 125MVA bus reactor along with associated bay in the Section-A of Biharsharif substation in order to limit voltage rise and also to meet contingency of only one 80MVA bus reactor in that section.

Accordingly, installation of 420kV, 1x125MVA bus reactor along with associated bay at Biharsharif (POWERGRID) S/s in the bus section having 1x80MVA existing bus reactor has been agreed for implemented under ISTS in the 6th CMETS-ER held on 29-04-2022.

The implementation schedule of the scheme would be about 18 months. However, best efforts would be made to commission the reactor at the earliest.

(b) Fault level control at Patna (POWERGRID) S/s at 400kV level

Present fault level of Patna 400kV bus is observed to be about 42kA. With progressive commissioning of new generating units of Barh-1, Buxar, and North Karanpura generation projects and other network expansion schemes around Patna, the same is expected to increase to 48.4kA. The issue of controlling the fault level at Patna (POWERGRID) S/s was discussed in the 9th CMETS-ER meeting wherein it was proposed that in order to limit fault current at 400kV side at Patna S/s, Patna – Barh 400kV D/c (Quad) line (ckt-3 & 4) (68.9km) and Patna – Naubatpur 400kV D/c (Quad) line (25.45km) can be bypassed at Patna S/s from within the substation itself using switching arrangement, so as to form Barh – Naubatpur 400kV D/c (Quad) line. With the proposed bypassing arrangement, the fault level of Patna (POWERGRID) substation at 400kV bus is observed to be reduced from 48.4kA to 36.2kA in 2027-28 timeframe. Accordingly, the following bypassing scheme was agreed in the 14th CMETS-ER held on 29-12-2022:

- Bypassing of Patna – Barh 400kV D/c (Quad) line (ckt-3 & 4) (68.9km) and Patna – Naubatpur 400kV D/c (Quad) line (25.45km) at Patna S/s through the tie breaker, so as to form Barh – Naubatpur 400kV D/c (Quad) line. This would be a normal operating condition.
- The above arrangement would be implemented by POWERGRID in coordination with NTPC and BSPTCL/BGCL. Being an operational matter, ERLDC would provide directions and timeframe for implementation of the same.
- Under exigencies or as per system conditions, and based on instructions from Grid-India/ERLDC, the Patna – Barh 400kV D/c (Quad) line (ckt-3 & 4) and Patna – Naubatpur 400kV D/c (Quad) line, as and when required can be terminated at Patna S/s.

7.4.2 West Bengal

(a) Eastern Region Expansion Scheme-XXXI (ERES-XXXI)

Presently, 1x50MVA line reactor at 400kV Maithon-A end of Maithon-A – Kahalgaon-B ckt-1 is in service. Based on the condition monitoring and residual life assessment by CPRI, this 50MVA line reactor (commissioned in 1991) has completed their useful life. as per the studies, following was observed:

- On charging of Maithon-A – Kahalgaon-B ckt-1 from either end without line reactor, total voltage rise is about 11-12kV.
- In view of current network conditions, charging studies were done with 63MVA line reactor in the subject line, the total rise is observed to be 1-2kV while charging from Kahalgaon-B end and 9-10kV while charging from Maithon-A end.

Accordingly, installation of new 420kV, 1x63MVA line reactor at Maithon-A end of Maithon-A – Kahalgaon-B ckt-1 400kV line along with new 700ohm NGR (with NGR bypass arrangement for operation of line reactor as a bus reactor) was agreed in the 8th CMETS-ER held on 30-06-2022. The existing 50MVA line reactor along with NGR in this line at Maithon-A end may be decommissioned prior to commissioning of above new 63MVA line reactor and NGR.

The implementation schedule of the scheme would be about 18 months. However, best efforts would be made to commission the reactor at the earliest.

(b) Augmentation of transformation capacity at Subhasgram (POWERGRID) S/s and other intra-state substations of WBSETCL

Presently, there are 4x315MVA + 1x500MVA ICTs at Subhasgram S/s. 2x315MVA + 1x500MVA is under ISTS and 2x315MVA has been installed by CESC. ERLDC had shared the ICTs loading details at Subhasgram S/s. Major highlights of the details shared by ERLDC is given below:

- In the present summer season (Apr-June 2022), N-1 reliability rating has been violated in 400/220kV Subhasgram (POWERGRID) ICTs on many occasions.
- The highest loading of about 1540MW was observed on 28th April 2022 both by CESC and WBSEDCL.
 - CESC maximum drawl was 803.17 MW on 28-04-2022 3:42 PM
 - WBSEDCL maximum drawl was 804.76 MW on 28-04-2022 11:25 PM
- The N-1 of CESC ICTs have been violated for about 74% of the time to meet its load.
- The N-1 of ISTS ICTs have been violated for about 11% of the time to meet WBSEDCL load.

In view of loading on existing ICTs not meeting the reliability criteria, there is an urgent requirement for installation of 6th 400/220kV, 500MVA ICT at Subhasgram (POWERGRID) S/s. ERLDC also emphasised regarding the urgent need for augmentation of transformation capacity at Subhasgram S/s. It was mentioned that major power demand of capital city of Kolkata is met from Subhasgram S/s, and any major overloading could result into cascaded tripping of ICTs, leading to major blackout in the area.

WBSETCL mentioned that since major over drawl at Subhasgram is by CESC, the 6th ICT may be installed at cost of CESC. CESC mentioned that as both CESC (74% of the time) and WBSEDCL/WBSETCL (11% of the time) drawl are not N-1 compliant, the cost of ICT in ISTS may be shared by both utilities.

All the stakeholders including CESC and WBSETCL agreed for installation of new ICT (6th) on technical grounds in the 9th CMETS-ER held on 29-07-2022. The matter was referred to ERPC meeting for resolution on the cost sharing mechanism between CESC and WBSETCL. In the 46th TCC & ERPC meeting held on 5th & 6th Aug 2022, CESC has agreed for installation of new 400/220kV, 500MVA ICT (6th) at Subhasgram (POWERGRID) S/s along with associated ICT bays at their own cost in similar manner as

that of the existing 400/220kV ICTs of CESC at Subhasgram (POWERGRID) S/s. The same was also agreed in the 10th meeting of CMETS-ER held on 30-08-2022.

(c) Modification in Eastern Region Expansion Scheme-XXXI (ERES-XXXI)

Installation of new 420kV, 1x63MVA_r line reactor at Maithon-A end of Maithon-A – Kahalgaon-B ckt-1 400kV line along with new 700ohm NGR (with NGR bypass arrangement for operation of line reactor as a bus reactor) was agreed in the 8th CMETS-ER held on 30-06-2022. After further studies and considering past operational experiences, size of the NGR has been reviewed and it has been observed that NGR of lower rating such as 500ohms would also be technically suitable along with the planned 63MVA_r line reactor. Accordingly, the modification in the rating of NGR was agreed in the 11th CMETS-ER held on 28-09-2022.

(d) Eastern Region Expansion Scheme-XXXII (ERES-XXXII)

420kV, 50MVA_r (3x16.67MVA_r) bus reactor-I (make-CGL) at Durgapur 400/220kV S/s was commissioned in 1991 and after serving for more than 30 years, it has been observed that the reactor is continuously giving problem like leakages, high moisture content and high temperature gradient etc. For further assessment of the health, matter was referred by POWERGRID to CPRI, Bangalore for Residual Life Assessment. After reviewing all parameters, CPRI has opined for replacement of the subject bus reactor. POWERGRID has informed that, the reactor has already completed designed electrical life and started to deteriorate, which requires replacement as individual component change would not resolve the issue. Further, spare/supports are very difficult for such ageing reactor from OEM.

Presently, there is a split bus arrangement at Durgapur S/s wherein section-A has 125MVA_r + 50MVA_r (3x16.67MVA_r) and section B has 2x125MVA_r bus reactors. The 50MVA_r bus reactor in section-A (installed in parallel with other 125MVA_r bus reactor) has been planned to be decommissioned and a new 125MVA_r bus reactor is planned to be installed in its place. As per the study, with switching of 125MVA_r bus reactor at Durgapur section-A, the bus voltage changes by about 3-4kV.

With installation of new 125MVA_r bus reactor in Durgapur section-A, both sections of Durgapur 400kV bus would have 2x125MVA_r bus reactors each. The proposal has been agreed in the 13th CMETS-ER held on 29-11-2022.

The implementation schedule of the scheme would be about 18 months from date of allocation.

7.4.3 Jharkhand

(a) Eastern Region Expansion Scheme-XXXI (ERES-XXXI)

Under ERSS-IX scheme, addition of 2x125MVA_r bus reactors in parallel with the existing 2x50MVA_r bus reactor was approved at Jamshedpur S/s. In case of space constraint for parallel operation of reactors, the existing 50MVA_r reactor may be replaced with the

125MVAR reactor and the released 50MVAR bus reactor would be utilised as a regional spare. Accordingly, Bus Reactor bank-1 comprising of 125MVAR + 50MVAR bus reactors and Bus reactor-2 comprising of 125MVAR only was commissioned. The released 50MVAR bus reactor, presently kept as regional spare has been proposed for replacement.

As per the NLDC operational feedback, the voltage at Jamshedpur 400kV bus has crossed the IEGC band during winters for almost 35-40% of the time. Therefore, bus reactor is required at Jamshedpur S/s.

In the 8th CMETS-ER, POWERGRID proposed that the 50MVAR bus reactor (3x16.67MVAR single phase reactors) in parallel with 125MVAR bus reactor at Jamshedpur S/s may also be considered for decommissioning considering its age. Further upon studies, voltage change of about 2-3kV was observed with switching of 125MVAR bus reactor. Accordingly, in view of decommissioning of two 50MVAR reactors and over voltages observed at Jamshedpur S/s, installation of a new 125MVAR bus reactor along with associated bay at Jamshedpur S/s under ISTS was agreed in the 8th CMETS-ER.

The implementation schedule of the scheme would be about 18 months. However, best efforts would be made to commission the reactor at the earliest.

(b) Establishment of 400/220/132kV substations in DVC area

The peak load of DVC is expected to increase to about 5700MW by 2026-27 time-frame. Further, 4x210MW generation at Mejia and 1x210MW generation at Waria, which are connected at 220kV level are expected to be decommissioned in phased manner in next 4-5 years. To compensate for the decommissioning of these generations and to feed the increasing load, DVC has planned for augmentation of 2x660MW generation capacity at Raghunathpur TPS. Since, old generation units of DVC were connected at 220kV and 132kV level, however, the new units at Bokaro, DSTPS, Mejia and Raghunathpur having unit sizes of 500MW and more capacity are connected at 400kV level.

Therefore, in the 6th CMETS-ER meeting held on 29-04-2022, it was agreed that DVC may establish 2 nos. of new 400kV substations viz. Gola-B and Ramkanali-B for evacuation of power from new generation projects (connected at 400kV) to the load centres with the following scope of works (schematic at **Figure 7-1**):

- (a) Establishment of Gola-B 400/220/132kV S/s:
 - (i) 400/220kV, 2x500MVA + 220/132kV, 2x200MVA
 - (ii) LILO of Raghunathpur TPS – Ranchi 400kV D/c line at Gola-B
 - (iii) LILO of Ramgarh-2B (newly proposed) – Ranchi 220kV S/c line (presently Ramgarh – Ranchi line) at Gola-B
 - (iv) LILO of Ramkanali-B (newly proposed) – Ramgarh-2B 220kV S/c line (presently MTPS – Ramgarh line) at Gola-B
 - (v) LILO of Ranchi – Ramkanali-B (newly proposed) 220kV S/c line (presently Ranchi – MTPS line) at Gola-B
 - (vi) LILO of CTPS – Gola 132kV D/c line at Gola-B

- (vii) 420kV, 2x125MVA bus reactor
- (viii) Adequate space for future expansion at 400kV, 220kV and 132kV levels including space for installation of new ICTs, bus/line reactors, and lines.
- (b) Establishment of Ramkanali-B 400/220/132kV S/s:
 - (i) 400/220kV, 2x315MVA (shifted from DSTPS) + 220/132kV, 3x200MVA (3rd 220/132kV ICT may be installed progressively with load growth)
 - (ii) LILO of Durgapur STPS – Raghunathpur TPS 400kV D/c line at Ramkanali-B
 - (iii) LILO of MTPS – Gola-B (newly proposed) 220kV S/c line (presently MTPS – Ranchi line) at Ramkanali-B
 - (iv) LILO of MTPS – Gola-B (newly proposed) 220kV S/c line (presently MTPS – Ramgarh line) at Ramkanali-B
 - (v) LILO of Ramkanali – CTPS 132kV D/c line at Ramkanali-B
 - (vi) 420kV, 2x125MVA bus reactor
 - (vii) Adequate space for future expansion at 400kV, 220kV and 132kV levels including space for installation of new ICTs, bus/line reactors, and lines.

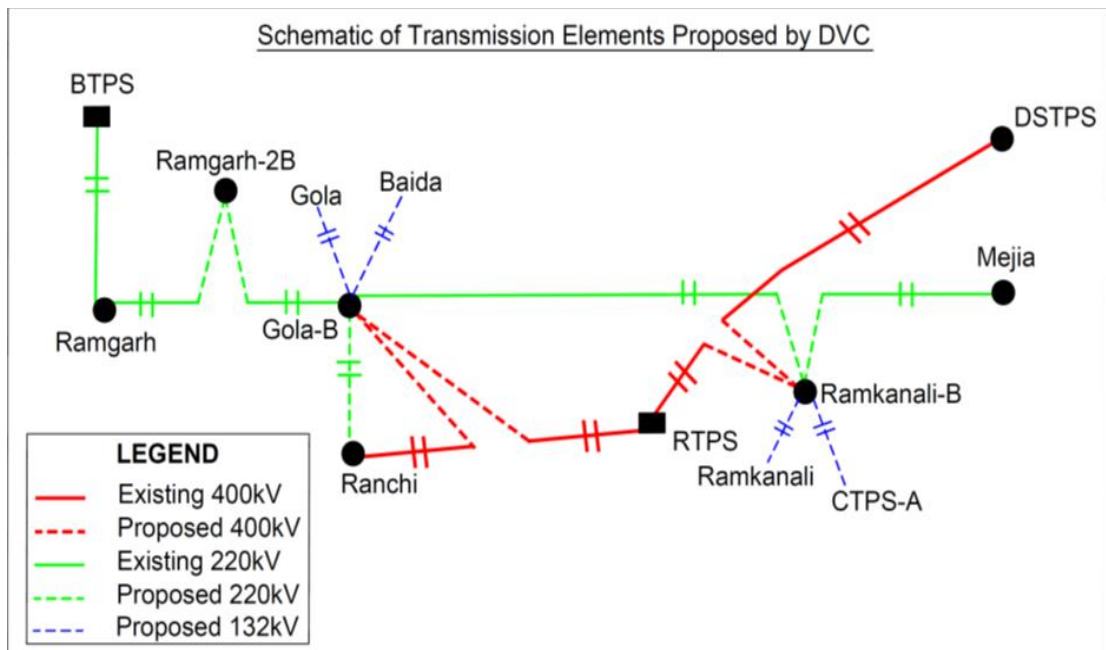

Figure 7-1: Proposed new 400kV substation in DVC area

In addition to above, augmentation of ICTs at following ISTS (DVC) S/s have also been discussed and agreed.

- (i) Bokaro-A TPS, 400/220kV: 2x315MVA ICTs to be replaced with 2x500MW by DVC. Replaced ICTs would be shifted to Mejia (2nd ICT) and RTPS / Ramkanali-B (3rd ICT)
- (ii) Durgapur TPS, 400/220kV: 2x315MVA ICTs to be replaced with 2x500MW by DVC. Replaced ICTs would be shifted to Ramkanali-B (1st and 2nd ICT) for its establishment

The implementation schedule of the scheme would be about 3-4 years.

7.4.4 Odisha

(a) Establishment of 400/220kV Joda Substation by OPTCL (Intra-state) & Eastern Region Expansion Scheme-XXIX (ERES-XXIX)

OPTCL has large numbers of Industries which is expected to come up in and around areas of Joda. Accordingly, OPTCL has planned to establish a new 400/220kV S/s at Joda New to feed the load of about 480MW. OPTCL requested CTU for ISTS connectivity from Rourkela 400/220kV and Keonjhar 400/220kV S/s alongwith LILO of Tikarpada – Joda 220kV line and Keonjhar – Joda 220kV line at Joda New.

Considering 400/220kV Rourkela substation as a strong source, the ISTS connectivity to new 400/220kV Joda substation was provided through Rourkela substation through LILO of existing ISTS Rourkela (POWERGRID) – Talcher (NTPC) 400kV D/c line at Joda New (to be implemented by OPTCL under intra-state scheme) with the following scope of works:

- (a) Establishment of 400/220kV, 3x500MVA Joda New S/s (3rd ICT to be installed progressively with demand growth)
- (b) LILO of existing ISTS Rourkela (POWERGRID) – Talcher (NTPC) 400kV D/c line at Joda New by OPTCL
- (c) 400kV, 2x125MVA bus reactor at Joda New
- (d) Adequate space for future expansion at 400kV, 220kV and 132kV levels including space for installation of new ICTs, bus/line reactors, and lines.
- (e) Reconductoring of Joda (OPTCL) – Jindal 220kV S/c line with Single HTLS of 1179A (at 120°C – ACCC Drake) along with necessary upgradation in bay equipment at both ends.

The above scheme was agreed in the 6th CMETS-ER meeting held on 29-04-2022.

With the integration of Joda New 400/220kV substation with the existing 220/132kV Joda (Barbil) substation, about 900MW power flows through the 400/220kV ICTs, most of the power flows from Jharsuguda – Rourkela – Joda 400kV corridor. Further, Rourkela substation also acts as a source of power to Jharkhand through Rourkela – Chaibasa and Rourkela – Ranchi 400kV D/c lines. Accordingly, ISTS transmission scheme under ERES-XXIX) with the scope of work viz. reconductoring of 400kV Jharsuguda – Rourkela 2xD/c lines with HTLS conductor in similar timeframe of establishment of Joda New 400/220kV substation was agreed in the 7th CMETS-ER meeting held on 31-05-2022 alongwith the upgradation of bay equipment at Rourkela end to match with the rating of HTLS line. However, no upgradation in line bays is envisaged at Jharsuguda/Sundargarh (POWERGRID) S/s as the existing line bays are rated for 3150A.

The implementation schedule of the scheme (ERES-XXIX) would be about 36 months.

(b) Eastern Region Expansion Scheme-XXXIV (ERES-XXXIV)

In the 1st CMETS-ER held on 25-11-2021, implementation of 765/400/220kV Paradeep substation under intra-state scheme was agreed to meet the upcoming industrial demand in the area. The feed was provided to Paradeep from Angul (POWERGRID) S/s through 765kV D/c line.

Now, Principal Secretary to Government, Department of Energy, Govt. of Odisha vide letter dated 27-12-2022 addressed to Secretary (Power), Ministry of Power, Govt. of Odisha has proposed for construction of Paradeep 765kV substation under ISTS.

New industrial demand in the range of 6-7GW is expected in Paradeep area starting from FY 2023-24. Paradeep is emerging as Green Hydrogen Hub and various industries have expressed investment intentions to set up Green Hydrogen and Green Ammonia plants in Paradeep due its locational advantage.

There is a requirement of ISTS corridor to supply RE power from outside Odisha, to meet the RPO of these industries. Thus, keeping in view critical nature of large industrial demand and quantum of power requirement it is essential that Paradeep substation is feed reliably from ISTS, and with high capacity lines.

The quantum of power requirement by some of the industries, viz. JSW Utkal Steel (340MW); IOCL (280MW) and Essar Steel (400MW) can be met through 220kV level. Accordingly, it is proposed to establish a 765/400/220kV substation at Paradeep under ISTS with two different sources viz. Angul and Medinipur in phased manner.

In the initial phase, Paradeep S/s along with Angul – Paradeep 765kV D/c line and Paradeep – Paradeep (OPTCL) 400kV D/c (Quad) line are planned to be established to meet the initial industrial demand of about 1400-1500MW. Subsequently, with growth in demand new 765/400kV or 400/220kV ICTs would be installed in progressive manner. In the subsequent phase, Angul – Paradeep 765kV 2nd D/c line and Paradeep – Medinipur 765kV D/c line to meet the industrial demand of about 5500-6000MW would be taken up progressively by 2027-28.

With establishment of Paradeep – Medinipur 765kV D/c link, Angul – Paradeep – Medinipur – Ranchi (New) – Dharamjaygarh – Sundargarh – Angul 765kV ring shall be established, which shall help in reliable transfer of RE power from outside ER to various states of ER viz. Odisha, Jharkhand, and West Bengal during high RE generation scenarios.

As Paradeep is in coastal area and within 60km from coastline, Paradeep (ISTS) S/s is planned to be implemented in GIS in line with the recommendation of Report of Task Force on Cyclone Resilient Robust Electricity Transmission and Distribution Infrastructure in coastal area published by CEA in May 2021 for construction of new substations upto 60km from the coastline.

The present scheme is for establishment of Paradeep 765/400/220kV, 2x1500MVA GIS substation along with Angul – Paradeep 765kV D/c line and Paradeep – Paradeep (OPTCL) 400kV D/c (Quad) line in initial phase, which has been approved in the 14th CMETS-ER held on 29th Dec 2022 and 48th TCC/ERPC meeting held on 17th and 20th Feb 2023. Balance portion would be taken up progressively with demand growth.

The Paradeep 765kV S/s approved under intra-state in the 1st CMETS-ER shall not be implemented by OPTCL in view of the instant plan of establishment of 765/400kV Paradeep GIS S/s in ISTS.

The implementation schedule of the scheme is about 24 months from date of SPV transfer.

7.4.5 Sikkim

(a) Eastern Region Expansion Scheme-XXX (ERES-XXX)

Presently 132/66kV Gangtok S/s is having 2x50MVA ICTs in service. Going by the loading profile in last winter (From Dec-21 to Feb-22) it is observed that due to huge load growth around Gangtok, both ICT's are loaded around 90% of the rated capacity. From the above, it is evident that N-1 reliability is not met at Gangtok S/s during peak load condition. Outage of any ICT during peak load condition might lead to cascaded tripping leading to large scale power outage. To mitigate the issue, it is essential to expeditiously install 3rd ICT at Gangtok S/s. In order to augment the transformation capacity at Gangtok S/s, the 3rd available 50MVA ICT (regional spare) may be paralleled with any of the 2x50MVA existing ICTs at present. After the supply of a new 100MVA ICT, the same may be installed in place of non-paralleled 50MVA ICT, thus the 50MVA ICT shall be released again as regional spare. This shall result in creation of 132/66kV, 2x100MVA transformation capacity at Gangtok S/s (2x50MVA in parallel + 100MVA).

Due to space constraints at Gangtok 132/66kV substation, POWERGRID has requested that a joint survey needs to be carried out for finalization of detailed scope for installation of ICTs in parallel including feasibility of transportation of new 100MVA ICT to Gangtok. The committee visited Gangtok substation and has recommended that the installation of new 132/66kV, 1x100MVA ICT is not feasible at Gangtok (POWERGRID) S/s, and also there are technical difficulties in paralleling of 50MVA ICTs. In view of above, the following scope of works was agreed under ERES-XXX for augmentation of transformation capacity at Gangtok S/s was agreed in the 10th CMETS-ER held on 30-08-2022:

- Installation of existing spare 132/66kV, 1x50MVA ICT (already stationed at Gangtok) as 3rd ICT at Gangtok (POWERGRID) S/s along with conversion of existing 132kV TBC bay as 132kV ICT bay for 3rd ICT and construction of new 66kV ICT bay in Hybrid/Outdoor GIS with suitable modification in the gantry structure of 66kV side.
- Construction of new 132kV TBC bay in Hybrid/Outdoor GIS.

The implementation schedule of the scheme would be about 24 months from the date of allocation.

(b) Eastern Region Expansion Scheme-XXXIII (ERES-XXXIII)

Presently, Gangtok 132/66kV S/s is fed from only one 132kV D/c line viz. Rangpo – Gangtok 132kV D/c line which is not N-1 compliant. Therefore, in the 9th CMETS-ER Reconductoring of Rangpo – Gangtok 132kV D/c line with HTLS conductor of 800A (at nominal voltage level) with upgradation of CTs at Gangtok end in both circuits of Rangpo – Gangtok 132kV D/c line from 600A to rating commensurate with rating of 800A HTLS conductor has been agreed under ERES-XXXIII in the 9th CMETS-ER held on 29-07-2022.

The implementation schedule of the scheme would be about 24 months from the date of allocation

7.5 Measures Taken for Mitigation of the Issues of Previous Rolling Plans

Various augmentation works have been discussed with the STUs in the CMETS-ER meetings and the steps taken to mitigate the constraints in ER for 2027-28 timeframe has been described below:

7.5.1 Measures for Controlling Overloading of Transmission Lines

As per the transmission line overloading report mentioned in the interim Rolling Plan published for 2027-28 timeframe, 4 nos. of transmission lines viz. Ranchi - Sipat 400kV D/c, Rourkela – Chaibasa 400kV D/c, Farakka – Sagardighi D/c and Kahalgaon – Farakka 400kV D/c lines were violating N-1 contingency criteria. The following reconductoring works were discussed and agreed in the CMETS-ER meeting:

- (i) Reconductoring of Jharsuguda (POWERGRID) – Rourkela (POWERGRID) 400kV 2xD/c Twin Moose line with Twin HTLS conductor (with ampacity Single HTLS as 1228A at nominal voltage) alongwith necessary bay upgradation works at Rourkela end.

These reconductoring works would relieve the overloading of Jharsuguda – Rourkela 400kV 2xD/c line. Additional studies needs to be carried out to overcome the loading in the remaining 400kV lines.

7.5.2 Measures for Controlling Overloading of ICTs

As per the ICT overloading report mentioned in the interim Rolling Plan published for 2027-28 timeframe, ICTs at 3 nos 765/400kV S/s viz. Gaya, Jharsuguda, Jeerat New and 7 nos. of ISTS S/s viz, Rajarhat, Subhasgram, Durgapur TPS, Bokaro-A TPS, Koderma TPS, Raghunathpur TPS were violating N-1 contingency criteria. Out of these, following ICT augmentation was discussed in the CMETS-ER meeting:

- (i) Bokaro-A TPS, 400/220kV: 2x315MVA ICTs to be replaced with 2x500MW by DVC. Replaced ICTs would be shifted to Mejia (2nd ICT) and RTPS / Ramkanali-B (3rd ICT)

- (ii) Durgapur TPS, 400/220kV: 2x315MVA ICTs to be replaced with 2x500MW by DVC. Replaced ICTs would be shifted to Ramkanali-B (1st and 2nd ICT) for its establishment
- (iii) Subhasgram 400/220kV: New 1x500MVA ICT to be installed by CESC as 6th ICT.

These augmentation works would relieve the overloading of Durgapur TPS, Bokaro-A TPS, Raghunathpur TPS and Subhasgram S/s.

7.5.3 Measures for Controlling Fault level of Substations

As per the fault level violation report mentioned in the interim Rolling Plan published for 2027-28 timeframe, fault level at 4 nos. of ISTS S/s viz, Barh, Farakka, Siliguri, and Ranchi S/s were crossing their designed limit. Out of these, following transmission scheme was discussed in the CMETS-ER meeting to control the fault level:

- (i) Patna 400kV: Bypassing of Patna – Barh 400kV D/c (Quad) line (ckt-3 & 4) (68.9km) and Patna – Naubatpur 400kV D/c (Quad) line (25.45km) at Patna S/s so as to form Barh – Naubatpur 400kV D/c (Quad) line

This would relieve the fault level of Patna S/s as well as Barh generation switchyard.

Detailed study for controlling the fault level of Ranchi S/s is under progress.

7.6 System Study Results and Analysis

Based on the load-generation scenarios as elaborated in **section 7.3**, various system studies have been carried out in PSSE. Planned/ Under implementation Transmission system that are expected to be commissioned in 2027-28 timeframe are considered for conducting these studies. Results of these studies were analysed and the same are deliberated below-

7.6.1 Power Flow Analysis

d) Transmission Lines

In the base case file prepared for 2027-28 timeframe, 3 nos. of 400 kV lines are having loading more than 70% of the thermal limit of the line. Scenarios where loading is more than 70% of rating and maximum loading obtained on these transmission lines in the simulation studies are tabulated below at **Table 7-7**

Table 7-7: Transmission Lines Loading in the Base Cases

(All Fig in MW)

Sl. No.	Name of the Line	Scenario No.	Owner	Maximum Loading (MW)	Rating (MW)	Remark
1.	Rourkela – Chaibasa 400kV D/c line	4	ISTS	746	850 (Twin Moose)	Due to high generation in Chattisgarh, and low generation in West Bengal, this problem has arised. Additional corridor from Jharsuguda to Jharkhand
2.	Sipat – Ranchi 400kV D/c line	4	ISTS	838	850 (Twin Moose)	

Sl. No.	Name of the Line	Scenario No.	Owner	Maximum Loading (MW)	Rating (MW)	Remark
						may be planned to control this power flow.
3.	Purnea- Siliguri 400kV D/c line	5	ISTS	775	1093 (Twin Moose)	High hydro generation in Sikkim and Bhutan and low despatch at Alipurduar HVDC (ER importing scenario)

e) Transformers

In the base case file prepared for 2027-28 timeframe, transformers at 3 nos. of 765/400 kV substations and 12 nos. of 400/220kV substations are having loading more than 80% of the ICT rating. Scenarios where loading is more than 80% of rating and maximum loading hit by these transformers in the simulation studies are tabulated below at **Table 7-8**.

Table 7-8: Transformers Loading in the Base Cases

(Max Loading in MW)

Sl. No.	Name of the Element	Scenario No.	Owner	Maximum Loading	Rating (MVA)	Remark
1.	400/220kV, 2x315MVA ICTs at Duburi	2,3,4,5, 7,8	STU (OPTCL)	290	315	Industrial demand in Bhadrak and Duburi Area
2.	400/220kV, 3x315MVA ICTs at Mendhasal	8	STU (OPTCL)	255	315	Additional drawal in Bhubaneshwar area
3.	400/220kV, 2x315MVA ICTs at Lapanga	7	STU (OPTCL)	262	315	Industrial demand in Lapanga Area
4.	400/220kV, 2x315MVA ICTs at Kolaghat TPS	1,2,3,4 5	STU (WBSETCL)	339	315	WBSETCL has proposed to shift 210MW units from 400kV level to 220kV level to reduce the loading of ICTs.
5.	400/220kV, 3x315MVA ICTs at Chanditala	1,2,4,5	STU (WBSETCL)	327	315	WBSETCL may take action regarding upgradation / replacement of ICT as discussed in the CMETS
6.	400/220kV, 3x315MVA ICTs at Kharagpur	2	STU (WBSETCL)	273	315	
7.	400/220kV, 4x315MVA ICTs at Jeerat	2	STU (WBSETCL)	279	315	
8.	400/220kV, 2x500MVA ICTs at Durgapur TPS	2	ISTS (DVC)	418	500	Retirement of old 220kV units in the DVC System

Sl. No.	Name of the Element	Scenario No.	Owner	Maximum Loading	Rating (MVA)	Remark
9.	400/220kV, 2x315MVA ICTs at Mejia TPS	4	ISTS (DVC)	253	315	

f) Voltage Analysis

PU voltages of all 400kV and above buses were observed in all the nine scenarios. Maximum and minimum voltage of each bus were identified from the bus voltages in the nine number of scenarios. It has been observed that all buses at 132kV and above are having voltage between 0.95 pu and 1.05pu

7.6.2 Contingency Analysis

Contingency analysis has been performed on all the 765kV & 400kV transmission lines, and 765/400kV & 400/220kV transformers to ascertain the loading levels under outage of any other 765kV or 400kV transmission element. Results of the analysis are discussed below:

c) Transmission Lines

ISTS lines loaded beyond 100% of thermal rating under N-1 contingency are summarized below at **Table 7-9**.

Table 7-9: ISTS Transmission lines not meeting N-1 Criteria in ER

(All Fig in MW)

Sl. No.	Name of the Line	Contingency	Scenario No.	Owner	Base case Loading	Loading under N-1	Rating	% Loading
1.	Ranchi – Sipat 400kV line-1	Ranchi – Sipat 400kV line-2	4	ISTS	838	1039	850 (Twin Moose)	116%
2.	Purulia New – Purulia PS 400kV Line-1	Purulia New – Purulia PS 400kV Line-2	1,4,7	ISTS	582	1041	850 (Twin Moose)	121%

From the above, it can be seen that the above-mentioned lines are violating N-1 contingency limit. This is due to high injection of renewable generations leading of less thermal generations in ER in the Jharkhand, DVC and West Bengal area. These overloadings may be minimized with switching of some of the generations in these areas.

Further, no STU lines is observed to be loaded beyond 100% of thermal rating under N-1 contingency.

d) Transformers

ISTS ICTs loaded beyond 100% of MVA rating under N-1 contingency are summarized below at **Table 7-10**

Table 7-10: ISTS ICTs not meeting N-1 Criteria in ER

(All Fig in MW)

Sl. No.	Name of the Element	Scenario No.	Owner	Base Case Flow	Loading of ICT under N-1	% Loading	Rating (MVA)	Remark
1.	765/400kV, 4X1500 MVA ICTs at Jharsuguda-B	4	ISTS	1040	1631	109%	1500	High RE injection from NR/WR. After removal of 400kV LILOs at Angul, the major demand of Odisha is met from Jharsuguda S/s only.
2.	400/220kV, 3x500MVA ICTs at Durgapur-B	4,6	ISTS	254	321	102%	315	Under Boundary Condition. May be reviewed under next rolling plan
3.	400/220kV, 2x500MVA ICTs at Durgapur TPS	2,4,5,6	ISTS (DVC)	428	613	123%	500	Retirement of old 220kV units in the DVC System. Augmentation of ICTs by DVC.
4.	400/220kV, 2x315MVA ICTs at Mejia-B TPS	4,6,7	ISTS (DVC)	263	358	114%	315	
5.	400/220kV, 2x315MVA ICTs at Bokaro-A TPS	7	ISTS (DVC)	340	522	104%	500	Proper utilization of Dhanbad 400kV (ISTS) S/s may reduce the loading of Bokaro ICTs. DVC may plan 220kV outlets from Dhanbad ISTS to feed the loads at Bokaro.

Requirement of additional transformation augmentation wherever necessary would be planned subsequently in coordination in the CMETS meeting and the same would be included in the next Rolling Plan.

STU ICTs loaded beyond 100% of MVA rating under N-1 contingency are summarized below at **Table 7-11**

Table 7-11: STU ICTs not meeting N-1 Criteria in ER

(All Fig in MW)

Sl. No.	Name of the Element	Scenario No.	Owner	Base Case Flow	Loading of ICT under N-1	% Loading	Rating (MVA)
1.	400/220kV, 2x315MVA ICTs at Duburi	All	OPTCL	303	421	133%	315
2.	400/220kV, 3x315MVA ICTs at Mendhasal	8	OPTCL	272	336	107%	315
3.	400/220kV, 2x315MVA ICTs at Lapanga	7,8	OPTCL	262	371	118%	315

Sl. No.	Name of the Element	Scenario No.	Owner	Base Case Flow	Loading of ICT under N-1	% Loading	Rating (MVA)
4.	400/220kV, 4x315MVA ICTs at Jeerat	2	WBSETCL	280	328	104%	315
5.	400/220kV, 2x315MVA ICTs at Kolaghat TPS	All except 6& 9	WBSETCL	341	506	161%	315
6.	400/220kV, 3x315MVA ICTs at Chanditala	1,2,4,5	WBSETCL	332	407	129%	315
7.	400/220kV, 3x315MVA ICTs at Kharagpur	1,2,4,5	WBSETCL	274	377	120%	315
8.	400/132kV, 2x315MVA ICTs at New Laxmikantpur	2	WBSETCL	235	343	109%	315

From above, it is observed that 3 nos. of S/s of OPTCL and 5 nos. of S/s of WBSETCL/WBSEDCL are not complying N-1 criteria in 2027-28 timeframe. Some of them are violating the limits in present timeframe also and are continuously flagged by Grid-India in their Operational Feedback. Most of these ICTs of WBSETCL & OPTCL are hitting more than 120% loading under N-1 Contingency. WBSETCL / OPTCL may take actions in a progressive manner for upgradation / replacement of ICT as discussed in the CMETS-ER meeting.

7.6.3 Short Circuit Analysis

Short circuit level was calculated for all 765 and 400 kV buses of Eastern Region and buses having fault level more than the design rating under any scenario were identified. From analysis, it is emerged that 3 nos. of 400kV ISTS S/s and 1 nos STU S/s in ER have crossed their designed fault level rating.

Details of the ISTS buses exceeding the designed fault level under any scenario are tabulated below at **Table 7-12**

Table 7-12: ISTS Buses Exceeding Designed Fault Level in ER

(All Fig in kA)

Sl. No.	Substation Name	Owner	Scenario No.	Highest Fault level	Designed Rating
1.	400kV Farakka	NTPC	2,3,7,8,9	41	40
2.	400kV Siliguri	POWERGRID	3,8,9	41	40
3.	400kV Ranchi	POWERGRID	All except 4	46	40

From the above, it can be seen that 3 nos. of buses i.e. 400kV Farakka, 400kV Siliguri & 400kV Ranchi violates the design fault level. The fault level control measures for Farakka have been implemented. Detailed studies are being carried out for the balance 2 no. S/s and the same

would be discussed in the upcoming CMETS-ER meeting and the corrective measures shall be included in the next Rolling Plan.

Details of the ISTS buses exceeding the designed fault level under any scenario are tabulated below at **Table 7-13**.

Table 7-13: STU Buses Exceeding Designed Fault Level in ER

(All Fig in kA)

Sl. No.	Substation Name	Owner	Scenario No.	Highest Fault level	Designed Rating
1.	400kV Patratu	JUSNL	2,8,9	41	40

JUSNL may take necessary actions such as bus splitting, bypassing of lines, fault limiting reactors etc to resolve the issue of high fault level at their buses.

Page intentionally left blank

Chapter 8: North Eastern Region

North Eastern Region is the eastern-most region of India. It comprises seven states, the contiguous Seven Sister States. The region shares an international border with several neighbouring countries, China in the north, Myanmar in the east, Bangladesh in the south-west and Bhutan in the north-west. The NER has immense natural resources, accounting for 34% of the country's water resources and almost 40% of India's hydropower potential. The states in NER are well connected through EHV transmission links at 400kV level. The NER grid is further strongly connected to other parts of the National Grid through 400kV HVAC lines as well as ± 800 kV, 6000MW Multi terminal Biswanath Chariali – Alipurduar – Agra HVDC link. North Eastern Region is also connected to Bhutan for import of power from hydro generations. Further, North Eastern Region is also connected to Myanmar and Bangladesh for export of power.

8.1 Power Supply Scenario as on Feb'23

As on Feb'23, total Installed Capacity (IC) of North Eastern Region was about 4774MW and the peak demand met was about 3603MW. The state-wise breakup of installed capacity and peak demand is summarised at **Table 8-1** below.

Table 8-1: Installed Capacity and Peak Demand of NER as on Feb '23

(All Fig in MW)

State	Generation							Grand Total	Peak Demand
	Fossil			Non Fossil					
	Thermal	Gas	Total	Nuclear	Hydro	RES (MNRE)	Total		
Assam	403	742	1144	-	522	184	706	1851	2376
Arunachal Pradesh	37	47	84	-	545	145	689	773	166
Meghalaya	-	110	110	-	417	50	468	578	333
Tripura	-	487	487	-	68	34	102	589	333
Manipur	52	82	133	-	87	18	105	238	248
Nagaland	32	74	106	-	66	35	101	207	167
Mizoram	10	60	71	-	98	53	151	222	159
Central unallocated	113	64	176	-	140	-	140	316	-
NER	646	1665	2311	-	1944	519	2463	4774	3603

Source: CEA monthly report

8.2 Envisaged Power Supply Scenario by 2027-28

As per the 20th EPS, North Eastern Region demand for 2027-28 timeframe is expected to increase to about 5159MW. As per the inputs received from various stakeholders, total installed capacity of North Eastern Region for 2027-28 is expected to be about 7534MW. The state wise bifurcation of installed capacity and peak demand is summarized below at **Table 8-2**.

Table 8-2: North Eastern Region Installed Capacity and peak demand (2027-28)

(All Fig in MW)

State	Generation									Peak Demand
	Fossil			Non Fossil				ESS	Grand Total	
	Thermal	Gas	Total	Nuclear	Hydro	RES	Total			
Arunachal Pradesh	-	-	-	-	24	100	124	-	124	234
Assam	-	347	347	-	220	-	220	-	567	3240
Manipur	-	-	-	-	-	-	-	-	-	363
Meghalaya	-	-	-	-	490	-	490	-	490	510
Mizoram	-	-	-	-	28	-	28	-	28	249
Nagaland	-	-	-	-	24	-	24	-	24	204
Tripura	-	149	149	-	-	-	-	-	149	567
Central	750	1353	2103	-	3630	-	3630	-	5733	-
NER	750	1849	2599	-	4416	100	4516	-	7114	5159

There is a massive growth in peak demand of North Eastern Region from present time-frame (2022-23) to 2027-28 with a CAGR of 7.4%. The state wise peak demand growth is given at **Table 8-3**.

Table 8-3: Increase in Peak Demand of Various States of NER

(All Fig in MW)

State	2022-23	2027-28	Increase in demand	CAGR
Assam	2376	3240	864	6.4%
Arunachal Pradesh	166	234	68	7.1%
Meghalaya	404	510	106	4.8%
Tripura	333	567	234	11.2%
Manipur	248	363	115	7.9%
Nagaland	167	204	37	4.1%
Mizoram	159	249	90	9.4%
NER	3603	5159	1556	7.4%

From the above data it is observed that the CAGR growth of peak demand is maximum for Tripura (11.2%) and minimum for Nagaland (4.1%). The CAGR of demand of NER is about 7.4% which is more than the National Average of 6.9%. In addition to above, 250MW demand of Myanmar & 160MW demand of Bangladesh is also considered as a part of North Eastern Region for study purpose.

8.3 Load Generation Balance for 2027-28 timeframe

In the chapter 3, All India Load Generation Balance (LGB) for identified nine scenarios was prepared as per the methodology finalized in consultation with CTU, CEA and Grid India. This section elaborates the North Eastern Region Load Generation Balance (LGB) for 2027-28 time-frame. For North Eastern Region also, three points on the daily load curve i.e. Solar max (afternoon), Peak load (evening) and Off-peak load (night) for three seasons viz. Monsoon (August), Summer (June) and Winter (February) have been considered.

Load generation balance has been prepared considering the generation despatch factors as mentioned at **Table 8-4** for the 9 scenarios. Further, thermal generators have been despatched as per the merit order.

Table 8-4: North Eastern Region Generation Dispatch and Demand Factors

Scenario No & Name	Generation Dispatch Factors			Demand Factors
	Hydro	Solar	Gas	
1-Aug Solar Max	70%	80%	0%	68%
2-Aug Peak Load	90%	0%	50%	92%
3-Aug Night Off Peak	70%	0%	50%	62%
4-Jun Solar Max	70%	85%	0%	63%
5-Jun Peak Load	90%	0%	50%	72%
6-Jun Night Off Peak	70%	0%	50%	48%
7-Feb Solar Max	30%	90%	0%	54%
8-Feb Peak Load	60%	0%	50%	75%
9-Feb Night Off Peak	30%	0%	30%	34%

The despatch from thermal generations have been done considering merit order despatch. Based on the LGB, import / export of NER and the inter-regional flows through various corridors is summarised in **Table 8-5**. Further, both maximum and minimum is also highlighted in table below.

Table 8-5: Import / Export of North Eastern Region

(All Fig in MW)

State / UTs	Import / Export of North Eastern Region								
Scenario No	Aug'27 Time Frame			Jun'27 Time Frame			Feb'28 Time Frame		
	1 (Solar Max)	2 (Peak Load)	3 (Off Peak)	4 (Solar Max)	5 (Peak Load)	6 (Off Peak)	7 (Solar Max)	8 (Peak Load)	9 (Off Peak)
NER-ER	-3	121	706	414	1166	1263	-1103	-351	-37
NER-NR	-500	0	0	-500	0	0	-500	0	0
NER-B'Desh	160	160	160	160	160	160	160	160	160
NER-Bhutan	-94	-122	-85	-76	-102	-75	-63	-93	-46
NER-M'mar	250	250	250	250	250	250	250	250	250
North Eastern Region	-187	409	1031	248	1474	1598	-1256	-34	327

Out of these nine scenarios, Scenario-6 and Scenario-7 corresponds to two extreme cases with export/import requirement of North Eastern Region i.e. Maximum export (1600MW) and maximum import (1260MW) scenarios respectively. In all other scenarios, the import / export of North Eastern Region varies between these two extremes.

Considering the above LGB for nine scenarios, load flow cases were prepared for 2027-28 timeframe. Detailed system studies have been carried out on the finalized load flow cases. The study results are discussed in subsequent sections.

8.4 ISTS Network Expansion Schemes evolved from Mar'22 to Feb'23

Various transmission schemes have been discussed/finalized in the Consultative Meeting for Evolution of Transmission System of North Eastern Region (CMETS-NER) from March 2022 to Feb 2023. The details of the schemes are summarized below in **Table 8-6**:

Table 8-6: Approved Transmission Schemes in this Rolling Plan

Sl. No.	Name of the Transmission Scheme	Expected Timeframe	Tentative Cost (in ₹Cr.)
Mizoram			
1.	North-Eastern Region Expansion Scheme-XVIII (NERES-XVIII)	Apr '25	11.49
Manipur			
1.	North-Eastern Region Expansion Scheme-XIX (NERES-XIX)	Apr '24	15.6
Meghalaya			
1.	North-Eastern Region Expansion Scheme-XX (NERES-XX)	Nov '24	77.04
2.	North-Eastern Region Expansion Scheme-XXI (NERES-XXI)	Dec '25	35
Assam			
1.	North-Eastern Region Expansion Scheme-XXI (NERES-XXI)	Dec '25	45

8.4.1 Mizoram

(a) North-Eastern Region Expansion Scheme-XVIII (NERES-XVIII)

Upon studies for 2026-27 timeframe, it was found that some of the lines in the eastern part of Meghalaya grid are getting overloaded under various scenarios. These lines are very old and the thermal limits are also low. Details of the same are given below:

i) Reconductoring of Melriat (POWERGRID) – Zuangtui (Mizoram) 132kV line

Presently, 132kV Melriat (POWERGRID) – Zuangtui (Mizoram) line carries about 70MW power. In future time frame of 2024-25, power demand of Mizoram is expected to grow to about 215MW from present level of about 160MW, and in such case the Melriat (POWERGRID) – Zuangtui 132kV line is found to be critically loaded in base case itself, about 88MW. Further, with N-1 of either Sihhmui – Zuangtui or Aizawl (POWERGRID) – Luangmual, the loading on Melriat (POWERGRID) – Zuangtui 132kV line increases to 112MW or 146MW respectively. N-1 of Melriat (POWERGRID) – Zuangtui results in overloading of Sihhmui – Zuangtui line. Accordingly, for reliable power supply to Mizoram from ISTS, reconductoring of Melriat (POWERGRID) – Zuangtui (Mizoram) 132kV S/c ISTS line and Sihhmui – Zuangtui 132kV S/c Intra-State line has been agreed in the 8th CMETS-NER held on 27-06-2022.

Reconductoring of Melriat (POWERGRID) – Zuangtui (Mizoram) 132kV ACSR Panther S/c line with Single HTLS rating of 900A along with upgradation of line bay equipment at Melriat (POWERGRID) and Zuangtui (Mizoram) ends commensurate with rating of HTLS, as required has been agreed in 8th CMETS-NER.

ii) Reconductoring of Aizawl (POWERGRID) – Luangmual (Mizoram) 132kV line

It has been observed that to meet the power supply requirement of central and southern part of Mizoram, with about 100MW of demand, there are only two 132kV lines viz. Aizawl (POWERGRID) – Luangmual and Zuangtui – Serchip. N-1 of any of these two lines, results in overloading of the other line. Moreover, N-1 of these lines, results in

Luangmual or Serchip getting feed through about 250km long 132kV corridor, which results into critical voltage drop along the corridor necessitating requirement of capacitor banks at intermediate substations in southern part of Mizoram. In case of N-1 of Aizawl (POWERGRID) – Luangmual line, complete voltage collapse occurs in southern Mizoram grid without capacitive support, as the major part of Mizoram gets dependent for power from a single source viz. Zuangtui.

In view of the above, reconductoring of both Aizawl (POWERGRID) – Luangmual (Mizoram) 132kV S/c ISTS line and Zuangtui (Mizoram) – Serchip (Mizoram) 132kV S/c Intra-State line along with installation of capacitor banks in southern Mizoram grid (under intra-state) has been agreed in the 8th CMETS-NER dated 27-06-2022. Reconductoring of Aizawl (POWERGRID) – Luangmual (Mizoram) 132kV ACSR Panther S/c line with Single HTLS rating of HTLS conductor of 900A along with upgradation of line bay equipment at Aizawl (POWERGRID) and Luangmual (Mizoram) ends commensurate with rating of HTLS, as required has been agreed in 8th CMETS-NER.

Thus, following scope of works was agreed:

- i. Reconductoring of Melriat (POWERGRID) – Zuangtui (Mizoram) 132kV ACSR Panther S/c line with Single HTLS conductor of 900A (at nominal voltage level).
- ii. One (1) new 132kV line bay at Melriat (POWERGRID) S/s (of rating commensurate with rating of HTLS viz. 900A) for termination of Melriat (POWERGRID) – Zuangtui (Mizoram) 132kV HTLS line.
- iii. Replacement of existing CT of 600/1A at Zuangtui (Mizoram) end in Melriat (POWERGRID) – Zuangtui (Mizoram) 132kV S/c line with rating commensurate with ampacity (900A) of HTLS conductor.
- iv. Reconductoring of Aizawl (POWERGRID) – Luangmual (Mizoram) 132kV ACSR Panther S/c line with Single HTLS rating of HTLS conductor of 800A (at nominal voltage level).
- v. Replacement of existing CT of 600/1A at Luangmual (Mizoram) end in Aizawl (POWERGRID) – Luangmual (Mizoram) 132kV S/c line with rating commensurate with ampacity (800A) of HTLS conductor

The implementation schedule of the scheme would be about Apr 2025.

8.4.2 Manipur

(a) North-Eastern Region Expansion Scheme-XIX (NERES-XIX)

Loktak (NHPC) – Imphal (POWERGRID) 132kV S/c line (36.6km) is very old (commissioned in June 1982). 132kV lines in this area are in difficult hilly terrain and prone to frequent outages, which affects reliability of power drawl requirement in the area. N-1-1 contingency near Loktak HEP (105MW) results in power evacuation constraints for Loktak HEP. Since Dimapur – Imphal and Loktak – Jiribam 132kV S/c lines are already

agreed for reconductoring with HTLS conductor hence Loktak – Imphal becomes limiting constraint for power evacuation from Loktak HEP. In first week of May 2022 simultaneous outage of Jiribam (MSPCL) – Rengpang and Loktak – Ningthoukhong occurred, which resulted in limitation in power evacuation from Loktak HEP to 70MW. Thus, Loktak – Rengpang – Jiribam (MSPCL) does not offer reliable path for power evacuation. Accordingly, for reliable power evacuation, and reliable & secure power supply in the area including state capital of Imphal, reconductoring of Loktak (NHPC) – Imphal (POWERGRID) 132kV S/c line with HTLS conductor of 800A along with bay upgradation (change of CT) and strengthening of associated structure in NHPC switchyard, if required, was agreed in 8th CMETS-NER held on 27-06-2022.

Thus, following scope of works was agreed:

- i. Reconductoring of Loktak (NHPC) – Imphal (POWERGRID) 132kV S/c line with HTLS conductor (with Ampacity of single HTLS as 800A at nominal voltage) along with strengthening of associated structure in NHPC switchyard, if necessary.
- ii. Replacement of existing CT of 600-400-200/1A at Loktak HEP end in Loktak – Imphal 132kV S/c line with rating commensurate with ampacity (800A) of HTLS conductor.

The implementation schedule of the scheme would be about 18 months from date of allocation.

8.4.3 Meghalaya

(a) North Eastern Region Expansion Scheme-XX (NERES-XX)

Upon studies for 2026-27 timeframe, it was found that some of the lines in the eastern part of Meghalaya grid are getting overloaded under various scenarios. These lines are very old and the thermal limits are also low. Details of the same are given below:

- i) **Reconductoring of Kopili (NEEPCO) – Khandong (NEEPCO) 132kV line-1, Khandong (NEEPCO) – Khliehriat (POWERGRID) 132kV line and Khliehriat (POWERGRID) – Badarpur (POWERGRID) 132kV line:**

In 2026-27-time frame, in the base case scenario, the power flow through Kopili (NEEPCO) – Khandong (NEEPCO) 132kV line-1, Khandong (NEEPCO) – Khliehriat (POWERGRID) 132kV D/c line and Khliehriat (POWERGRID) – Badarpur (POWERGRID) 132kV S/c line is about 70MW, 60MW and 51MW respectively. The thermal limit of Kopili (NEEPCO) – Khandong (NEEPCO) 132kV line-1, Khandong (NEEPCO) – Khliehriat (POWERGRID) 132kV D/c line and Khliehriat (POWERGRID) – Badarpur (POWERGRID) 132kV S/c line is about 40MW each. Accordingly, for reliable power supply to Meghalaya, reconductoring of Kopili (NEEPCO) – Khandong (NEEPCO) 132kV line-1, Khandong (NEEPCO) – Khliehriat (POWERGRID) 132kV line-1 and Khandong (NEEPCO) – Khliehriat (POWERGRID) 132kV line-2 with ampacity (800A)

of HTLS conductor for each line and Khliehriat (POWERGRID) – Badarpur (POWERGRID) 132kV S/c line with ampacity (900A) along with replacement of existing CTs at both ends with rating commensurate with ampacity (900A) of HTLS conductor of HTLS conductor has been agreed in the 11th CMETS-NER held on 29-09-2022.

ii) Reconductoring of Khliehriat (POWERGRID) – Khliehriat (MePTCL) 132kV D/c line:

Similarly, on N-1 contingency of Khlieriat (MePTCL) – Khlieriat (PG) 132kV ckt-2, the loading on Khliehriat (POWERGRID) – Khliehriat (MePTCL) 132kV line-1 increases to about 70MW and with N-1 of Khlieriat (MePTCL) – Khlieriat (PG) 132kV ckt-1, the loading on Khliehriat (POWERGRID) – Khliehriat (MePTCL) 132kV line-2 increases to 72MW, which is found to be critically loaded as the thermal limit of Khandong (NEEPCO) – Khliehriat (POWERGRID) 132kV ckt-1 (ISTS) and Khandong (NEEPCO) – Khliehriat (POWERGRID) 132kV ckt-2 (Intra-state) line is about 40MW and 60MW respectively. In view of the above both Khandong (NEEPCO) – Khliehriat (POWERGRID) 132kV ckt-1 (ISTS) and Khandong (NEEPCO) – Khliehriat (POWERGRID) 132kV ckt-2 (Intra-state) line along with replacement of existing CTs at both ends with rating commensurate with ampacity (800A) of HTLS conductor has been agreed in the 11th CMETS-NER held on 29-09-2022.

Thus, following scope of works was agreed:

- Reconductoring of existing Single ACSR Panther Kopili (NEEPCO) – Khandong (NEEPCO) 132kV S/c line-1 (10.9km) of POWERGRID with Single HTLS conductor of ampacity of 800A (at nominal voltage level & considering 40°C ambient temp.) along with replacement of existing wave trap at Kopili end and CT at Khandong end with rating commensurate with ampacity (800A) of HTLS conductor.
- Reconductoring of existing Single ACSR Panther Khandong (NEEPCO) – Khliehriat (POWERGRID) 132kV S/c line-1 (42.48km) of POWERGRID with Single HTLS conductor of ampacity of 800A (at nominal voltage level & considering 40°C ambient temp.) along with replacement of existing CTs at both ends with rating commensurate with ampacity (800A) of HTLS conductor.
- Reconductoring of existing Single AAAC Panther Khandong (NEEPCO) – Khliehriat (POWERGRID) 132kV S/c line-2 (40.93km) of POWERGRID with Single HTLS conductor of ampacity of 800A (at nominal voltage level & considering 40°C ambient temp.) along with replacement of existing CTs at both ends & wave trap at Khandong end with rating commensurate with ampacity (800A) of HTLS conductor, and strengthening of requisite tower members (approx. 0.348 MT).
- Reconductoring of existing Single ACSR Panther Khliehriat (POWERGRID) – Khliehriat (MePTCL) 132kV S/c POWERGRID line-1 (7.8km) of POWERGRID with Single HTLS conductor of ampacity of 800A (at nominal voltage level & considering

40°C ambient temp.) along with replacement of existing CTs at both ends with rating commensurate with ampacity (800A) of HTLS conductor, and strengthening of requisite tower members (approx. 0.121 MT).

- Reconductoring of existing Single AAAC Panther Khliehriat (POWERGRID) – Badarpur (POWERGRID) 132kV S/c line (76.64km) with Single HTLS conductor of ampacity of 900A (at nominal voltage level & considering 40°C ambient temp.) along with replacement of existing CTs at both ends with rating commensurate with ampacity (900A) of HTLS conductor.
- Replacement of existing bus coupler bay CT at Khandong HEP (NEEPCO) switchyard from 600A to 800A

The implementation schedule of the scheme would be about 24 months from date of allocation.

(b) North Eastern Region Expansion Scheme-XXI (NERES-XXI)

With the completion of 25 years of commercial operation by Feb '24, it was proposed for upgradation of Single Main and Transfer Bus to Double Bus arrangement with GIS at 132kV Khliehriat.

The proposal for upgradation of the switching scheme is mainly due to reliability and issues faced in O&M of these substations as for maintenance/replacement of equipment, shutdown of the entire substation is required. As this substation are feeding important load to the nearby areas of Khliehriat in Meghalaya, taking long shutdown would affect the power supply in these areas. Also, there are space constraints in the upgradation of the bus bar scheme. Therefore, upgradation of the bus scheme in GIS may be taken up as this would help in parallel working in the substation without interrupting the power supply for longer time in these areas. Upgradation of the bus schemes in GIS would allow additional space for future interconnections.

Thus, following scope of works was agreed in the 16th CMETS-NER held on 24-02-2023:

- (a) Upgradation of Single Main and Transfer Bus to Double Bus arrangement with GIS at 132kV Khliehriat (POWERGRID) switching station

Implementation timeframe: 30 months from date of allocation.

8.4.4 Assam

(a) North Eastern Region Expansion Scheme-XXI (NERES-XXI)

With the completion of 25 years of commercial operation by Feb '24, it was proposed for upgradation of Single Main and Transfer Bus to Double Bus arrangement with GIS at 132kV Badarpur.

The proposal for upgradation of the switching scheme is mainly due to reliability and issues faced in O&M of these substations as for maintenance/replacement of equipment, shutdown of the entire substation is required. As this substation are feeding important load to the nearby areas of Badarpur in Assam, taking long shutdown would affect the power supply in these areas. Also, there are space constraints in the upgradation of the bus bar scheme. Upgradation of Badarpur (POWERGRID) substation may be taken up in Green GIS for new technology adoption in the Indian power system. Therefore, upgradation of the bus scheme in GIS may be taken up as this would help in parallel working in the substation without interrupting the power supply for longer time in these areas. Further, there is also heavy pollution due to nearby cement factory. Upgradation of the bus schemes in GIS would allow additional space for future interconnections. Upgradation of Badarpur (POWERGRID) substation may be taken up in Green GIS for new technology adoption in the Indian power system.

Thus, following scope of works was agreed in the 16th CMETS-NER held on 24-02-2023:

- (a) Upgradation of Single Main and Transfer Bus to Double Bus arrangement with Green GIS at 132kV Badarpur (POWERGRID) switching station

Implementation timeframe: 30 months from date of allocation.

8.5 Measures Taken for Mitigation of The Issues of Previous Rolling Plans

Only two constraints was reported in ISTS under N-1 contingency in the interim rolling plan of 2027-28.

- (i) Kopili – Khandong 132kV 2xS/c line was loaded upto 107MW (127% of its thermal rating) under N-1 contingency. Accordingly, reconductoring the both the circuits is being carried out under NERES-XX scheme which is expected to be completed by Nov 2024.
- (ii) Misa – Balipara 400kV D/c line was under the boundary condition and the reconductoring of the same would be taken up at a suitable time.

The constraints in the STU network needs to be assessed by respective states and suitable strengthening may be taken up by them as and when required.

8.6 System Study Results and Analysis

Based on the load-generation scenarios as elaborated in **Chapter 3**, various system studies have been carried out in PSSE. Planned/ Under implementation Transmission system that are expected to be commissioned in 2027-28 timeframe are considered for conducting these studies. Results of these studies were analysed and the same are deliberated below

8.6.1 Power Flow Analysis

a) Transmission Lines

In the base case file prepared for 2027-28 timeframe, no ISTS lines is observed to be loaded more than 70% of the thermal limit of the line.

Further, 6 nos. of STU circuits (2 no AEGCL, 1 no DoP,AP and 3 nos. MePTCL) are observed to be loaded beyond 70% of their thermal rating in the base case. Scenarios where loading is more than 70% of rating and maximum loading obtained on these transmission lines in the simulation studies are tabulated below at **Table 8-7**.

Table 8-7: Transmission Lines Loading in the Base Cases

(All Fig in MW)

Sl. No.	Name of the Line	Scenario No.	Owner	Maximum Loading	Rating (MW)
1.	Khumtai - Mariani-Assm 220kV Line-1	1,4,7	AEGCL	172	200
2.	Khumtai - Mariani-Assm 220kV Line-2	1,4,7	AEGCL	172	200
3.	Khupi - Kimi-Kameng 132kV Line-1	2	DoP, AP	59	84
4.	Khlieriat-ME - Mustem 132kV Line-1	5	MePTCL	63	84
5.	Leshka-MLHEP - Mynkre 132kV Line-1	2,5	MePTCL	60	84
6.	Leshka-MLHEP - Mynkre 132kV Line-2	2,5	MePTCL	60	84

b) Transformers

In the base case file prepared for 2027-28 timeframe, neither ISTS nor STU ICTs are observed to be loaded beyond 80% of thermal rating in the base case.

c) Voltage Analysis

PU voltages of all 132kV and above buses were observed in all the nine scenarios. Maximum and minimum voltage of each bus were identified from the bus voltages in the nine number of scenarios. It has been observed that all buses at 132kV and above are having voltage between 0.95 pu and 1.05pu. There were some buses in Mizoram and Arunachal Pradesh at 132kV level intrastate system have voltage in the range of 1.05-1.07pu in Scenario-9 (Feb night off peak scenario). The same can be controlled by switching off the capacitors at 132kV level.

8.6.2 Contingency Analysis

Contingency analysis has been performed on all the 132kV and above transmission lines & transformers to ascertain the loading levels under outage of any other 132kV & above transmission element. Results of the analysis are discussed below:

a) Transmission Lines

No ISTS lines are observed to be loaded beyond 100% of thermal rating under N-1 contingency.

Further, some of the STU lines which are observed to be loaded beyond 100% of thermal rating under N-1 contingency are summarized below at **Table 8-8**.

Table 8-8: STU Transmission lines not meeting N-1 Criteria in NER

(All Fig in MW)

Sl. No.	Name of the Line	Contingency	Scenario No.	Owner	Base case Loading	Loading under N-1	Rating	% Loading
1.	BTPS – Kokrajhar 132kV line-1	Gossaigaon – Agamoni 132kV line-1	2	AEGCL	48	85	84	101%
2.	Gossaigaon – Agamoni 132kV line-1	BTPS – Kokrajhar 132kV line-1	2	AEGCL	36	88	84	104%
3.	Chabua – Tinsukia 132kV line-1	LTPS Lakwa – Moran 132kV line-1	2	AEGCL	43	91	84	108%
4.	LTPS Lakwa – Moran 132kV line-1	Chabua – Tinsukia 132kV line-1	2	AEGCL	45	91	84	108%
5.	Khumtai – Mariani 220kV line-1	Khumtai – Mariani 220kV line-2	1,4,7	AEGCL	183	266	200	133%
6.	Khlieriat – Mynkre 132kV line-1	Khlieriat – Mynkre 132kV line-2	1,2,3,4,5,6	MePTCL	57	112	84	133%
7.	Leshka HEP – Mynkre 132kV line-1	Leshka HEP – Mynkre 132kV line-2	1,2,3,4,5,6,8	MePTCL	60	119	84	142%
8.	Dimapur PG-Dimapur 132kV line-1	Dimapur PG-Dimapur 132kV line-2	1,2, 5,8	ISTS + DoP Nagaland	56	112	84	133%

From the above table, it is seen that 5 nos. of 132kV and 220kV lines of AEGCL is violating N-1 contingency criteria. Transmission lines of MePTCL (2 lines) and DoP, Nagaland (1 line) are also found to be loaded substantially. Accordingly, STUs are advised to initiate actions to mitigate these overloads in a time bound manner.

b) Transformers

Neither ISTS nor STU ICTs are observed to be loaded beyond 100% of MVA rating under N-1 contingency.

8.6.3 Short Circuit Analysis

Short circuit level was calculated for all 132kV and above buses of North Eastern Region and it was observed that no 132kV and above buses were crossing their designed limit.

Page intentionally left blank

Chapter 9: Cross-Border Interconnection

Due to geographical location, India shares its boundaries with many South Asian countries and can play an important role in exchange of power to these countries for optimal utilisation of resources in particular and development of economy in general. Transmission of power is economical than transportation of fuel. Towards this, it is important to establish electrical interconnections with neighbouring countries which would be beneficial in meeting growing power demand, sharing of various types of energy resources, decreasing operational cost through better resource management, utilizing renewable energy resources and deferring investment by optimizing spinning reserve.

The details of existing, under-construction and under-discussion interconnections with the neighbouring countries viz. Bangladesh, Bhutan, Myanmar and Nepal with Indian grid to facilitate transfer of power for the benefit of both sides is given below:

9.1 India-Bangladesh

(i) Present interconnection

- 1160MW is being transferred to Bangladesh through following two links:
 - *1000MW through Baharampur (India) – Bheramara (Bangladesh) 400kV 2xD/c line along with 2x500MW HVDC Back-to-Back terminal at Bheramara.*
 - *160MW through Surajmaninagar (Tripura) – North Comilla (Bangladesh) – South Comilla 400kV D/c radial interconnection (operated at 132kV).*

(ii) Planned interconnection

- *Katihar (Bihar) – Parbotipur (Bangladesh) – Bornagar (Assam) 765kV D/c line*
India is going ahead with the financing and construction of the entire cross border link. The Bangladesh side may synchronize through this link at Parbotipur at an appropriate time for 1000MW drawl of power.

9.2 India-Bhutan

(i) Present interconnection

- 2070MW is being transferred from Bhutan to India through following lines in synchronous mode of operation
 - *Kurichu HEP – Geylephu (Bhutan) – Salakati 132kV S/c*
 - *Deothang/Motonga – Rangia 132kV S/c*
 - *Chukha HEP – Birpara 220kV (3 circuits)*
 - *Tala HEP – Siliguri 400kV 2xD/c*
 - *Jigmeling – Alipurduar (via Punatsangchhu) 400kV D/c (Quad) line*
 - *Jigmeling (Bhutan) – Alipurduar 400kV D/c (Quad) line*

(ii) Under Construction interconnection

- With the commissioning of Punatsangchu-I and II generation by 2024-25, the power transfer capacity would increase to about 4290MW.

9.3 India-Myanmar(i) Present interconnection

- About 2-3 MW power is being supplied to Tamu (Myanmar) from Moreh (Manipur) 33/11kV, 5MVA substation through 11kV line in radial mode.

(ii) Under Discussion interconnection

- Imphal (India) - Tamu (Myanmar) high capacity AC line along with 1x500MW HVDC back-to-back
- Nampong (Arunachal Pradesh, India) - Pansong (Myanmar) 11kV S/c radial line
- Behiang (Manipur, India) - Cikha (Myanmar) 11kV S/c radial line
- Zokhawthar (Mizoram, India) - Rikhawdar (Myanmar) 11kV S/c radial line
- Various 11kV S/c lines from Nagaland, India to Myanmar

9.4 India-Nepal(i) Present interconnection

- 1200MW can be transferred from India to Nepal through following links in radial mode of operation:
 - *About 350-400MW through 132kV & below radial lines*
 - *About 800MW of power through the first high-capacity link i.e., 400kV D/c Dhalkebar (Nepal) – Muzaffarpur (India) line.*

(ii) Under Construction interconnection

- Additional 1900MW can be transferred from Nepal to India through following links:
 - Sitamarhi (POWERGRID) – Dhalkebar (Nepal) 400kV D/c (Quad) line (associated with Arun-3 HEP, Nepal): Expected by May 2023 – 800MW
 - Gorakhpur (India) – New Butwal (Nepal) 400kV D/c (Quad) line: Requisite approvals are being obtained to take up implementation. – 1000MW
- 2nd circuit stringing of Kataiya (India) – Kusaha (Nepal) 132kV S/c on D/c line – 50MW
- 2nd circuit stringing of Raxaul (India) – Parwanipur (Nepal) 132kV S/c on D/c line - 50MW

(iii) Under Discussion interconnection

- New Purnea (India) - New Duhabi (Nepal) 400kV (Quad) D/c line – 1500MW
- Bareilly New (India) - Lumki (Nepal) 400kV (Quad) D/c line – 1500MW
- Lucknow (India) – Kohalpur (Nepal) 400kV (Quad) D/c line – 1500MW
- Nanpara (India) - Kohlapur (Nepal) 132kV D/c line – 35MW
- New Nautanwa (India) - Mainhiya (Nepal) 132kV D/c line – 35MW

9.5 India-Sri Lanka(i) Under Discussion interconnection

- New Madurai – New Habarana 2x500MW HVDC Bipole line (only 1st block of 500MW under discussion)

The cross-border transmission capacity of India with neighbouring countries in present time-frame and through under construction interconnections is summarized below in **Table 9-1**:

Table 9-1: Cross-border power transfer capacity by 2027-28

(All fig in MW)

Country	Existing	Under Construction	Planned	Total
India-Bangladesh	1160	0	1000	2160
India-Bhutan	2070	2220	0	4290
India-Myanmar	3	0	505	508
India-Nepal	1200	1900	4570	7670
India-Sri Lanka	0	0	500	500
Total	4433	4120	6575	15128

A schematic of the existing, under-construction and proposed cross-border interconnections is given in **Figure 9-1** below:

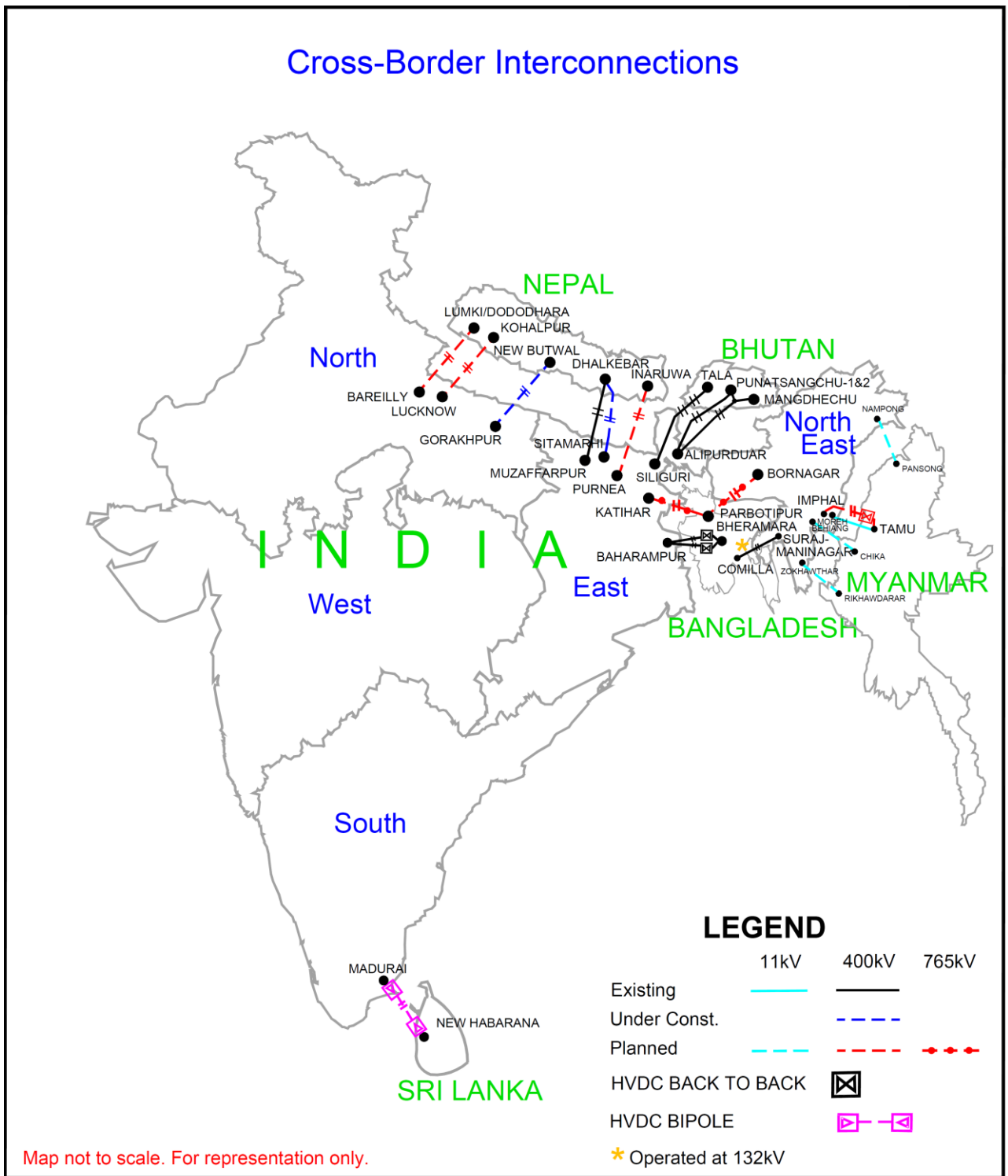

Figure 9-1: Cross-Border interconnections

Chapter 10: Planning under General Network Access (GNA)

10.1 Background

Central Electricity Regulatory Commission (Connectivity and General Network Access to the inter-State Transmission System) Regulations, 2022 were notified on 07th June 2022 and Detailed Procedure for Connectivity and GNA was also approved by Hon’ble commission on 14th October 2022. Further Draft Central Electricity Regulatory Commission (Connectivity and General Network Access to the Inter-State Transmission System) (First Amendment) Regulations, 2023 were also notified on 27th January 2023, which are under finalisation.

10.2 Introduction

Before understanding GNA it is pertinent to understand how the open access application were processed under Connectivity Regulations, 2009 and system studies performed for processing these applications.

1.2.1. Products for open Access to ISTS

In the Connectivity Regulations, 2009 application for connectivity and LTA were made by two separate applications. Connectivity application was just for connecting with the ISTS system and it does not offer any rights for exchange of power with grid. For evacuation of power through ISTS on long term basis, LTA application was required. Accordingly, ISTS planning was primarily triggered by LTA applications, where source of injection and drawal was known. Accordingly, power system was planned for point to point power transfer. In Figure below shows point to point connection between generator and drawal entity.

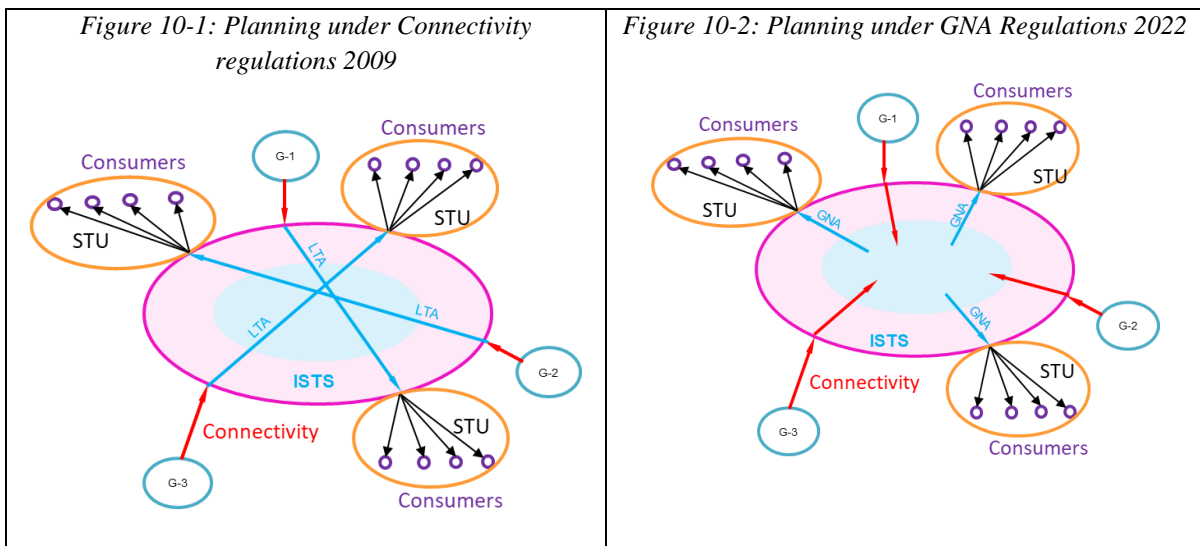

In GNA Regulations, 2022 three products have been introduced for applying open access to ISTS as under-

- a) Connectivity – Injecting Entities
- b) GNA – mainly for Drawal Entities
- c) T-GNA – mainly for Drawal Entities

Injecting entities shall apply only for connectivity and shall be granted GNA equal to quantum of connectivity, whereas drawee entities shall apply only for GNA, which shall include connectivity as well. A generator in its application shall not indicate that who are its intended beneficiaries. Similarly, drawee entities shall not mention in their applications from where they are going to procure their power. A flexibility has been provided under GNA regulation for drawee entities to procure power from cheapest available resources. In GNA, injection and drawee entities are not identified to plan point to point ISTS network. Same has been depicted in figure 1-2 vis a vis Connectivity Regulations 2009.

1.2.2. Key Highlights about GNA Regulations

Some of the important highlights of GNA Regulations are mentioned as under-

- Enabling power transfer from any point to any point
- Flexibility to the buying/selling entity to enter into different type of contracts
- Buyers to have scheduling flexibility based on merit order within their GNA
- Connectivity & GNA granted for same quantum
- Buying entities to pay transmission charges; explicitly recognized

1.2.3. Enabling Provisions of GNA Regulations

Some of the enabling provision, which were not part of the Connectivity Regulations, 2009 and included in GNA regulations, are detailed below-

1. **Enabling Energy Storage System** - Flexibility in installing ESS with Generating stations including REGS has been introduced
2. **Connectivity through existing Electrical System of Generator** - Enable any REGS/ESS to utilize the electrical system of existing Generator for connectivity.
3. **Transfer of Connectivity** - The transfer of connectivity to the companies has been simplified by allowing the transfer of the part after COD
4. **Dual Connectivity** - Dual connectivity to both intra-state and inter-state transmission system is enabled
5. **Connectivity for Bulk Consumer** - Clarity provided regarding entity who can construct the dedicated transmission line for Bulk Consumer.
6. **Enabling Auxiliary Power drawal** - GNA to transmission licenses for drawal of auxiliary power is allowed.

10.3 System Study in GNA

From System Study point of view, two types of studies to be performed by CTU has been mentioned in GNA Regulations-

1. For Grant of Connectivity

These studies shall be performed every month for application received for ISTS connectivity from injecting entities. The objective of these studies shall be to identify interconnection requirements.

2. For Grant of GNA

These studies shall be performed every year for application received for grant of GNA to STUs for next three financial years. The objective of these studies shall be to identify augmentation required for drawl of power by states for next three financial years. Further these studies shall also be performed for drawl entities other than STUs as per their applications in between the year for grant of GNA.

10.4 Procedure for System Studies

In order to carryout system studies for grant of GNA (including additional quantum), preparation of Load-Generation Balance (LGB) is the foremost requirement. The methodology for preparation of LGB is given below. The schematic diagram showing GNA requirement of states and entities from ISTS including segregation of within and outside region is shown as under.

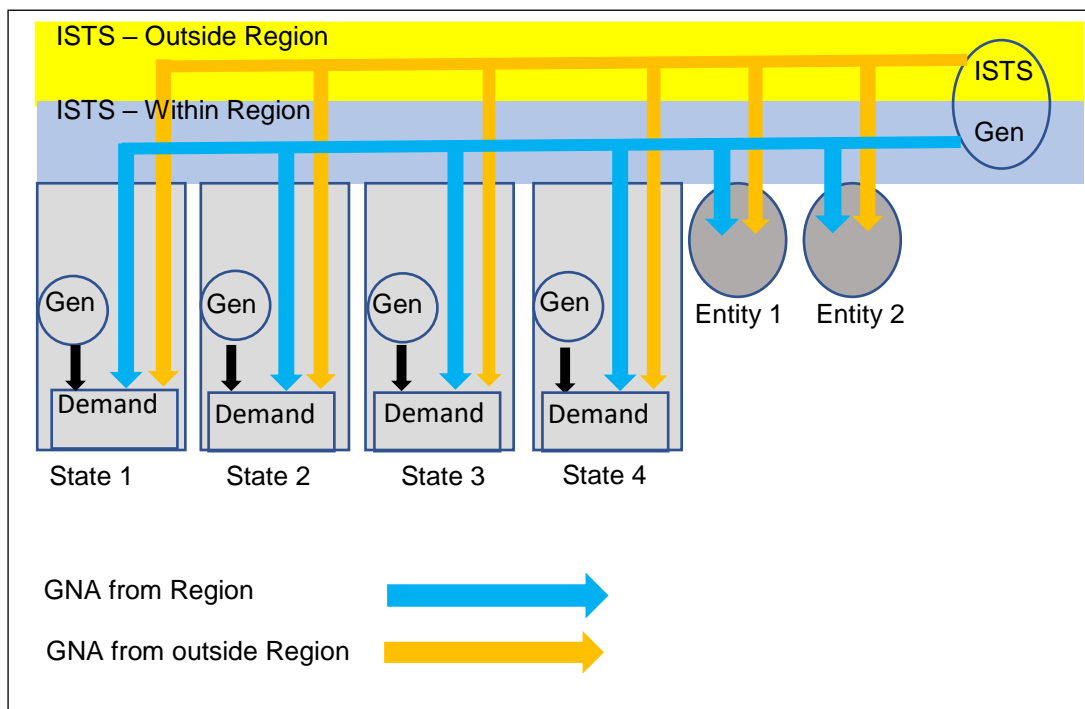

Figure 10-3: Depiction of GNA within and outside the region

In addition to the GNA requests, states would also need to provide their demand figures for future years keeping in view the EPS (published by CEA) projections. Based on the inputs from states and entities, all India LGB shall be prepared. A sample All India LGB in regard is given as under:

Region	*Demand	ISTS Drawal (GNA)	Intra-state Gen	GNA met from Within Region	GNA met from Outside Region	Distribution of total in E among regions	Regional Generation	Surplus/ Deficit
	A	B	C=A-B	D	E	F	G=C+D+F	H=G-A
NR	85,930	37,992	47,938	24,956	13,036	7,944	80,838	-5,092
WR	79,251	26,114	53,137	22,285	3,831	7,094	82,516	3,265
SR	70,692	27,287	43,405	20,888	6,398	6,649	70,942	250
ER	34,918	13,322	21,596	11,029	2,293	3,511	36,136	1,218
NER	5,095	2,646	2,449	2,279	366	726	5,454	359
All India	2,75,886	1,07,361	1,68,525	81,437	25,924	25,924	2,75,886	0

Note:

- (a) *Regional demand shall be sum of peak demands of all states within the region.
- (b) F column may be prepared through distribution of total under E column on merit order basis. For simplicity, in the present case, E column is distributed in proportion to D column.

Pictorial depiction of a sample Southern Region LGB as per Deemed GNA quantum is as under:

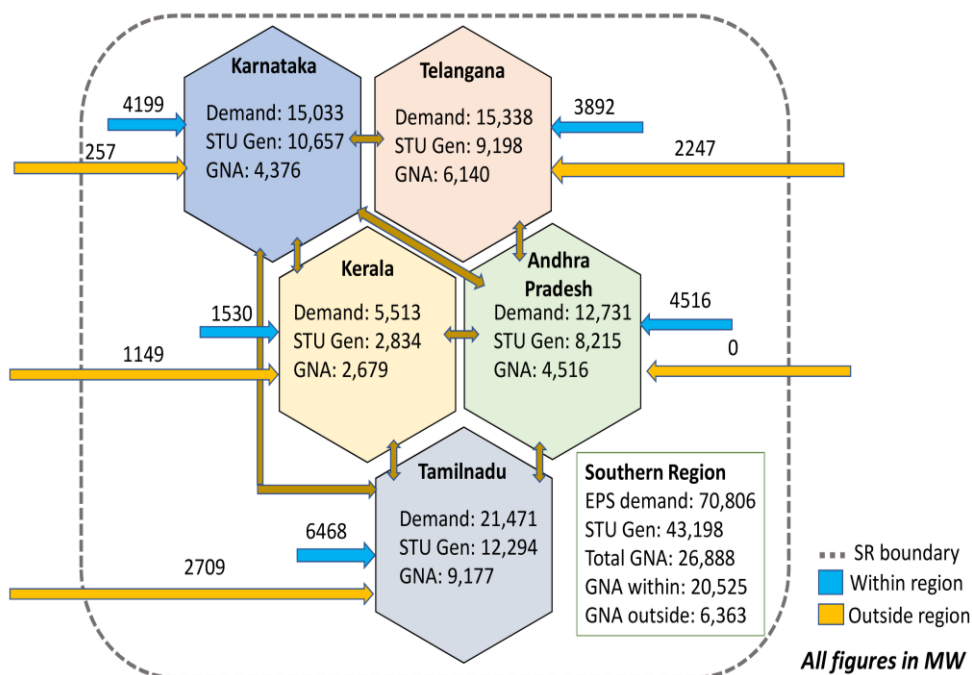

$$\text{Regional (SR) generation} = 43198 + 20525 + G(\text{OR})$$

System studies for processing GNA requests (including additional quantum) shall be carried out as proposed below:

- a) Based on the above LGB, All India peak demand base cases with different generation patterns (like peak solar, off-peak solar etc.) for a year shall be prepared considering the following:
- States demand corresponding to peak demand scenario shall be set in base case. Substation wise load distribution within a state shall be provided/verified by respective STU. Intra-state generations (C) shall be dispatched based on inputs from respective states.
 - ISTS generation within the region (thermal portion of D) shall be dispatched based on merit order of thermal units. Outside the region thermal generation requirements on a pan India basis in ISTS (thermal portion of E) shall be dispatched on a merit order basis among all ISTS connected generations.
 - Other generations (within region) shall be dispatched as per CEA's Manual on Transmission Planning Criteria.
 - Expected transmission system and generation addition in ISTS and Intra-state (as per inputs from STUs) will be considered.
- b) Load flow including Contingency studies for ISTS shall be carried out in accordance with Manual on Transmission Planning Criteria to assess the feasibility of transferring requisite power to all the states at all India level. Based on study results and observations, detailed studies shall also be carried out at each Regional level for processing and grant of GNA (including additional quantum) to states within the region. While doing regional level studies, flexibility of obtaining of outside region GNA quantum from various regions/generation complexes may also be considered. For this, as desirable, various credible contingencies to meet the GNA requirement from different combination of generation despatches/complexes within and outside the region would be studied.
- c) In case there is a constraint observed in grant of the desired quantum of additional GNA to all states of a region, then additional GNA quantum shall be granted on pro-rata basis of requested quantum considering available transmission import capability of region from the ISTS system.
- d) Total GNA of a state shall be sum of already granted GNA and additional GNA granted. This shall be basis for further studies.

10.5 Transition Under GNA

As per GNA Regulations there are provisions regarding arrangement of transition for all the connectivity/LTA/MTOA grantees from Connectivity Regulation 2009 to GNA Regulations 2022. To understand a transition process, let's take a typical example of a generator having 850 MW of connectivity granted. Out of that 850 MW of connectivity granted 660 MW is effective means it is commissioned and connected to grid. Out of these 660 MW of connectivity effective LTA has been applied and granted only for 600 MW. Out of that 600 MW LTA granted, 400 MW LTA is effective i.e. 100 MW with firm beneficiaries and 300

MW on target basis as on date of coming into force of these regulations. Status of various quantum of connectivity is depicted below in figure -

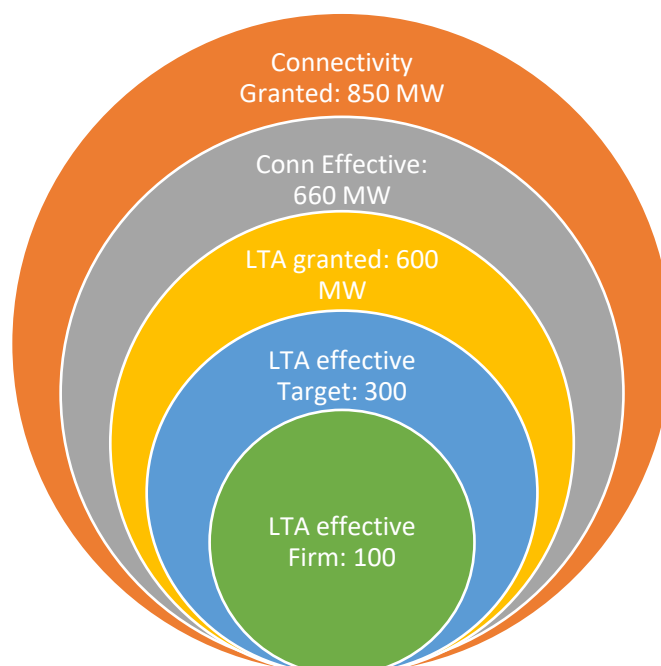

Figure 10-4: Distribution of quantum of generation

Considering this aspect and to take care transition requirement of various quantum of connectivity, broadly 9 no. of categories of grantees/applicants based on their status of connectivity, LTA or MTOA in extant Connectivity Regulations 2022 as on date of coming into force of GNA Regulations are mentioned below-

1. Connectivity/LTA/MTOA applicants- Application received till the date of coming into effect of these regulation, which have not been granted connectivity/LTA/MTOA.
2. Connectivity granted but no LTA granted and Connectivity is not effective
3. LTA granted but not effective
4. MTOA granted but not effective
5. LTA and MTOA granted to Traders
6. Connectivity granted is effective and LTA is granted or not granted
7. LTA effective with target beneficiary-
8. LTA effective with firm beneficiaries- Deemed GNA
9. MTOA granted and effective

Treatment for different quantum of generation capacity as per GNA regulation is depicted in figure and table below-

Sr. No.	Quantum	Treatment
1	100	Deemed GNA
2	300	Convert LTA to GNA under 37.6 by submitting Conn-BG3@ 2 lakhs/MW
3	200	Convert LTA to GNA under 37.3
4	60	Apply for additional GNA under 17.2
5	190	Convert connectivity granted to Connectivity under GNA Reg. under 37.2

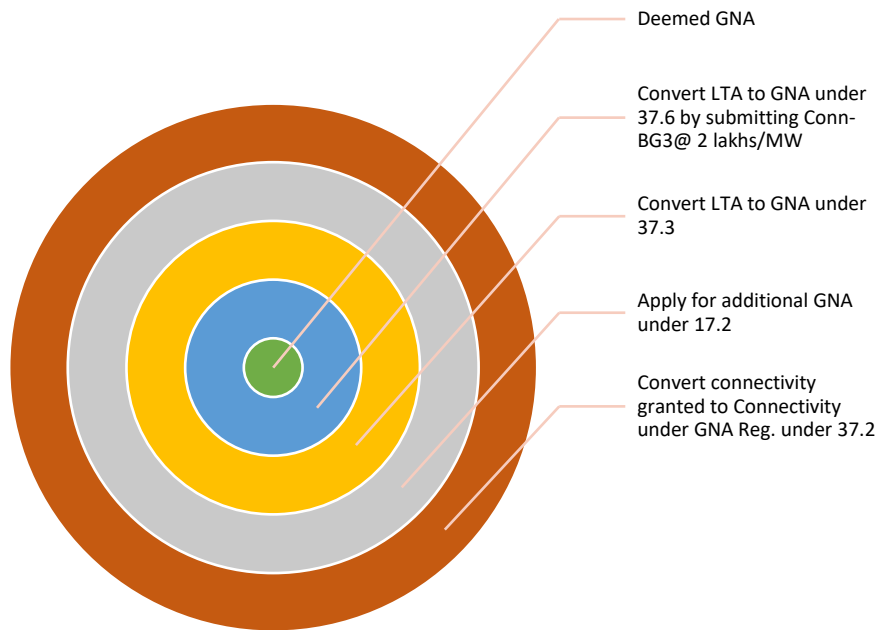

Figure 10-5: Conversion of quantum of generation in GNA

Considering the open access granted at ISTS level to various generating units across India having, a total of about 240 GW quantum is going under transition. By virtue of having firm beneficiaries for this generation quantum of about 53% of 240 GW will get transitioned to as deemed GNA. About 20% of this quantum is just having connectivity and not having any LTA against that quantum. About 15% of this quantum is having LTA granted which has not yet become effective. A pie chart in this reference is shown in figure.

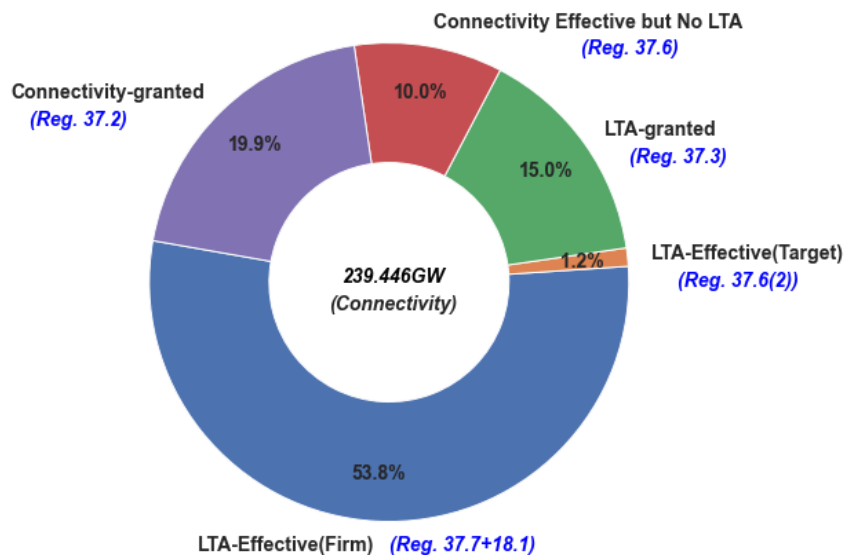

Figure 10-6: Break up of total generation for transition under GNA

Page intentionally left blank

Chapter 11: Conclusion

The installed capacity of generation in Indian grid is expected to increase to about 702 GW by 2027-28 from 412 GW as on Feb'23. It will witness an increase in contribution of non-fossil fuel-based energy sources from 42% to 59%, whereas contribution of fossil fuel-based energy source will see a decline from 58% to 37% in total installed capacity in same timeframe. Renewable generation alone is expected to see an increase of around 175% by 2027-28 from current time-frame. This will create a pathway for India's commitment in COP26, wherein India is projected to have total installed capacity of non-fossil fuel-based generation of 500GW by the year 2030.

Power scenario of the country is quite diverse and varies continuously. RE integration with grid further enhance its complexity. Large RE complexes are expected to be established in Northern, Western, and Southern regions by 2027-28 time-frame. The transmission system for integrating the same into the grid has already been planned and is currently under various stages of approval/implementation. As substantial solar generation addition has been envisaged in Rajasthan, this has resulted in NR becoming exporter of power around noon solar max period and importer during the evening peak demand period, in all seasons. Similar situations have been witnessed in other regions as well i.e. the region is surplus under certain load-generation scenario and deficit in other. To study the seasonal and diurnal variations of generations including demand, load generation balance has been prepared for three seasons (Monsoon, Summer, and Winter) in a year with three load conditions (Solar max, Evening peak demand, and Night off-peak demand) of daily load curve for each season. All India maximum and minimum demand of 294 GW and 162 GW has been considered while working out the LGBs for 2027-28 timeframe. Out of these nine scenarios, the most crucial ones from transmission planning point of view are three scenarios viz. highest all India demand (Scenario-1), highest RE generation (Scenario-4), and lowest all India demand (Scenario-9).

While preparing the LGB, it has been observed that to dispatch maximum RE generation during the noon time, on bar thermal units required to meet evening peak demand are to be operated below the present technical minimum of 55%. If thermal units are to be operated at 55% of technical minimum during the Solar max period, then 46 GW, 61 GW and 34 GW of surplus generation would be available in Monsoon, Summer and Winter season respectively after meeting the all-India demand and energy storage requirement in 2027-28 time-frame. If technical minimum of thermal units is reduced to 40%, then surplus generation reduces to 27 GW, 42 GW and 6 GW in Monsoon, Summer and Winter seasons respectively. This study also highlights the need of energy storage in the grid to facilitate the RE integration by 2027-28. As of now, the portion of energy and peak demand met by RE as compared to total requirement is quite low. However, this will not be the case of future when a large quantum of RE will integrate with grid.

Various system studies and analysis have been conducted like power flow, contingency and short-circuit studies on All India basis as well as on Regional basis to evaluate and evolve new transmission system for 2027-28 timeframe. This caters to a power transmission network

planned in a manner that offers techno-feasible solution considering all the aspects without compromising the security, reliability and robustness of National Grid.

Load flow including N-1 contingency studies have been conducted for all scenarios to check and analyse the power flow pattern on EHV transmission lines and inter connecting transformers. During the studies it was observed that most of the transmission lines and transformers loading are within limits except for few cases which are highlighted in report and their detailed analysis is included in regional chapters. Further mitigation measures required, if any, for addressing loading observed beyond limit shall be taken care in subsequent transmission planning exercises. Bus voltages at 765kV and 400kV have also been analysed for all the scenarios and voltages beyond the permissible limits are highlighted in the report. Most of bus voltages are found to be within the range and by adopting suitable grid operating mechanisms, the voltage can be controlled. Nevertheless, more reactive power management devices are also being planned for installation in areas having over/under voltages.

Short circuit studies have also been performed on all the scenarios and fault MVA violations at 765kV and 400kV beyond the design rating are also highlighted in the report. Fault level at many of the 400 kV buses including the STU and generating station buses are observed to be beyond the design limits. Measures like bus split, bypassing of the lines and installation of series reactor to control the fault MVA level are under planning at ISTS buses. However, same also needs to be taken up at STU and generating station level by respective utilities.

In summary, existing and planned/proposed transmission network is found to be adequate for meeting the demand and integrating anticipated generation to be commissioned by 2027-28 timeframe. Further, basic network parameters of the Indian grid are within their operating limits except for few cases which are being studied in detail and necessary mitigation measures will be published in the subsequent Rolling Plan report.

In this Rolling Plan, transmission schemes of about 15,150 ckm of transmission lines and 1,90,615 MVA of transformation capacity has been formulated at an estimated cost of Rs. 1,10,635 Cr for addition into the grid. Cumulatively by 2027-28, transmission schemes comprising of 42,215 ckm of transmission lines and transformation capacity of 3,89,925 MVA at estimated cost of Rs 2,24,237 Cr. is expected to be added in the grid.

Brief of transmission systems and observations from system studies for each region are as below:

Northern Region (NR)

The total installed generation capacity of NR as on Feb'23 is about 117 GW which constitute capacity from fossil sources (46% share) & balance (54% share) from Non-fossil sources in which (53%) contribution in total regional IC is from renewable generation capacity including hydro and balance (1%) is from nuclear.

NR is connected to WR and ER through 765kV & 400kV high capacity corridors along with HVDC Back to Back / HVDC Bipoles. The thermal generating stations of NR are

predominantly located in Uttar Pradesh, Punjab, Rajasthan and Haryana, whereas hydro generation is concentrated in Jammu & Kashmir, Himachal Pradesh and Uttarakhand. Further, Rajasthan is a RE rich state comprising of large Solar & Wind capacity.

To meet the growing demand, NR is continuously progressing in generation capacity addition majorly through hydro and non-conventional/renewable sources. As per the 20th EPS, NR demand for 2027-28 timeframe is expected to increase to about 103 GW. As per the inputs received from various stakeholders, total installed capacity of NR for 2027-28 is expected to be about 200 GW.

Various transmission schemes i.e. Scheme to relieve high loading of 400 kV Bhinmal -Zerda line (WR-NR IR scheme), transmission system for evacuation of power from Rajasthan REZ Ph-IV (Part-1) (Bikaner Complex) and Ph-IV (Part-2 : 7.5GW) (Jaisalmer/Barmer Complex), transmission system for evacuation of power from Shongtong Karcham HEP (450MW) and Tidong HEP (150 MW), Augmentation of ICTs at RE pooling substations to take care N-1 Contingency, line reactors to address high voltages and enhancement of ATC/TTC for Punjab due to unprecedented load growth of summer/ paddy season planned in the Consultation Meeting for Evolution of Transmission System in Northern Region (CMETS-NR) from Mar'22 to Feb'23 for implementation. In this Rolling Plan, transmission schemes of about 3,650 ckm of transmission lines and 46,065 MVA of transformation capacity has been formulated at an estimated cost of Rs. 29,987 Cr.

For mitigation of the issues highlighted in Rolling Plan of 2026-27-time frame, some of augmentation works have been identified in ISTS and in STU network. Same was discussed in the Joint Study /CMETS-NR meetings i.e. Implementation of N -1 contingency at RE pooling substations in NR, Enhancement of ATC/TTC for Punjab have been evolved in NR to relieve overloadings on ICTs. These schemes either been approved or under various stages of approval. Similarly, a few ISTS have also been evolved to resolve import capability, overloading issues and to meet the growing demands of the states. Further, new expansions in Northern Region are being taken up on a continuous basis and the mitigation measures identified would be taken up for detailed analysis in the subsequent rolling plan.

Thus, cumulatively by 2027-28, transmission schemes comprising of 18,736 ckm of transmission lines and transformation capacity of 1,30,135 MVA at estimated cost of Rs 1,03,594 Cr. is expected to be added in the grid.

Western Region (WR)

The total installed generation capacity of WR as on Feb'23 is about 134GW which constitute capacity from fossil sources (65% share) & balance (35% share) from Non-fossil sources in which (34%) contribution in total regional IC is from renewable generation capacity including hydro and balance (1%) is from nuclear.

Western Region is connected to Northern, Southern and Eastern Regions through 765kV & 400kV high-capacity corridors along with Back to Back HVDCs and Bi-Pole HVDC links. The thermal generating stations of Western Regions are predominantly concentrated in the

coal rich states of Chhattisgarh, Eastern part of Maharashtra and Madhya Pradesh. Further, Gujarat, Maharashtra and Madhya Pradesh are RE rich states comprising of large Solar & Wind capacity. Western part of Maharashtra, southern Gujarat and DD & DNH have high demand and less internal generation.

To meet the growing demand, Western region is continuously progressing in generation capacity addition majorly through thermal and non-conventional/renewable sources. The peak demand of Western Region for 2027-28 timeframe is expected to increase to about 95 GW. As per the inputs received from various stakeholders, total installed capacity of Western Region for 2027-28 is expected to be about 207 GW.

Various transmission systems have been evolved in the Consultation Meeting for Evolution of Transmission System in WR (CMETS-WR) from Mar'22 to Feb'23 for implementation. These schemes have either been approved or are under various stages of approval. For integration of additional RE potential in Neemuch (2GW), Solapur (1GW), Dhule (2GW), Kallam & Parli (2GW), the transmission schemes have been evolved and under finalisation. Further, Transmission system for evacuation of additional 30 GW RE power from Khavda RE park has been evolved and is under approval and is expected to play a major role in fulfilling India's vision of generating 500 GW of non-fossil generation capacity by 2030.

For mitigation of the issues highlighted in Rolling Plan of 2026-27-time frame, augmentation works have been discussed with the STUs in the Joint Study /CMETS-WR meetings. In this respect, Western Region Expansion Scheme XXXI Part A to Part C have been evolved in Maharashtra to relieve overloadings on ICTs/lines & short circuit constraints. Further, network expansion schemes in MP has also been evolved to meet the future ISTS drawal requirement of MP. In this Rolling Plan, transmission schemes of about 7,270 ckm of transmission lines and 71,000 MVA of transformation capacity has been formulated at an estimated cost of Rs. 56,937 Cr.

Similarly, a few ISTS and Intra-state schemes have also been evolved in Maharashtra & Madhya Pradesh to resolve import capability, overloading issues and to meet the growing demands of the states. Further, new network expansions in Western Region are being taken up on a continuous basis and the mitigation measures identified would be taken up for detailed analysis in the subsequent rolling plan.

Thus, cumulatively by 2027-28, transmission schemes comprising of 13,105 ckm of transmission lines and transformation capacity of 1,32,000 MVA at estimated cost of Rs 77,630 Cr. is expected to be added in the grid.

ISTS and Intra-State strengthening required to mitigate the issues highlighted in the current rolling plan are also under planning and would be taken up for implementation after detailed analysis.

Southern Region (SR)

The total installed generation capacity of SR as on Feb'23 is about 122 GW which constitute capacity from fossil sources (47% share) & balance (53% share) from Non-fossil sources in

which (50%) contribution in total regional IC is from renewable generation capacity including hydro and balance (3%) is from nuclear.

Southern Region is connected to Western and Eastern regions through high capacity 765kV AC links, Back-to-Back HVDC and Bi-pole HVDC links. The thermal generating stations of Southern Region are predominantly concentrated in the States of Tamil Nadu, Karnataka, Andhra Pradesh and Telangana. Further, Tamil Nadu, Karnataka and Andhra Pradesh are RE rich states comprising of largescale Solar & Wind capacity. Southern part of Karnataka (Bangalore), Kerala and Central part of Telangana (Hyderabad) has high demand and less internal generation.

To meet the growing demand, Southern region is continuously progressing in generation capacity addition majorly through thermal and non-conventional/renewable sources. Southern Region demand for 2027-28 timeframe is expected to increase to about 87 GW. As per the inputs received from various stakeholders, total installed capacity of Southern Region for 2027-28 is expected to be about 228 GW.

Various transmission systems have been evolved in the Consultation Meeting for Evolution of Transmission System in SR (CMETS-SR) from Mar'22 to Feb'23 for implementation. These schemes have either been approved or under various stages of approval. Transmission system for integration of additional RE potential of about 14.5 GW in Karnataka in Gadag, Koppal, Davangere, Bijapur and Tumkur area and RE potential of about 6.5 GW in Telangana in Nizamabad, Medak, Rangareddy have been evolved. The proposed scheme will facilitate in integration and immediate evacuation of RE potential areas of Karnataka and Telangana which are under various stages of approval. Further, Reconductoring of Raichur – Veltoor (Mahabubnagar) 400 kV S/c line with HTLS conductor has also been approved to relive the overloading of transmission line. In this Rolling Plan, transmission schemes of about 3830 ckm of transmission lines and 70,500 MVA of transformation capacity has been formulated at an estimated cost of Rs.20,501 Cr.

During the system studies for 2027-28 timeframe, few Short Circuit issues are observed in Tamil Nadu, Telangana, Karnataka and Andhra Pradesh due to large interconnections. Further, some transformers are also observed to be loaded beyond limit in Tamil Nadu, Telangana, Karnataka, Kerala and Andhra Pradesh. Most of these ICTs are located in Tamil Nadu. Some of the lines such as, Maheshwaram – Hyderabad 400kV S/c line, Cuddapah – Chittoor 400kV S/c line, Kurnool – Srisalem LB 400kV S/c line, Somanhally – Bidadi 400kV D/c line, Thiruvallur – Malekottiyar 400kV D/c line and Nizamabad – Dichipally 400kV (Quad) D/c line etc. are critically loaded under Base case / N-1 contingency. New network expansions schemes and mitigation measures to address above issues in Southern Region are being taken up on a continuous basis and would be taken up in the subsequent rolling plan after detailed analysis.

As per the timelines provided in the CEA report for integration of over 500 GW RE capacity by 2030, entire Phase-I & Phase-II potential of additional 181.5 GW RE capacity by 2030 has been considered in this Rolling Plan. Some of the transmission lines and ICTs are observed to be critically loaded at locations where RE potential is getting pooled from various pockets.

Measures to control these loadings shall be planned in coordinated manner upon materialization of the RE potential (part of 181.5 GW REZs).

Thus, cumulatively by 2027-28, transmission schemes comprising of 8,170 ckm of transmission lines and transformation capacity of 121,000 MVA at estimated cost of Rs 36,568 Cr. is expected to be added in the grid.

Eastern Region (ER)

The total installed generation capacity of ER as on Feb'23 is about 34GW which constitute capacity from fossil sources (81% share) & balance (19% share) from Non-fossil sources comprising of renewable generation capacity including hydro.

Eastern Region is connected to all other regions through 765kV & 400kV high-capacity corridors along with HVDC Back to Back/ HVDC Bipole lines. The thermal generating stations of ER are predominantly located in Bihar, Jharkhand and Odisha whereas hydro generation are concentrated primarily in Sikkim. Eastern region is also connected to other countries such as Nepal, Bhutan and Bangladesh through high-capacity AC and HVDC links.

To meet the growing demand, Eastern region is continuously progressing in generation capacity addition majorly through thermal and hydro generation sources. The peak demand of Eastern Region for 2027-28 timeframe is expected to increase to about 40 GW. As per the inputs received from various stakeholders, total installed capacity of Eastern Region for 2027-28 is expected to be about 60 GW.

Various transmission schemes such as establishment of Paradeep 765/400kV (ISTS) GIS S/s through Angul – Paradeep 765kV D/c corridor & Paradeep (ISTS) – Paradeep (OPTCL) 400kV D/c (quad) line, reconductoring of Jharsuguda – Rourkela 400kV 2xD/c line (WR-ER interconnections), reconductoring of Rangpo – Gangtok 132kV D/c line, augmentation of reactive compensation at Biharsharif, Jamshedpur, Maithon S/s have been evolved in the Consultation Meeting for Evolution of Transmission System in Eastern Region (CMETS-ER) from Mar'22 to Feb'23. In this Rolling Plan, transmission schemes of about 400 ckm of transmission lines and reconductoring of 400 ckm, 3,050 MVA of transformation capacity has been formulated at an estimated cost of Rs. 3,106 Cr. These schemes either have been approved or are under various stages of approval. Further, new network expansions in Eastern Region are being taken up on a continuous basis and the mitigation measures identified would be taken up for detailed analysis in the subsequent rolling plan.

Thus, cumulatively by 2027-28, transmission schemes comprising of 715 ckm of transmission lines and transformation capacity of 4,550 MVA at estimated cost of Rs 3,920 Cr. is expected to be added in the grid.

North Eastern Region (NER)

The total installed generation capacity of NER as on Feb'23 is about 5GW which constitute capacity from fossil sources (48% share) & balance (52% share) from Non-fossil sources comprising of renewable generation capacity including hydro.

North Eastern Region is connected to Eastern Region and North Region through 400kV high-capacity corridors along with multi-terminal HVDC. The thermal generating stations of Northern Eastern Region are located in Assam, gas generations are situated in Assam and Tripura whereas hydro generation is concentrated primarily in Arunachal, Manipur & Meghalaya.

To meet the growing demand, NER is continuously progressing in generation capacity addition majorly through hydro generation sources. The peak demand of North Eastern Region for 2027-28 timeframe is expected to increase to about 5.2 GW. As per the inputs received from various stakeholders, total installed capacity of Northern Eastern Region for 2027-28 is expected to be about 7.1 GW.

Various transmission schemes i.e. reconductoring of 132kV lines in Mizoram, Manipur and Meghalaya and upgradation of 132kV S/s from AIS to GIS have been approved in the Consultation Meeting for Evolution of Transmission System in North Eastern Region (CMETS-NER) from Mar'22 to Feb'23. In this Rolling Plan, reconductoring of about 46 ckm of transmission lines has been formulated at an estimated cost of Rs. 104 Cr. These schemes have either been approved or are under various stages of approval.

Further, evacuation of power from future hydro projects primarily in Arunachal Pradesh would be planned after firm commission schedule and significant progress in the hydro generation projects. New network expansion schemes in North Eastern Region are being taken up on a continuous basis and the mitigation measures identified would be taken up for detailed analysis in the subsequent rolling plan.

Thus, cumulatively by 2027-28, transmission schemes comprising of 1,489 ckm of transmission lines and transformation capacity of 2,240 MVA at estimated cost of Rs 2,526 Cr. is expected to be added in the grid.

Cross Border Interconnections (CB)

The existing cross-border interconnections facilitate power transfer of about 4433MW (2070MW: Bhutan, 1160MW: Bangladesh, 1200MW: Nepal and 3MW: Myanmar) with the neighbouring countries. With the commissioning of under-construction cross-border interconnections which are expected in 2-3 years, the power transfer would enhance by about 4120MW resulting in total of about 8553MW (4290MW: Bhutan, 1160MW: Bangladesh, 3100MW: Nepal and 3MW: Myanmar).

Page intentionally left blank

Annexures

Page intentionally left blank.

Annex-2.1

Load Generation Balance (LGB)

Monsoon (Aug'27)

Region	Thermal Central	Thermal State	Thermal IPP	Thermal	Nuclear	Hydro	Solar	Rooftop	Wind	Other RE	ESS	Gas	Total	EPS Peak Demand	App. Peak Demand	LTA	
	NR	11880	41838	0	53718	4420	25269	86320	4500	13401	1360	7500	3583	200070	103650	92748	0
WR	19000	34160	35602	88762	3240	6318	55675	4500	35359	0	3290	10139	207283	94748	84783	0	
SR	12870	36988	4640	54498	7820	13212	73154	4500	53852	2119	16835	1781	227770	85953	76913	0	
ER	25760	14450	4150	44360	0	13786	1103	400	0	0	900	0	60549	39847	35656	0	
NER	750	0	0	750	0	4375	100	100	0	0	0	1854	7179	5159	4616	0	
	70260	127435	44392	242087	15480	62960	216352	14000	102612	3479	28525	17356	702851	294716	294716		
		242087						399403						329357			
Scenario 1 : Solar Max Aug 2027																	
Avail	Thermal Central	Thermal State	Thermal IPP	Thermal	Nuclear	Hydro	Solar	Rooftop	Wind	Other RE	ESS	Gas		National DF	Regional DF		
NR	22%	13%	0%	28%	80%	70%	90%	0%	50%	0%	-100%	0%		92%	91%		
WR	23%	3%	16%	-2%	80%	40%	80%	0%	55%	0%	-100%	0%		88%	87%		
SR	0%	0%	9%	24%	80%	40%	80%	0%	55%	0%	-100%	0%		83%	82%		
ER	13%	12%	25%	-7%	80%	70%	80%	0%	0%	0%	-100%	0%		74%	73%		
NER	40%	0%	0%	14%	80%	70%	80%	0%	0%	0%	-100%	0%		68%	67%		
	15%	6%	16%	10%										96%	283741		
Avail	Central	State	IPP	Reqd Th	Nuclear	Hydro	Solar	olar rooftop	Wind	RE RPO	ESS	Gas	Total avail	Demand	Surplus/D	Net Avail	Net Dem
NR	2628	5588	0	15283	3536	17688	77688	0	6701	84248	-7500	0	106329	95567	10762	106329	95567
WR	4336	900	5706	-1360	2592	2527	44540	0	19447	85888	-3290	0	76758	83830	-7072	76758	83830
SR	0	0	398	13151	6256	5285	58523	0	29619	68795	-16835	0	83246	71367	11879	83246	71367
ER	3297	1692	1024	-2989	0	9650	882	0	0	33379	-900	0	15646	29490	-13844	15646	29490
NER	300	0	0	105	0	3063	80	0	0	3382	0	0	3443	3487	-45	3443	3487
Total	10561	8180	7127	24189	12384	38213	181714	0	55767	275693	-28525	0	285421	283741	1680	285421	283741
	25869						275693							280489			
32%	StateTh																
Scenario 2 : Peak load Aug 2027																	
Avail	Thermal Central	Thermal State	Thermal IPP	Thermal	Nuclear	Hydro	Solar	Rooftop	Wind	Other RE	ESS	Gas	0	National DF	Regional DF		
NR	60%	64%	0%	86%	80%	95%	0%	0%	70%	0%	60%	50%		92%	92%		
WR	62%	38%	57%	33%	80%	70%	0%	0%	75%	0%	60%	50%		84%	83%		
SR	2%	23%	23%	19%	80%	70%	0%	0%	75%	0%	60%	50%		70%	69%		
ER	29%	53%	52%	45%	80%	90%	0%	0%	0%	0%	60%	50%		91%	90%		
NER	40%	0%	0%	298%	80%	90%	0%	0%	0%	0%	60%	50%		92%	91%		
	38%	44%	53%	45%										94%	276425		
Avail	Central	State	Private	Reqd Th	Nuclear	Hydro	Solar	olar rooftop	Wind	RE RPO	ESS	Gas	Total avail	Demand	Surplus/D	Net Avail	Net Dem
NR	7115	26820	0	46128	3536	24005	0	0	9381	39821	4500	1791	77148	95776	-18627	77148	95776
WR	11696	12828	20408	29189	2592	4422	0	0	26519	40596	1974	5069	85510	79420	6090	85510	79420
SR	200	8458	1056	10334	6256	9248	0	0	40389	32517	10101	890	76598	60098	16500	76598	60098
ER	7378	7693	2176	20053	0	12407	0	0	0	15777	540	0	30194	36370	-6176	30194	36370
NER	300	0	0	2235	0	3938	0	0	0	1599	0	927	5164	4761	403	5164	4761
Total	26689	55799	23640	107938	12384	54021	0	0	76289	130310	17115	8678	274615	276425	-1810	274615	276425
	106128						130310							273996			
53%	StateTh																
Scenario 3 : off peak load Aug 2027																	
Avail	Thermal Central	Thermal State	Thermal IPP	Thermal	Nuclear	Hydro	Solar	Rooftop	Wind	Other RE	ESS	Gas		National DF	Regional DF		
NR	42%	41%	0%	47%	80%	70%	0%	0%	60%	0%	40%	50%		63%	63%		
WR	29%	18%	36%	14%	80%	40%	0%	0%	65%	0%	40%	50%		57%	56%		
SR	2%	16%	23%	18%	80%	40%	0%	0%	65%	0%	40%	50%		58%	57%		
ER	23%	39%	25%	40%	80%	70%	0%	0%	0%	0%	40%	50%		77%	77%		
NER	40%	0%	0%	136%	80%	70%	0%	0%	0%	0%	40%	50%		62%	62%		
	24%	27%	33%	27%										69%	203248		
Avail	Central	State	Private	Reqd Th	Nuclear	Hydro	Solar	olar rooftop	Wind	RE RPO	ESS	Gas	Total avail	Demand	Surplus/D	Net Avail	Net Dem
NR	5027	17166	0	25346	3536	17688	0	0	8041	31855	3000	1791	56249	65528	-9278	56249	65528
WR	5504	6037	12663	12455	2592	2527	0	0	22983	32475	1316	5069	58691	53907	4784	58691	53907
SR	200	6066	1056	9869	6256	5285	0	0	35004	26012	6734	890	61492	49761	11730	61492	49761
ER	6028	5664	1024	17847	0	9650	0	0	0	12621	360	0	22726	30828	-8102	22726	30828
NER	300	0	0	1018	0	3063	0	0	0	1279	0	927	4289	3223	1066	4289	3223
Total	17059	34934	14743	66535	12384	38213	0	0	66028	104241	11410	8678	203448	203248	200	203448	203248
	66735						104241							201679			
52%	StateTh																

Summer (Jun '27)

Region	Thermal Central	Thermal State	Thermal IPP	Thermal	Nuclear	Hydro	Solar	Rooftop	Wind	Other RE	ESS	Gas	Total	EPS Peak Demand	App. Peak Demand	LTA
	NR	11880	41838	0	53718	4420	25269	86320	4500	13401	1360	7500	3583	200070	103650	92748
WR	19000	34160	35602	88762	3240	6318	55675	4500	35359	0	3290	10139	207283	94748	84783	0
SR	12870	36988	4640	54498	7820	13212	73154	4500	53852	2119	16835	1781	227770	85953	76913	0
ER	25760	14450	4150	44360	0	13786	1103	400	0	0	900	0	60549	39847	35656	0
NER	750	0	0	750	0	4375	100	100	0	0	0	1854	7179	5159	4616	0
Total	70260	127435	44392	242087	15480	62960	216352	14000	102612	3479	28525	17356	702851	294716	294716	
		242087					399403							329357		

Scenario 4 : Solar Max Jun 2027	Avail	Thermal Central	Thermal State	Thermal IPP	Thermal	Nuclear	Hydro	Solar	Rooftop	Wind	Other RE	ESS	Gas	Total avail	National DF	Regional DF
NR	18%	8%	0%	28%	80%	70%	90%	0%	50%	0%	0%	-100%	0%		94%	93%
WR	11%	1%	10%	-16%	80%	40%	85%	0%	55%	0%	0%	-100%	0%		77%	76%
SR	0%	0%	0%	23%	80%	40%	85%	0%	55%	0%	0%	-100%	0%		84%	83%
ER	4%	4%	25%	-7%	80%	70%	85%	0%	0%	0%	0%	-100%	0%		75%	74%
NER	40%	0%	0%	-29%	80%	70%	85%	0%	0%	0%	0%	-100%	0%		63%	62%
Total	8%	3%	10%	4%										94%	275823	

Scenario 4 : Solar Max Jun 2027	Avail	Thermal Central	Thermal State	Thermal IPP	Thermal	Nuclear	Hydro	Solar	Rooftop	Wind	RE RPO	ESS	Gas	Total avail	Demand	Surplus/Def	Net Avail	Net Dem
NR	2100	3351	0	14899	3536	17688	77688	0	6701	86235	-7500	0	103564	97170	6394	103564	97170	
WR	2040	300	3444	-14196	2592	2527	47324	0	19447	87914	-3290	0	74384	73019	1365	74384	73019	
SR	0	0	0	12571	6256	5285	62181	0	29619	70418	-16835	0	86505	72410	14096	86505	72410	
ER	994	592	1024	-3286	0	9650	938	0	0	34167	-900	0	12298	29980	-17683	12298	29980	
NER	300	0	0	-217	0	3063	85	0	0	3462	0	0	3448	3245	203	3448	3245	
Total	5433	4243	4468	9769	12384	38213	188215	0	55767	282195	-28525	0	280198	275823	4375	280198	275823	
		14145					282195								272403			

Scenario 5 : Peak Load Jun 2027	Avail	Thermal Central	Thermal State	Thermal IPP	Thermal	Nuclear	Hydro	Solar	Rooftop	Wind	Other RE	ESS	Gas	Total avail	National DF	Regional DF
NR	60%	73%	0%	101%	80%	95%	0%	0%	70%	0%	0%	50%	50%		99%	98%
WR	62%	27%	57%	24%	80%	70%	0%	0%	75%	0%	0%	50%	50%		75%	74%
SR	2%	33%	23%	27%	80%	70%	0%	0%	75%	0%	0%	50%	50%		73%	72%
ER	24%	50%	52%	40%	80%	90%	0%	0%	0%	0%	0%	50%	50%		85%	84%
NER	40%	0%	0%	158%	80%	90%	0%	0%	0%	0%	0%	50%	50%		72%	71%
Total	36%	46%	53%	45%										93%	274647	

Scenario 5 : Peak Load Jun 2027	Avail	Thermal Central	Thermal State	Thermal IPP	Thermal	Nuclear	Hydro	Solar	Rooftop	Wind	RE RPO	ESS	Gas	Total avail	Demand	Surplus/Def	Net Avail	Net Dem
NR	7115	30463	0	54182	3536	24005	0	0	9381	39821	3750	1791	80041	103080	-23039	80041	103080	
WR	11696	9282	20268	21185	2592	4422	0	0	26519	40596	1645	5069	81494	71087	10407	81494	71087	
SR	200	12198	1056	14747	6256	9248	0	0	40389	32517	8418	890	78655	62828	15827	78655	62828	
ER	6294	7208	2176	17716	0	12407	0	0	0	15777	450	0	28535	33944	-5408	28535	33944	
NER	300	0	0	1182	0	3938	0	0	0	1599	0	927	5164	3708	1457	5164	3708	
Total	25605	59150	23500	109012	12384	54021	0	0	76289	130310	14263	8678	273890	274647	-757	273890	274647	
		108255					130310								271601			

Scenario 6 : Off peak Load Jun 2027	Avail	Thermal Central	Thermal State	Thermal IPP	Thermal	Nuclear	Hydro	Solar	Rooftop	Wind	Other RE	ESS	Gas	Total avail	National DF	Regional DF
NR	41%	35%	0%	14%	80%	70%	0%	0%	60%	0%	1%	50%	50%		43%	43%
WR	29%	25%	30%	29%	80%	40%	0%	0%	65%	0%	1%	50%	50%		70%	69%
SR	2%	28%	23%	30%	80%	40%	0%	0%	65%	0%	1%	50%	50%		58%	58%
ER	17%	33%	25%	36%	80%	70%	0%	0%	0%	0%	1%	50%	50%		72%	71%
NER	40%	0%	0%	35%	80%	70%	0%	0%	0%	0%	0%	1%	50%		48%	48%
Total	22%	30%	29%	27%										65%	191555	

Scenario 6 : Off peak Load Jun 2027	Avail	Thermal Central	Thermal State	Thermal IPP	Thermal	Nuclear	Hydro	Solar	Rooftop	Wind	RE RPO	ESS	Gas	Total avail	Demand	Surplus/Def	Net Avail	Net Dem
NR	4865	14563	0	7499	3536	17688	0	0	8041	31855	75	1791	50559	44756	5803	50559	44756	
WR	5504	8703	10611	25774	2592	2527	0	0	22983	32475	33	5069	58022	65943	-7921	58022	65943	
SR	200	10315	1056	16487	6256	5285	0	0	35004	26012	168	890	59175	49813	9362	59175	49813	
ER	4258	4814	1024	15944	0	9650	0	0	0	12621	9	0	19756	28574	-8818	19756	28574	
NER	300	0	0	263	0	3063	0	0	0	1279	0	927	4289	2469	1820	4289	2469	
Total	15127	38395	12691	65967	12384	38213	0	0	66028	104241	285	8678	191801	191555	246	191801	191555	
		66213					104241								190155			

Winter (Feb'28)

Installed Capacity		Region	Thermal Central	Thermal State	Thermal IPP	Thermal	Nuclear	Hydro	Solar	Rooftop	Wind	Other RE	ESS	Gas	Total	EPS Peak Demand	App. Peak Demand	LTA
Installed Capacity	NR	11880	41838	0	53718	4420	25269	86320	4500	13401	1360	7500	3583	200070	103650	92748	0	
	WR	19000	34160	35602	88762	3240	6318	55675	4500	35359	0	3290	10139	207283	94748	84783	0	
	SR	12870	36988	4640	54498	7820	13212	73154	4500	53852	2119	16835	1781	227770	85953	76913	0	
	ER	25760	14450	4150	44360	0	13786	1103	400	0	0	900	0	60549	39847	35656	0	
	NER	750	0	0	750	0	4375	100	100	0	0	0	1854	7179	5159	4616	0	
			70260	127435	44392	242087	15480	62960	216352	14000	102612	3479	28525	17356	702851	294716	294716	
			242087			399403						329357						
Scenario 7 : Solar max Feb 2028		Availability	Thermal Central	Thermal State	Thermal IPP	Thermal	Nuclear	Hydro	Solar	Rooftop	Wind	Other RE	ESS	Gas	Total	National DF	Regional DF	
Scenario 7 : Solar max Feb 2028	NR	22%	26%	0%	23%	80%	30%	90%	0%	10%	0%	0%	-100%	0%	72%	67%		
	WR	32%	16%	37%	25%	80%	20%	90%	0%	10%	0%	0%	-100%	0%	94%	87%		
	SR	24%	45%	23%	54%	80%	20%	90%	0%	0%	0%	0%	-100%	0%	85%	79%		
	ER	24%	16%	25%	6%	80%	30%	90%	0%	0%	0%	0%	-100%	0%	70%	65%		
	NER	40%	0%	0%	19%	80%	30%	90%	0%	0%	0%	0%	-100%	0%	54%	50%		
			26%	28%	34%	27%										90%	266676	
Scenario 8 : Peak Load Feb 2028		Availability	Thermal Central	Thermal State	Thermal IPP	Thermal	Nuclear	Hydro	Solar	Rooftop	Wind	Other RE	ESS	Gas	Total	National DF	Regional DF	
Scenario 8 : Peak Load Feb 2028	NR	2628	10688	0	12113	3536	7581	77688	0	1340	66168	-7500	0	95961	74317	21644	95961	74317
	WR	6144	5556	13156	21947	2592	1264	50108	0	3536	67456	-3290	0	79065	88705	-9640	79065	88705
	SR	3108	16471	1056	29563	6256	2642	65839	0	0	54031	-16835	0	78537	73016	5521	78537	73016
	ER	6143	2376	1024	2523	0	4136	993	0	0	26216	-900	0	13771	27839	-14068	13771	27839
	NER	300	0	0	142	0	1313	90	0	0	2656	0	0	1703	2798	-1096	1703	2798
		18323	35091	15236	66289	12384	16935	194717	0	4876	216528	-28525	0	269037	266676	2362	269037	266676
			68650			216528						247350						
Scenario 9 : Off peak Load Feb 2028		Availability	Thermal Central	Thermal State	Thermal IPP	Thermal	Nuclear	Hydro	Solar	Rooftop	Wind	Other RE	ESS	Gas	Total	National DF	Regional DF	
Scenario 9 : Off peak Load Feb 2028	NR	65%	70%	0%	80%	80%	60%	0%	0%	35%	0%	0%	60%	50%	68%	65%		
	WR	69%	63%	85%	61%	80%	40%	0%	0%	20%	0%	0%	60%	50%	86%	83%		
	SR	29%	61%	66%	59%	80%	40%	0%	0%	20%	0%	0%	60%	50%	74%	71%		
	ER	46%	57%	52%	53%	80%	60%	0%	0%	0%	0%	0%	60%	50%	78%	75%		
	NER	40%	0%	0%	303%	80%	60%	0%	0%	0%	0%	0%	60%	50%	75%	73%		
			52%	64%	80%	64%										85%	249980	
Scenario 9 : Off peak Load Feb 2028		Availability	Thermal Central	Thermal State	Thermal IPP	Thermal	Nuclear	Hydro	Solar	Rooftop	Wind	Other RE	ESS	Gas	Total	National DF	Regional DF	
Scenario 9 : Off peak Load Feb 2028	NR	7709	29162	0	43037	3536	15161	0	0	4690	17236	4500	1791	66550	70100	-3550	66550	70100
	WR	13056	21362	30262	54183	2592	1264	50108	0	7072	17571	1974	5069	83914	81390	2525	83914	81390
	SR	3783	22508	3044	32333	6256	5285	0	0	10770	14074	10101	890	62638	63655	-1017	62638	63655
	ER	11937	8254	2176	23575	0	8272	0	0	0	6829	540	0	31178	30944	235	31178	30944
	NER	300	0	0	2273	0	2625	0	0	0	692	0	927	3852	3892	-40	3852	3892
		36785	81286	35482	155401	12384	33870	0	0	22533	56402	17115	8678	248132	249980	-1848	248132	249980
			153552			56402						240616						
Scenario 9 : Off peak Load Feb 2028		Availability	Thermal Central	Thermal State	Thermal IPP	Thermal	Nuclear	Hydro	Solar	Rooftop	Wind	Other RE	ESS	Gas	Total	National DF	Regional DF	
Scenario 9 : Off peak Load Feb 2028	NR	60%	36%	0%	42%	80%	30%	0%	0%	10%	0%	0%	40%	30%	37%	42%		
	WR	58%	49%	65%	48%	80%	20%	0%	0%	20%	0%	0%	40%	30%	61%	69%		
	SR	24%	42%	40%	44%	80%	20%	0%	0%	0%	0%	0%	40%	30%	51%	58%		
	ER	27%	34%	32%	37%	80%	30%	0%	0%	0%	0%	0%	40%	30%	49%	57%		
	NER	40%	0%	0%	118%	80%	30%	0%	0%	0%	0%	0%	40%	30%	34%	39%		
			41%	41%	59%	44%										55%	161005	
Scenario 9 : Off peak Load Feb 2028		Availability	Thermal Central	Thermal State	Thermal IPP	Thermal	Nuclear	Hydro	Solar	Rooftop	Wind	Other RE	ESS	Gas	Total	National DF	Regional DF	
Scenario 9 : Off peak Load Feb 2028	NR	7115	15116	0	22828	3536	7581	0	0	1340	7746	3000	1075	38762	38184	577	38762	38184
	WR	11018	16775	22984	42676	2592	1264	0	0	7072	7896	1316	3042	66062	57522	8540	66062	57522
	SR	3108	15403	1856	23984	6256	2642	0	0	0	6325	6734	534	36533	43833	-7300	36533	43833
	ER	7024	4927	1339	16283	0	4136	0	0	0	3069	360	0	17786	19712	-1926	17786	19712
	NER	300	0	0	887	0	1313	0	0	0	311	0	556	2169	1754	414	2169	1754
		28564	52220	26179	106658	12384	16935	0	0	8412	25347	11410	5207	161311	161005	306	161311	161005
			106964			25347						184249						
Scenario 9 : Off peak Load Feb 2028		Availability	Thermal Central	Thermal State	Thermal IPP	Thermal	Nuclear	Hydro	Solar	Rooftop	Wind	Other RE	ESS	Gas	Total	National DF	Regional DF	
Scenario 9 : Off peak Load Feb 2028	NR	60%	36%	0%	42%	80%	30%	0%	0%	10%	0%	0%	40%	30%	37%	42%		
	WR	58%	49%	65%	48%	80%	20%	0%	0%	20%	0%	0%	40%	30%	61%	69%		
	SR	24%	42%	40%	44%	80%	20%	0%	0%	0%	0%	0%	40%	30%	51%	58%		
	ER	27%	34%	32%	37%	80%	30%	0%	0%	0%	0%	0%	40%	30%	49%	57%		
	NER	40%	0%	0%	118%	80%	30%	0%	0%	0%	0%	0%	40%	30%	34%	39%		
			41%	41%	59%	44%										55%	161005	
			106964			25347						184249						
Scenario 9 : Off peak Load Feb 2028		Availability	Thermal Central	Thermal State	Thermal IPP	Thermal	Nuclear	Hydro	Solar	Rooftop	Wind	Other RE	ESS	Gas	Total	National DF	Regional DF	
Scenario 9 : Off peak Load Feb 2028	NR	60%	36%	0%	42%	80%	30%	0%	0%	10%	0%	0%	40%	30%	37%	42%		
	WR	58%	49%	65%	48%	80%	20%	0%	0%	20%	0%	0%	40%	30%	61%	69%		
	SR	24%	42%	40%	44%	80%	20%	0%	0%	0%	0%	0%	40%	30%	51%	58%		
	ER	27%	34%	32%	37%	80%	30%	0%	0%	0%	0%	0%	40%	30%	49%	57%		
	NER	40%	0%	0%	118%	80%	30%	0%	0%	0%	0%	0%	40%	30%	34%	39%		
			41%	41%	59%	44%										55%	161005	
			106964			25347						184249						

Page intentionally left blank.

Annex-2.2

Inter-Regional AC transmission Lines Flow

FromName	ToName	Voltage	Id	P-Sc1	P-Sc2	P-Sc3	P-Sc4	P-Sc5	P-Sc6	P-Sc7	P-Sc8	P-Sc9	Thermal Limit
MODAK	BHANPURA-2	220	1	-32	22	43	142	98	224	239	323	214	267
SAHUPU_N	PUSAULI BSPT	220	1	191	33	116	224	106	265	333	46	136	267
SALAKATI	GELEPHU1	132	1	-52	70	45	35	50	35	45	59	30	84
RAIGR2	BUDHIPADAR	220	1	109	141	162	231	145	130	186	133	154	268
SIPAT4	RNC-SIPT FSC	400	2	564	515	508	838	610	291	482	118	201	1106
SIPAT4	RNC-SIPT FSC	400	1	562	512	321	834	607	290	480	117	143	1106
BALIMELA	UPPERSILERU	220	2	-13	191	224	189	154	129	65	72	9	250

Note: Highlighted cell indicates Power flow > 70% of Thermal limit

HVDC Transmission Lines Flow

Area	From Name	To Name	Voltage	P-Sc1	P-Sc2	P-Sc3	P-Sc4	P-Sc5	P-Sc6	P-Sc7	P-Sc8	P-Sc9
IR	AGRA	BISWANATH-CH	800	250	0	0	250	0	0	250	0	0
IR	AGRA	BISWANATH-CH	800	250	0	0	250	0	0	250	0	0
IR	ALIPURDUAR	AGRA	800	0	300	300	0	300	300	0	300	300
IR	ALIPURDUAR	AGRA	800	0	300	300	0	300	300	0	300	300
NORTH	BAL74-PG	BHIWADI	1	0	500	500	0	500	500	0	500	500
NORTH	BAL74-PG	BHIWADI	1	0	500	500	0	500	500	0	500	500
NORTH	BHADLA-3 HVD	FATEH VSC	800	2999	300	300	2980	300	300	2980	300	300
NORTH	BHADLA-3 HVD	FATEH VSC	800	2999	300	300	2980	300	300	2980	300	300
IR	BHADR4	CHANDRAPR-SR	70	50	50	50	50	50	50	50	50	50
IR	BHADR4	CHANDRAPR-SR	70	50	50	50	50	50	50	50	50	50
NORTH	BHIWADI	BAL74-PG	500	1006	0	0	1000	0	0	1000	0	0
NORTH	BHIWADI	BAL74-PG	500	1006	0	0	1000	0	0	1000	0	0
NORTH	BIKANER-3	BATHINDA	800	0	0	0	0	0	0	0	0	0
NORTH	BIKANER-3	BATHINDA	800	0	0	0	0	0	0	0	0	0
IR	BISWANATH-CH	ALIPURDUAR	800	0	150	150	0	150	150	0	150	150
IR	BISWANATH-CH	ALIPURDUAR	800	0	150	150	0	150	150	0	150	150
IR	CHAMPA SPLT	KURUKSHETR	800	500	2500	2000	500	2500	2500	500	2500	2500
IR	CHAMPA_POOL	KURUKSHETR	800	500	2500	2000	500	2500	2500	500	2500	2500
IR	CHANDRAPR-SR	BHADR4	70	0	0	0	0	0	0	0	0	0
IR	CHANDRAPR-SR	BHADR4	70	0	0	0	0	0	0	0	0	0
WEST	CHANDRAPUR I	PADGH4	480	702	700	700	700	700	700	700	700	700
WEST	CHANDRAPUR I	PADGH4	480	702	700	700	700	700	700	700	700	700
NORTH	FATEHG-5	MODIPURAM(PG	800	0	0	0	0	0	0	0	0	0

Area	From Name	To Name	Voltage	P-Sc1	P-Sc2	P-Sc3	P-Sc4	P-Sc5	P-Sc6	P-Sc7	P-Sc8	P-Sc9
NORTH	FATEHG-5	MODIPURAM(PG	800	0	0	0	0	0	0	0	0	0
IR	GAZUWAKA-ER	GAZU-SR	70	327	325	325	325	325	325	325	325	325
IR	GAZUWAKA-ER	GAZU-SR	70	327	325	325	325	325	325	325	325	325
WEST	KHAVDA-II	AKOLA-III IS	800	3626	1000	1000	4000	1000	1000	4000	1000	500
WEST	KHAVDA-IIS	AKOLA-III IS	800	0	0	0	0	0	0	0	0	0
WEST	KUDUS	ARAY-220	320	1000	1000	1000	1000	1000	1000	1000	1000	1000
IR	MAHIN_HV	MUNDRA-APL	500	626	0	0	625	0	0	625	0	0
IR	MAHIN_HV	MUNDRA-APL	500	626	0	0	625	0	0	625	0	0
IR	MUNDRA-APL	MAHIN_HV	500	0	1000	1000	0	1000	1000	0	1000	500
IR	MUNDRA-APL	MAHIN_HV	500	0	1000	1000	0	1000	1000	0	1000	500
IR	PUGALUR-NEW	RAIGARH_POOL	800	1002	1500	1000	0	1500	1000	500	0	0
IR	PUGALUR-NEW	KOTRA SPLT	800	1002	1500	1000	0	1500	1000	500	0	0
SOUTH	PUGALUR-NEW	TCR-HVDC	600	1003	1000	1000	1000	1000	1000	1000	1000	1000
SOUTH	PUGALUR-NEW	TCR-HVDC	600	1003	1000	1000	1000	1000	1000	1000	1000	1000
IR	RAIGARH_POOL	PUGALUR-NEW	800	0	0	0	1000	0	0	0	3000	1500
IR	KOTRA SPLT	PUGALUR-NEW	800	0	0	0	1000	0	0	0	3000	1500
NORTH	RIHAN-HV	DADR-HVD	500	753	750	750	750	750	750	750	750	750
NORTH	RIHAN-HV	DADR-HVD	500	753	750	750	750	750	750	750	750	750
EAST	SASARAM-ER	SASARAM-NR	70	251	250	250	250	250	250	250	250	250
IR	TALCHER	KOLAR	500	501	250	400	250	500	500	250	500	500
IR	TALCHER	KOLAR	500	501	250	400	250	500	500	250	500	500
IR	VINDH_1-2-3	VINDHYBT	70	125	125	125	125	125	125	125	125	125
IR	VINDH_1-2-3	VINDHYBT	70	125	125	125	125	125	125	125	125	125

Page intentionally left blank.

Annex-2.3

765 kV Transmission Line loadings above 70% of thermal limit

Area	From Name	To Name	Id	P-Sc1	P-Sc2	P-Sc3	P-Sc4	P-Sc5	P-Sc6	P-Sc7	P-Sc8	P-Sc9	Thermal Limit
NORTH	NARELA ISTS	MERUT-PG	2	2457	305	237	2831	349	345	2220	173	201	3802
NORTH	GNOIDAUP	ALIGARH	1	-2730	1847	976	3305	2030	656	1635	362	258	3802
WEST	RAIGARH_KOTR	KOTRA SPLT	1	-1060	2394	1665	674	2584	1027	1058	1796	1555	3500
WEST	BHOPAL_STER	KURAWAR-7	1	-1888	176	685	2515	12	484	1048	518	461	3500
WEST	BOISAR-II	PUNE-III	1	-165	2540	1436	339	2872	1130	1015	981	659	3500
SOUTH	CUDP800	CUDP2_7	1	-2580	1883	1396	2706	1685	940	2315	1034	824	3500
SOUTH	CUDP800	CUDP2_7	2	-2580	1883	1396	2706	1685	940	2315	1034	824	3500
SOUTH	KURNOOL-III	MAHESHWARAM	1	2812	1758	1639	3071	1818	1433	1717	665	301	3500
SOUTH	KURNOOL-III	MAHESHWARAM	2	2812	1758	1639	3071	1818	1433	1717	665	301	3500
SOUTH	NIZAMABAD	NIZAMBD2_7	1	-2490	1706	1429	2677	1676	1077	2138	1123	562	3500
SOUTH	NIZAMABAD	NIZAMBD2_7	2	-2490	1706	1429	2677	1676	1077	2138	1123	562	3500
NORTH	NARELA ISTS	MERUT-PG	2	2457	305	237	2831	349	345	2220	173	201	3802
NORTH	GNOIDAUP	ALIGARH	1	-2730	1847	976	3305	2030	656	1635	362	258	3802
WEST	RAIGARH_KOTR	KOTRA SPLT	1	-1060	2394	1665	674	2584	1027	1058	1796	1555	3500
WEST	BHOPAL_STER	KURAWAR-7	1	-1888	176	685	2515	12	484	1048	518	461	3500
WEST	BOISAR-II	PUNE-III	1	-165	2540	1436	339	2872	1130	1015	981	659	3500
SOUTH	CUDP800	CUDP2_7	1	-2580	1883	1396	2706	1685	940	2315	1034	824	3500
SOUTH	CUDP800	CUDP2_7	2	-2580	1883	1396	2706	1685	940	2315	1034	824	3500
SOUTH	KURNOOL-III	MAHESHWARAM	1	2812	1758	1639	3071	1818	1433	1717	665	301	3500
SOUTH	KURNOOL-III	MAHESHWARAM	2	2812	1758	1639	3071	1818	1433	1717	665	301	3500
SOUTH	NIZAMABAD	NIZAMBD2_7	1	-2490	1706	1429	2677	1676	1077	2138	1123	562	3500

Area	From Name	To Name	Id	P-Sc1	P-Sc2	P-Sc3	P-Sc4	P-Sc5	P-Sc6	P-Sc7	P-Sc8	P-Sc9	Thermal Limit
SOUTH	NIZAMABAD	NIZAMBD2_7	2	-2490	1706	1429	2677	1676	1077	2138	1123	562	3500
WEST	BOISAR-II	PUNE-III	1	-165	2540	1436	339	2872	1130	1015	981	659	3500
SOUTH	CUDP800	CUDP2_7	1	-2580	1883	1396	2706	1685	940	2315	1034	824	3500
SOUTH	CUDP800	CUDP2_7	2	-2580	1883	1396	2706	1685	940	2315	1034	824	3500
SOUTH	KURNOOL-III	MAHESHWARAM	1	2812	1758	1639	3071	1818	1433	1717	665	301	3500
SOUTH	KURNOOL-III	MAHESHWARAM	2	2812	1758	1639	3071	1818	1433	1717	665	301	3500
SOUTH	NIZAMABAD	NIZAMBD2_7	1	-2490	1706	1429	2677	1676	1077	2138	1123	562	3500
SOUTH	NIZAMABAD	NIZAMBD2_7	2	-2490	1706	1429	2677	1676	1077	2138	1123	562	3500
SOUTH	NIZAMABAD	NIZAMBD2_7	2	-2490	1706	1429	2677	1676	1077	2138	1123	562	3500

Note: Highlighted cell indicates Power flow > 70% of Thermal limit

400kV Transmission Line loadings above 70% of thermal limit

Area	From Name	To Name	Id	P-Sc1	P-Sc2	P-Sc3	P-Sc4	P-Sc5	P-Sc6	P-Sc7	P-Sc8	P-Sc9	Thermal Limit
NORTH	BAGLIHAR4	NEWWANPO	1	1078	711	308	1186	701	231	925	513	314	857
NORTH	KISHENPUR	CHAMERA-2	1	805	364	288	839	380	113	361	119	174	857
NORTH	KISTAWAR	PAKALDUL	1	-904	1380	996	1001	1378	1026	438	882	451	1714
NORTH	KISTAWAR	KIRU	1	-425	606	437	439	605	450	190	386	193	857
NORTH	WANGTOO	JANGI-THOPAN	1	-510	233	167	517	233	175	425	148	74	560
NORTH	PARBT-PO	HAMIRPUR	1	580	607	396	579	582	365	377	437	271	857
NORTH	RAJPURA4	BHIWANI	1	-553	85	89	633	59	250	351	249	154	857
NORTH	MOGA SPLT4	BHIWANI-PG	1	-589	153	78	640	144	199	407	138	102	857
NORTH	MALERKOTLA4	KURUKSHETR	2	-584	494	327	600	465	220	407	268	344	857
NORTH	BHIWANI	BHIWANI-PG	1	-965	259	57	1064	278	264	606	195	194	857
NORTH	BHIWANI-PG	JINDPG	1	837	45	127	911	70	414	532	346	391	857
NORTH	BHIWANI-PG	JINDPG	2	837	45	127	911	70	414	532	346	391	857
NORTH	MERTA	JODH KANKANI	1	-660	252	199	675	213	161	567	108	73	857
NORTH	BARMER-4	RAJWEST	1	685	343	116	712	242	157	426	293	234	857
NORTH	BHADLA	BIKANE-4	1	1221	231	194	1256	195	151	1140	101	83	1714
NORTH	BHADLA	BIKANE-4	2	1221	231	194	1256	195	151	1140	101	83	1714
NORTH	BABAI	SIKAR	1	-551	80	54	617	61	175	379	180	161	857
NORTH	CHIT-NEW	JALORE	1	-671	258	173	641	230	219	638	247	123	560
NORTH	CHIT-NEW	JALORE	2	-671	258	173	641	228	219	638	247	123	560
NORTH	BASSI	KOTPUT	1	455	342	212	611	422	81	104	91	156	857
NORTH	DAUSA	AGRA	1	552	199	179	700	225	26	346	54	82	857
NORTH	DAUSA	AGRA	2	552	199	179	700	225	26	346	54	82	857
NORTH	MEJA	ALLAHABA	1	293	619	352	128	619	458	532	670	301	857

Area	From Name	To Name	Id	P-Sc1	P-Sc2	P-Sc3	P-Sc4	P-Sc5	P-Sc6	P-Sc7	P-Sc8	P-Sc9	Thermal Limit
NORTH	MEJA	ALLAHABA	2	293	619	352	128	619	458	532	670	301	857
NORTH	BAGPAT	MEERUT	1	-624	136	20	649	143	242	448	110	127	857
NORTH	BAGPAT	MEERUT	2	-624	136	20	649	143	242	448	110	127	857
NORTH	AGRAUP4	AGRA	2	-718	789	607	975	783	178	346	319	181	857
NORTH	DADR-NCR	GNOIDA4	1	612	1125	1371	673	1055	1494	746	1299	1259	1988
NORTH	LUCK4-PG	LUCK74-P	1	-911	614	619	1269	535	524	1028	521	457	1714
NORTH	LUCK4-PG	LUCK74-P	2	-911	614	619	1269	535	524	1028	521	457	1714
NORTH	LUCK74-P	KANPRNEW	1	-555	305	277	670	352	169	572	185	159	857
NORTH	LUCK74-P	KANPRNEW	2	-555	305	277	670	352	169	572	185	159	857
NORTH	ANPARA4	SINGRL4	1	-213	333	419	304	342	117	266	352	853	857
NORTH	KHURJA TPS	ALIGARH	1	594	298	251	731	338	58	404	78	45	857
NORTH	SIDCL HARDWR	ROORKEE	1	367	470	320	410	471	147	153	226	85	560
NORTH	SIDCL HARDWR	RISHIKE4_PT	1	-499	578	371	540	589	139	284	342	158	560
IR	SIPAT4	RNC-SIPT FSC	2	564	515	508	838	610	291	482	118	201	1106
IR	SIPAT4	RNC-SIPT FSC	1	562	512	321	834	607	290	480	117	143	1106
WEST	CHORN4	KASOR4	1	508	53	76	613	59	64	553	47	30	857
WEST	BACHAU	HALVAD NEW	1	910	844	553	716	862	559	666	290	347	1283
WEST	SATPURA	KORADI-I	1	644	125	170	479	96	417	538	25	92	857
WEST	KARAD4	JEJ4	3	414	654	514	453	680	507	203	319	135	857
WEST	DHULE4	BABLESWAR	2	624	317	228	532	257	376	647	376	359	857
EAST	PURNEA-NW-PG	SILIGURI-PG	1	-564	624	555	513	775	649	67	332	157	1093
EAST	PURNEA-NW-PG	SILIGURI-PG	2	-564	624	555	513	775	649	67	332	157	1093
EAST	ANGUL-A	ANGUL-BYPAS2	@1	317	378	318	344	319	284	394	358	290	0
EAST	OPGC-ISTS	OPGC-OD	@1	854	696	696	995	682	585	879	616	582	0
EAST	RANCHI	RNC-SIPT FSC	2	-541	495	493	796	583	310	469	201	238	850

Area	From Name	To Name	Id	P-Sc1	P-Sc2	P-Sc3	P-Sc4	P-Sc5	P-Sc6	P-Sc7	P-Sc8	P-Sc9	Thermal Limit
EAST	RANCHI	RNC-SIPT FSC	1	-539	493	316	793	580	309	468	201	153	850
SOUTH	VIJW	VIJTP-IV	1	-522	211	195	649	193	153	812	420	278	850
SOUTH	CUDP	CHITOR	1	1101	604	333	1021	442	220	985	103	116	852
SOUTH	CUDP	ANANTPUR	1	-1841	561	406	1941	502	354	1638	269	153	2186
SOUTH	CUDP	ANANTPUR	2	-1841	561	406	1941	502	354	1638	269	153	2186
SOUTH	CUDP	FSC-3	1	661	256	343	728	304	337	353	120	116	850
SOUTH	CUDP	FSC-4	2	661	256	343	728	304	337	353	120	116	850
SOUTH	KURNOOL4	SSLBPH4	1	1161	287	390	1220	322	397	654	206	150	850
SOUTH	HYDERABAD	MAHESWRM	1	-1645	749	824	1689	820	734	988	205	158	850
SOUTH	SMNH	BIDADI	1	-540	405	221	486	331	185	608	93	128	850
SOUTH	SMNH	BIDADI	2	-540	405	221	486	331	185	608	93	128	850
SOUTH	SPBUDUR4	SVCHTRM	1	461	542	163	365	355	189	727	381	227	852
SOUTH	MALEKT	TIRUVLM SE-A	1	-696	551	340	690	438	307	666	458	236	850
SOUTH	MALEKT	TIRUVLM SE-A	2	-696	551	340	690	438	307	666	458	236	850
NORTH	BAGLIHAR4	NEWWANPO	1	1078	711	308	1186	701	231	925	513	314	857
NORTH	KISHENPUR	CHAMERA-2	1	805	364	288	839	380	113	361	119	174	857
NORTH	KISTAWAR	PAKALDUL	1	-904	1380	996	1001	1378	1026	438	882	451	1714
NORTH	KISTAWAR	KIRU	1	-425	606	437	439	605	450	190	386	193	857
NORTH	WANGTOO	JANGI-THOPAN	1	-510	233	167	517	233	175	425	148	74	560
NORTH	PARBT-PO	HAMIRPUR	1	580	607	396	579	582	365	377	437	271	857
NORTH	RAJPURA4	BHIWANI	1	-553	85	89	633	59	250	351	249	154	857
NORTH	MOGA SPLT4	BHIWANI-PG	1	-589	153	78	640	144	199	407	138	102	857
NORTH	MALERKOTLA4	KURUKSHETR	2	-584	494	327	600	465	220	407	268	344	857
NORTH	BHIWANI	BHIWANI-PG	1	-965	259	57	1064	278	264	606	195	194	857
NORTH	BHIWANI-PG	JINDPG	1	837	45	127	911	70	414	532	346	391	857

Area	From Name	To Name	Id	P-Sc1	P-Sc2	P-Sc3	P-Sc4	P-Sc5	P-Sc6	P-Sc7	P-Sc8	P-Sc9	Thermal Limit
NORTH	BHIWANI-PG	JINDPG	2	837	45	127	911	70	414	532	346	391	857
NORTH	MERTA	JODH KANKANI	1	-660	252	199	675	213	161	567	108	73	857
NORTH	BARMER-4	RAJWEST	1	685	343	116	712	242	157	426	293	234	857
NORTH	BHADLA	BIKANE-4	1	1221	231	194	1256	195	151	1140	101	83	1714
NORTH	BHADLA	BIKANE-4	2	1221	231	194	1256	195	151	1140	101	83	1714
NORTH	BABAI	SIKAR	1	-551	80	54	617	61	175	379	180	161	857
NORTH	CHIT-NEW	JALORE	1	-671	258	173	641	230	219	638	247	123	560
NORTH	CHIT-NEW	JALORE	2	-671	258	173	641	228	219	638	247	123	560
NORTH	BASSI	KOTPUT	1	455	342	212	611	422	81	104	91	156	857
NORTH	DAUSA	AGRA	1	552	199	179	700	225	26	346	54	82	857
NORTH	DAUSA	AGRA	2	552	199	179	700	225	26	346	54	82	857
NORTH	MEJA	ALLAHABA	1	293	619	352	128	619	458	532	670	301	857
NORTH	MEJA	ALLAHABA	2	293	619	352	128	619	458	532	670	301	857
NORTH	BAGPAT	MEERUT	1	-624	136	20	649	143	242	448	110	127	857
NORTH	BAGPAT	MEERUT	2	-624	136	20	649	143	242	448	110	127	857
NORTH	AGRAUP4	AGRA	2	-718	789	607	975	783	178	346	319	181	857
NORTH	DADR-NCR	GNOIDA4	1	612	1125	1371	673	1055	1494	746	1299	1259	1988
NORTH	LUCK4-PG	LUCK74-P	1	-911	614	619	1269	535	524	1028	521	457	1714
NORTH	LUCK4-PG	LUCK74-P	2	-911	614	619	1269	535	524	1028	521	457	1714
NORTH	LUCK74-P	KANPRNEW	1	-555	305	277	670	352	169	572	185	159	857
NORTH	LUCK74-P	KANPRNEW	2	-555	305	277	670	352	169	572	185	159	857
NORTH	ANPARA4	SINGRL4	1	-213	333	419	304	342	117	266	352	853	857
NORTH	KHURJA TPS	ALIGARH	1	594	298	251	731	338	58	404	78	45	857
NORTH	SIDCL HARDWR	ROORKEE	1	367	470	320	410	471	147	153	226	85	560
NORTH	SIDCL HARDWR	RISHIKE4_PT	1	-499	578	371	540	589	139	284	342	158	560

Area	From Name	To Name	Id	P-Sc1	P-Sc2	P-Sc3	P-Sc4	P-Sc5	P-Sc6	P-Sc7	P-Sc8	P-Sc9	Thermal Limit
IR	SIPAT4	RNC-SIPT FSC	2	564	515	508	838	610	291	482	118	201	1106
IR	SIPAT4	RNC-SIPT FSC	1	562	512	321	834	607	290	480	117	143	1106
WEST	CHORN4	KASOR4	1	508	53	76	613	59	64	553	47	30	857
WEST	BACHAU	HALVAD NEW	1	910	844	553	716	862	559	666	290	347	1283
WEST	SATPURA	KORADI-I	1	644	125	170	479	96	417	538	25	92	857
WEST	KARAD4	JEJ4	3	414	654	514	453	680	507	203	319	135	857
WEST	DHULE4	BABLESWAR	2	624	317	228	532	257	376	647	376	359	857
EAST	PURNEA-NW-PG	SILIGURI-PG	1	-564	624	555	513	775	649	67	332	157	1093
EAST	PURNEA-NW-PG	SILIGURI-PG	2	-564	624	555	513	775	649	67	332	157	1093
EAST	ANGUL-A	ANGUL-BYPAS2	@1	317	378	318	344	319	284	394	358	290	0
EAST	OPGC-ISTS	OPGC-OD	@1	854	696	696	995	682	585	879	616	582	0
EAST	RANCHI	RNC-SIPT FSC	2	-541	495	493	796	583	310	469	201	238	850
EAST	RANCHI	RNC-SIPT FSC	1	-539	493	316	793	580	309	468	201	153	850
SOUTH	VIJW	VIJTP-IV	1	-522	211	195	649	193	153	812	420	278	850
SOUTH	CUDP	CHITOR	1	1101	604	333	1021	442	220	985	103	116	852
SOUTH	CUDP	ANANTPUR	1	-1841	561	406	1941	502	354	1638	269	153	2186
SOUTH	CUDP	ANANTPUR	2	-1841	561	406	1941	502	354	1638	269	153	2186
SOUTH	CUDP	FSC-3	1	661	256	343	728	304	337	353	120	116	850
SOUTH	CUDP	FSC-4	2	661	256	343	728	304	337	353	120	116	850
SOUTH	KURNOOL4	SSLBPH4	1	1161	287	390	1220	322	397	654	206	150	850
SOUTH	HYDERABAD	MAHESWRM	1	-1645	749	824	1689	820	734	988	205	158	850
SOUTH	SMNH	BIDADI	1	-540	405	221	486	331	185	608	93	128	850
SOUTH	SMNH	BIDADI	2	-540	405	221	486	331	185	608	93	128	850
SOUTH	SPBUDUR4	SVCHTRM	1	461	542	163	365	355	189	727	381	227	852
SOUTH	MALEKTT	TIRUVLM SE-A	1	-696	551	340	690	438	307	666	458	236	850

Area	From Name	To Name	Id	P-Sc1	P-Sc2	P-Sc3	P-Sc4	P-Sc5	P-Sc6	P-Sc7	P-Sc8	P-Sc9	Thermal Limit
SOUTH	MALEKTT	TIRUVLM SE-A	2	-696	551	340	690	438	307	666	458	236	850

Note: Highlighted cell indicates Power flow > 70% of Thermal limit

Annex-2.4

765/400 kV ICT loadings above 80% of MVA rating

Area	From Name	Voltage	To Name	Voltage	Id	P-Sc1	P-Sc2	P-Sc3	P-Sc4	P-Sc5	P-Sc6	P-Sc7	P-Sc8	P-Sc9	MVA Rating
NORTH	BHIWANI-PG	400	BHIWN-PG	765	1	-1049	-251	-20	-1110	-293	329	-691	250	294	1000
NORTH	BHIWANI-PG	400	BHIWN-PG	765	2	-1049	-251	-20	-1110	-293	329	-691	250	294	1000
NORTH	BHIWANI-PG	400	BHIWN-PG	765	3	-1573	-251	-20	-1665	-293	329	-1036	250	294	1500
NORTH	BHIWANI SR	400	BHIWN-PG	765	2	-933	-126	35	-994	-179	287	-649	238	244	1000
NORTH	BHADLA-2	400	BHADLA-2	765	1	1211	40	37	1241	34	39	1191	-7	-14	1500
NORTH	BHADLA-2	400	BHADLA-2	765	2	1211	40	37	1241	34	39	1191	-7	-14	1500
NORTH	BHADLA-2	400	BHADLA-2	765	3	1211	40	37	1241	34	39	1191	-7	-14	1500
NORTH	BHADLA-2	400	BHADLA-2	765	4	1211	40	37	1241	34	39	1191	-7	-14	1500
NORTH	BHADLA-2	400	BHADLA-2	765	5	1211	40	37	1241	34	39	1191	-7	-14	1500
NORTH	BIKANER-3	400	BIKANER-3	765	1	1117	247	188	1206	244	64	1084	140	72	1500
NORTH	BIKANER-3	400	BIKANER-3	765	2	1117	247	188	1206	244	64	1084	140	72	1500
NORTH	BIKANER-3	400	BIKANER-3	765	3	1117	247	188	1206	244	64	1084	140	72	1500
NORTH	BIKANER-3	400	BIKANER-3	765	4	1117	247	188	1206	244	64	1084	140	72	1500
NORTH	BIKANER-3	400	BIKANER-3	765	5	1117	247	188	1206	244	64	1084	140	72	1500
NORTH	BARMER1_4	400	BARMER1	765	1	835	312	249	836	267	280	774	252	128	0
NORTH	BARMER1_4	400	BARMER1	765	2	835	312	249	836	267	280	774	252	128	0
NORTH	BARMER1_4	400	BARMER1	765	3	835	312	249	836	267	280	774	252	128	0
NORTH	BARMER1_4	400	BARMER1	765	4	835	312	249	836	267	280	774	252	128	0
WEST	SIPAT4	400	SIPAT	765	1	-673	-509	-438	-815	-554	-336	-574	-183	-150	1000
WEST	SIPAT4	400	SIPAT	765	2	-673	-509	-438	-815	-554	-336	-574	-183	-150	1000

Area	From Name	Voltage	To Name	Voltage	Id	P-Sc1	P-Sc2	P-Sc3	P-Sc4	P-Sc5	P-Sc6	P-Sc7	P-Sc8	P-Sc9	MVA Rating
WEST	INDORE-74	400	INDORE-7	765	2	-928	-469	-345	- 1053	-411	-541	- 1414	-492	-162	1500
SOUTH	KURNOOL-III	400	KURNOOL-III	765	1	1272	495	449	1331	514	481	857	94	-51	1500
SOUTH	KURNOOL-III	400	KURNOOL-III	765	2	1272	495	449	1331	514	481	857	94	-51	1500
SOUTH	KURNOOL-III	400	KURNOOL-III	765	3	1272	495	449	1331	514	481	857	94	-51	1500
SOUTH	KURNOOL-III	400	KURNOOL-III	765	4	1272	495	449	1331	514	481	857	94	-51	1500
SOUTH	KURNOOL-III	400	KURNOOL-III	765	5	1272	495	449	1331	514	481	857	94	-51	1500
SOUTH	KURNOOL-III	400	KURNOOL-III	765	6	1272	495	449	1331	514	481	857	94	-51	1500
SOUTH	ANANTPR2_4	400	ANANTPR2_7	765	1	4414	4460	3579	4668	4261	2882	2684	2080	796	7500
SOUTH	KURN4_4	400	KURN4_7	765	1	4075	4237	3270	4405	3938	2176	3090	2459	1194	7500
SOUTH	CUDP2_4	400	CUDP2_7	765	1	1792	891	586	1996	742	15	2247	899	597	4500
SOUTH	NIZAMABAD	400	NIZAMABAD	765	1	- 1257	-580	-642	- 1125	-618	-596	-981	-442	-503	1500
SOUTH	NIZAMABAD	400	NIZAMABAD	765	2	- 1257	-580	-642	- 1125	-618	-596	-981	-442	-503	1500
SOUTH	NIZAMABAD	400	NIZAMABAD	765	3	- 1257	-580	-642	- 1125	-618	-596	-981	-442	-503	1500
SOUTH	NIZAMABAD	400	NIZAMABAD	765	4	- 1257	-580	-642	- 1125	-618	-596	-981	-442	-503	1500
SOUTH	MAHESWRM	400	MAHESHWARAM	765	1	- 1349	-740	-655	- 1292	-678	-585	- 1069	-426	-389	9000
SOUTH	MAHESWRM	400	MAHESHWARAM	765	2	- 1349	-740	-655	- 1292	-678	-585	- 1069	-426	-389	1500
SOUTH	MAHESWRM	400	MAHESHWARAM	765	3	- 1349	-740	-655	- 1292	-678	-585	- 1069	-426	-389	1500

- Note: Highlighted cell indicates Power flow > 80% of MVA rating

400/220 kV ICT loadings above 80% of MVA rating

Area	From Name	Voltage	To Name	Voltage	Id	P-Sc1	P-Sc2	P-Sc3	P-Sc4	P-Sc5	P-Sc6	P-Sc7	P-Sc8	P-Sc9	MVA Rating
NORTH	KISHENPUR	220	KISHENPUR	400	1	-518	-340	-167	-552	-334	-96	-418	-216	-132	315
NORTH	KISHENPUR	220	KISHENPUR	400	2	-518	-340	-167	-552	-334	-96	-418	-216	-132	315
NORTH	KISHENPUR	220	KISHENPUR	400	3	-518	-340	-167	-552	-334	-96	-418	-216	-132	315
NORTH	PANG220SP2	220	PANG400SP2	400	1	262	0	0	269	0	0	271	0	0	315
NORTH	PANG220SP2	220	PANG400SP2	400	2	262	0	0	269	0	0	271	0	0	315
NORTH	PANG220SP2	220	PANG400SP2	400	3	262	0	0	269	0	0	271	0	0	315
NORTH	PANG220SP2	220	PANG400SP2	400	4	262	0	0	269	0	0	271	0	0	315
NORTH	PANG220SP2	220	PANG400SP2	400	5	262	0	0	269	0	0	271	0	0	315
NORTH	PANG220SP2	220	PANG400SP2	400	6	262	0	0	269	0	0	271	0	0	315
NORTH	PANG220SP3	220	PANG400SP3	400	1	262	0	0	269	0	0	271	0	0	315
NORTH	PANG220SP3	220	PANG400SP3	400	2	262	0	0	269	0	0	271	0	0	315
NORTH	PANG220SP3	220	PANG400SP3	400	3	262	0	0	269	0	0	271	0	0	315
NORTH	PANG220SP3	220	PANG400SP3	400	4	262	0	0	269	0	0	271	0	0	315
NORTH	PANG220SP3	220	PANG400SP3	400	5	262	0	0	269	0	0	271	0	0	315
NORTH	PANG220SP3	220	PANG400SP3	400	6	262	0	0	269	0	0	271	0	0	315
NORTH	PATRAN42	220	PATRAN4	400	1	-410	-211	-132	-421	-199	-37	-232	-19	-28	500
NORTH	PATRAN42	220	PATRAN4	400	2	-410	-211	-132	-421	-199	-37	-232	-19	-28	500
NORTH	PATRAN42	220	PATRAN4	400	3	-410	-211	-132	-421	-199	-37	-232	-19	-28	500
NORTH	DEEDWANA-42	220	DEEDWANA	400	1	-245	-175	-123	-263	-195	-70	-233	-135	-65	315
NORTH	DEEDWANA-42	220	DEEDWANA	400	2	-245	-175	-123	-263	-195	-70	-233	-135	-65	315
NORTH	HINDAU-4	220	HINDAU-4	400	1	-233	-217	-145	-242	-242	-108	-254	-217	-112	315
NORTH	HINDAU-4	220	HINDAU-4	400	2	-233	-217	-145	-242	-242	-108	-254	-217	-112	315
NORTH	HIRAPURA	220	HERAPU-4	400	1	-283	-229	-155	-296	-256	-103	-291	-204	-104	315
NORTH	HIRAPURA	220	HERAPU-4	400	2	-225	-182	-123	-235	-203	-82	-231	-162	-83	250

Area	From Name	Voltage	To Name	Voltage	Id	P-Sc1	P-Sc2	P-Sc3	P-Sc4	P-Sc5	P-Sc6	P-Sc7	P-Sc8	P-Sc9	MVA Rating
NORTH	HIRAPURA	220	HERAPU-4	400	3	-225	-182	-123	-235	-203	-82	-231	-162	-83	250
NORTH	HIRAPURA	220	HERAPU-4	400	4	-225	-182	-123	-235	-203	-82	-231	-162	-83	250
NORTH	CHITTOR-42	220	CHITTOR4	400	1	-270	-211	-135	-303	-245	-49	-306	-187	-89	315
NORTH	CHITTOR-42	220	CHITTOR4	400	2	-270	-211	-135	-303	-245	-49	-306	-187	-89	315
NORTH	CHITTOR-42	220	CHITTOR4	400	3	-270	-211	-135	-303	-245	-49	-306	-187	-89	315
NORTH	BASSI	220	BASSI	400	1	-245	-187	-129	-257	-210	-85	-249	-161	-85	315
NORTH	BASSI	220	BASSI	400	2	-245	-187	-129	-257	-210	-85	-249	-161	-85	315
NORTH	BASSI	220	BASSI	400	3	-389	-297	-204	-408	-333	-135	-396	-256	-135	500
NORTH	BHADLA-S	220	BHADLA	400	1	427	-64	-40	444	-81	-39	360	-127	-81	500
NORTH	BHADLA-S	220	BHADLA	400	2	427	-64	-40	444	-81	-39	360	-127	-81	500
NORTH	BHADLA-S	220	BHADLA	400	3	427	-64	-40	444	-81	-39	360	-127	-81	500
NORTH	BHADLA-S	220	BHADLA	400	4	427	-64	-40	444	-81	-39	360	-127	-81	500
NORTH	KALISIND	220	KALISI-4	400	2	-212	-367	-213	-171	-354	-258	-377	-530	-282	500
NORTH	AJMER42	220	AJMER	400	1	-216	-236	-158	-227	-262	-102	-249	-226	-121	315
NORTH	AJMER42	220	AJMER	400	2	-216	-236	-158	-227	-262	-102	-249	-226	-121	315
NORTH	BHIWADI	220	BHIWADI	400	1	-184	-242	-177	-196	-263	-133	-165	-196	-121	315
NORTH	BHIWADI	220	BHIWADI	400	2	-185	-242	-177	-196	-264	-133	-165	-196	-121	315
NORTH	BHIWADI	220	BHIWADI	400	3	-185	-242	-177	-196	-264	-133	-165	-196	-121	315
NORTH	JODHPURN-42	220	JODH KANKANI	400	1	-91	-237	-154	-88	-272	-127	-146	-292	-171	315
NORTH	BHADLA-PG	220	BHADLA PG	400	1	442	0	0	454	0	0	459	0	0	500
NORTH	BHADLA-PG	220	BHADLA PG	400	2	442	0	0	454	0	0	459	0	0	500
NORTH	BHADLA-PG	220	BHADLA PG	400	3	442	0	0	454	0	0	459	0	0	500
NORTH	BHADLA-PG	220	BHADLA PG	400	4	442	0	0	454	0	0	459	0	0	500
NORTH	BHADLA-PG	220	BHADLA PG	400	5	442	0	0	454	0	0	459	0	0	500
NORTH	BHADLA-PG	220	BHADLA PG	400	6	442	0	0	454	0	0	459	0	0	500
NORTH	RAMGARH-I	220	RAMG-I	400	1	424	0	0	435	0	0	439	0	0	500

Area	From Name	Voltage	To Name	Voltage	Id	P-Sc1	P-Sc2	P-Sc3	P-Sc4	P-Sc5	P-Sc6	P-Sc7	P-Sc8	P-Sc9	MVA Rating
NORTH	RAMGARH-I	220	RAMG-I	400	2	424	0	0	435	0	0	439	0	0	500
NORTH	FATEH-2	220	FATEHG-2	400	1	391	0	0	380	0	0	405	0	0	500
NORTH	FATEH-2	220	FATEHG-2	400	2	391	0	0	380	0	0	405	0	0	500
NORTH	FATEH-2	220	FATEHG-2	400	3	391	0	0	380	0	0	405	0	0	500
NORTH	FATEH-2	220	FATEHG-2	400	4	391	0	0	380	0	0	405	0	0	500
NORTH	FATEH-2	220	FATEHG-2	400	5	391	0	0	380	0	0	405	0	0	500
NORTH	FATEH-2	220	FATEHG-2	400	6	391	0	0	380	0	0	405	0	0	500
NORTH	FATEHG-3	220	FATEHG-3	400	1	456	0	0	456	0	0	473	0	0	500
NORTH	FATEHG-3	220	FATEHG-3	400	2	456	0	0	456	0	0	473	0	0	500
NORTH	FATEHG-3	220	FATEHG-3	400	3	456	0	0	456	0	0	473	0	0	500
NORTH	FATEHG-3	220	FATEHG-3	400	4	456	0	0	456	0	0	473	0	0	500
NORTH	FATEHG-3	220	FATEHG-3	400	5	456	0	0	456	0	0	473	0	0	500
NORTH	FATEHG-4	220	FATEHG-4	400	1	395	0	0	406	0	0	410	0	0	500
NORTH	FATEHG-4	220	FATEHG-4	400	2	395	0	0	406	0	0	410	0	0	500
NORTH	FATEHG-4	220	FATEHG-4	400	3	395	0	0	406	0	0	410	0	0	500
NORTH	FATEHG-4	220	FATEHG-4	400	4	395	0	0	406	0	0	410	0	0	500
NORTH	FATEHG-4	220	FATEHG-4	400	5	395	0	0	406	0	0	410	0	0	500
NORTH	BHADLA-3	220	BHADLA-3	400	1	424	0	0	435	0	0	439	0	0	500
NORTH	BHADLA-3	220	BHADLA-3	400	2	424	0	0	435	0	0	439	0	0	1500
NORTH	BHADLA-3	220	BHADLA-3	400	3	424	0	0	435	0	0	439	0	0	500
NORTH	BHADLA-3	220	BHADLA-3	400	4	424	0	0	435	0	0	439	0	0	500
NORTH	BHADLA-3	220	BHADLA-3	400	5	424	0	0	435	0	0	439	0	0	500
NORTH	BIKANER-2	220	BIKANER-II	400	1	420	0	0	432	0	0	436	0	0	500
NORTH	BIKANER-2	220	BIKANER-II	400	10	420	0	0	432	0	0	436	0	0	500
NORTH	BIKANER-2	220	BIKANER-II	400	2	420	0	0	432	0	0	436	0	0	500
NORTH	BIKANER-2	220	BIKANER-II	400	3	420	0	0	432	0	0	436	0	0	500

Area	From Name	Voltage	To Name	Voltage	Id	P-Sc1	P-Sc2	P-Sc3	P-Sc4	P-Sc5	P-Sc6	P-Sc7	P-Sc8	P-Sc9	MVA Rating
NORTH	BIKANER-2	220	BIKANER-II	400	4	420	0	0	432	0	0	436	0	0	500
NORTH	BIKANER-2	220	BIKANER-II	400	5	420	0	0	432	0	0	436	0	0	500
NORTH	BIKANER-2	220	BIKANER-II	400	6	420	0	0	432	0	0	436	0	0	500
NORTH	BIKANER-2	220	BIKANER-II	400	7	420	0	0	432	0	0	436	0	0	500
NORTH	BIKANER-2	220	BIKANER-II	400	8	420	0	0	432	0	0	436	0	0	500
NORTH	BIKANER-2	220	BIKANER-II	400	9	420	0	0	432	0	0	436	0	0	500
NORTH	BHADLA-2	220	BHADLA-2	400	1	458	0	0	470	0	0	475	0	0	500
NORTH	BHADLA-2	220	BHADLA-2	400	2	458	0	0	470	0	0	475	0	0	500
NORTH	BHADLA-2	220	BHADLA-2	400	3	458	0	0	470	0	0	475	0	0	500
NORTH	BHADLA-2	220	BHADLA-2	400	4	458	0	0	470	0	0	475	0	0	500
NORTH	BHADLA-2	220	BHADLA-2	400	5	458	0	0	470	0	0	475	0	0	500
NORTH	BHAD-2 SPLT	220	BHADLA-2	400	1	446	0	0	458	0	0	462	0	0	500
NORTH	BHAD-2 SPLT	220	BHADLA-2	400	2	446	0	0	458	0	0	462	0	0	500
NORTH	BHAD-2 SPLT	220	BHADLA-2	400	3	446	0	0	458	0	0	462	0	0	500
NORTH	KOTA	220	KOTA	400	1	-284	-237	-162	-290	-245	-108	-343	-240	-138	315
NORTH	KOTA	220	KOTA	400	2	-284	-237	-162	-290	-245	-108	-343	-240	-138	315
NORTH	FATEH-SPL 2	220	FATEHG-2	400	1	388	0	0	398	0	0	402	0	0	500
NORTH	FATEH-SPL 2	220	FATEHG-2	400	2	388	0	0	398	0	0	402	0	0	500
NORTH	FATEH-SPL 2	220	FATEHG-2	400	3	388	0	0	398	0	0	402	0	0	500
NORTH	FATEH-SPL 2	220	FATEHG-2	400	4	388	0	0	398	0	0	402	0	0	500
NORTH	FATEH-SPL 2	220	FATEHG-2	400	5	388	0	0	398	0	0	402	0	0	500
NORTH	FATEH-SPL 2	220	FATEHG-2	400	6	388	0	0	398	0	0	402	0	0	500
NORTH	BHADLA3-SPL	220	BHADLA-3	400	1	424	0	0	435	0	0	439	0	0	500
NORTH	BHADLA3-SPL	220	BHADLA-3	400	2	424	0	0	435	0	0	439	0	0	500
NORTH	BHADLA3-SPL	220	BHADLA-3	400	3	424	0	0	435	0	0	439	0	0	500
NORTH	BHADLA3-SPL	220	BHADLA-3	400	4	424	0	0	435	0	0	439	0	0	500

Area	From Name	Voltage	To Name	Voltage	Id	P-Sc1	P-Sc2	P-Sc3	P-Sc4	P-Sc5	P-Sc6	P-Sc7	P-Sc8	P-Sc9	MVA Rating
NORTH	BHADLA3-SPL	220	BHADLA-3	400	5	424	0	0	435	0	0	439	0	0	500
NORTH	OBRA2	220	OBRA4	400	1	-155	-251	-165	-143	-259	-137	-169	-240	-145	315
NORTH	OBRA2	220	OBRA4	400	2	-155	-251	-165	-143	-259	-137	-169	-240	-145	315
NORTH	OBRA2	220	OBRA4	400	3	-118	-191	-126	-109	-197	-105	-129	-183	-110	240
NORTH	ALIGARH	220	ALIGARH	400	1	-326	-367	-246	-352	-404	-126	-255	-271	-130	500
NORTH	ALIGARH	220	ALIGARH	400	2	-326	-367	-246	-352	-404	-126	-255	-271	-130	500
NORTH	ALLAHABA	220	ALLAHABA	400	1	-204	-264	-186	-223	-282	-109	-170	-207	-123	315
NORTH	ALLAHABA	220	ALLAHABA	400	2	-204	-264	-186	-223	-282	-109	-170	-207	-123	315
NORTH	ALLAHABA	220	ALLAHABA	400	3	-204	-264	-186	-223	-282	-109	-170	-207	-123	315
NORTH	KANPU-PG	220	KANPUR	400	1	-257	-196	-156	-300	-218	-69	-201	-116	-57	315
NORTH	KANPU-PG	220	KANPUR	400	2	-257	-196	-156	-300	-218	-69	-201	-116	-57	315
NORTH	REWAROAD	220	REWA	400	1	-245	-322	-213	-241	-340	-161	-236	-277	-145	315
WEST	KORBA-WEST	220	KORBA-WEST	400	1	-278	-405	-259	-257	-389	-224	-195	-233	-172	500
WEST	MUNDRA-APL	220	MUNDRA-APL	400	1	43	296	265	66	275	262	-59	124	93	315
WEST	MUNDRA-APL	220	MUNDRA-APL	400	2	43	296	265	66	275	262	-59	124	93	315
WEST	DATIYA NEW2	220	DATIYA NEW4	400	1	-331	-141	-87	-305	-118	-157	-470	-249	-154	500
WEST	DATIYA NEW2	220	DATIYA NEW4	400	2	-331	-141	-87	-305	-118	-157	-470	-249	-154	500
WEST	WARDH_PG	220	WARDHA SPLT	400	2	-271	-169	-116	-231	-171	-158	-261	-82	-44	315
WEST	WARDH_PG	220	WARDHA SPLT	400	3	-271	-169	-116	-231	-171	-158	-261	-82	-44	315
WEST	WARDH_PG	220	WARDHA SPLT	400	4	-434	-269	-186	-372	-273	-253	-417	-130	-69	500
WEST	KHARGR22	220	KHARGAR	400	1	-239	-179	-95	-207	-150	-153	-259	-189	-135	315
WEST	KHARGR22	220	KHARGAR	400	2	-239	-179	-95	-207	-150	-153	-259	-189	-135	315
WEST	KHARGR22	220	KHARGAR	400	3	-380	-284	-150	-330	-239	-243	-412	-302	-214	500
WEST	NAGOTHA2	220	NAGOTHANE	400	1	-258	-116	-162	-249	-107	-110	-201	-119	-120	315
WEST	NAGOTHA2	220	NAGOTHANE	400	2	-409	-183	-256	-395	-170	-174	-319	-189	-190	500
WEST	NAGOTHA2	220	NAGOTHANE	400	3	-258	-116	-162	-249	-107	-110	-201	-119	-120	315

Area	From Name	Voltage	To Name	Voltage	Id	P-Sc1	P-Sc2	P-Sc3	P-Sc4	P-Sc5	P-Sc6	P-Sc7	P-Sc8	P-Sc9	MVA Rating
WEST	NAVI-MUM220	220	NAVI-MUM	400	1	-250	-179	-103	-221	-151	-156	-269	-192	-144	315
WEST	NAVI-MUM220	220	NAVI-MUM	400	2	-250	-179	-103	-221	-151	-156	-269	-192	-144	315
WEST	VIKROLI220	220	VIKROLI400	400	1	-382	-321	-166	-328	-276	-272	-409	-321	-210	500
WEST	VIKROLI220	220	VIKROLI400	400	2	-382	-321	-166	-328	-276	-272	-409	-321	-210	500
WEST	VIKROLI220	220	VIKROLI400	400	3	-382	-321	-166	-328	-276	-272	-409	-321	-210	500
WEST	KALLAM	220	KALLAM	400	1	282	443	392	285	443	382	52	119	119	500
WEST	KALLAM	220	KALLAM	400	2	282	443	392	285	443	382	52	119	119	500
WEST	KALLAM	220	KALLAM	400	3	282	443	392	285	443	382	52	119	119	500
WEST	KALLAM	220	KALLAM	400	4	282	443	392	285	443	382	52	119	119	500
EAST	DUBRI NEW	220	DUBURI	400	1	-247	-290	-253	-272	-259	-224	-269	-262	-240	315
EAST	DUBRI NEW	220	DUBURI	400	2	-247	-290	-253	-272	-259	-224	-269	-262	-240	315
EAST	MENDHASAL	220	MENDHASAL	400	1	-163	-242	-168	-153	-192	-159	-211	-255	-165	315
EAST	MENDHASAL	220	MENDHASAL	400	2	-163	-242	-168	-153	-192	-159	-211	-255	-165	315
EAST	MENDHASAL	220	MENDHASAL	400	3	-163	-242	-168	-153	-192	-159	-211	-255	-165	315
EAST	LAPANGA2	220	LAPANGA	400	1	-203	-214	-169	-201	-163	-156	-262	-249	-167	315
EAST	LAPANGA2	220	LAPANGA	400	2	-203	-214	-169	-201	-163	-156	-262	-249	-167	315
EAST	KTPS220	220	KOLAGHAT	400	1	-272	-339	-255	-288	-303	-207	-224	-208	-119	315
EAST	KTPS220	220	KOLAGHAT	400	2	-272	-339	-255	-288	-303	-207	-224	-208	-119	315
EAST	CHANDITALA_N	220	CHANDITALA_N	400	1	-272	-327	-251	-285	-295	-215	-224	-207	-123	315
EAST	CHANDITALA_N	220	CHANDITALA_N	400	2	-272	-327	-251	-285	-295	-215	-224	-207	-123	315
EAST	CHANDITALA_N	220	CHANDITALA_N	400	3	-272	-327	-251	-285	-295	-215	-224	-207	-123	315
EAST	KHARAGPR-WB	220	KHARAGPR-WB	400	1	-235	-273	-203	-250	-243	-165	-191	-155	-82	315
EAST	KHARAGPR-WB	220	KHARAGPR-WB	400	2	-235	-273	-203	-250	-243	-165	-191	-155	-82	315
EAST	KHARAGPR-WB	220	KHARAGPR-WB	400	3	-235	-273	-203	-250	-243	-165	-191	-155	-82	315

Area	From Name	Voltage	To Name	Voltage	Id	P-Sc1	P-Sc2	P-Sc3	P-Sc4	P-Sc5	P-Sc6	P-Sc7	P-Sc8	P-Sc9	MVA Rating
EAST	JEERAT	220	JEERAT	400	1	-229	-279	-214	-237	-244	-179	-192	-177	-104	315
EAST	JEERAT	220	JEERAT	400	2	-229	-279	-214	-237	-244	-179	-192	-177	-104	315
EAST	JEERAT	220	JEERAT	400	3	-229	-279	-214	-237	-244	-179	-192	-177	-104	315
EAST	JEERAT	220	JEERAT	400	4	-229	-279	-214	-237	-244	-179	-192	-177	-104	315
EAST	DURGAPUR TPS	220	DURGAPUR TPS	400	1	-291	-418	-315	-326	-386	-312	-310	-321	-247	500
EAST	DURGAPUR TPS	220	DURGAPUR TPS	400	2	-291	-418	-315	-326	-386	-312	-310	-321	-247	500
EAST	MEJIA-B	220	MEJIA-B	400	1	-225	-205	-201	-253	-200	-242	-245	-206	-199	315
EAST	MEJIA-B	220	MEJIA-B	400	2	-225	-205	-201	-253	-200	-242	-245	-206	-199	315
SOUTH	CHINAKAMPAL L	220	CUDP	400	1	-285	-151	-113	-291	-151	-95	-285	-128	-109	315
SOUTH	CHINAKAMPAL L	220	CUDP	400	2	-285	-151	-113	-291	-151	-95	-285	-128	-109	315
SOUTH	CHINAKAMPAL L	220	CUDP	400	3	-453	-240	-180	-462	-240	-151	-453	-203	-173	500
SOUTH	KOPPAL	220	KOPPAL	400	1	287	409	350	287	409	358	0	110	0	500
SOUTH	KOPPAL	220	KOPPAL	400	2	287	409	350	287	409	358	0	110	0	500
SOUTH	KOPPAL	220	KOPPAL	400	3	287	409	350	287	409	358	0	110	0	500
SOUTH	KOPPAL	220	KOPPAL	400	4	287	409	350	287	409	358	0	110	0	500
SOUTH	KOPPAL	220	KOPPAL	400	5	287	409	350	287	409	358	0	110	0	500

- Note: Highlighted cell indicates Power flow > 80% of MVA rating

Annex-2.5

Over Voltage Nodes

400V Bus Voltage >1.05 PU

Area Name	Bus Name	V-Sc1	V-Sc2	V-Sc3	V-Sc4	V-Sc5	V-Sc6	V-Sc7	V-Sc8	V-Sc9	Max
WEST	BHACHAUNDA	1.03	1.03	1.04	1.06	1.03	1.03	1.04	1.04	1.05	1.06
WEST	SHIVLAKHAPS	1.05	1.06	1.07	1.07	1.06	1.06	1.06	1.06	1.07	1.07
WEST	BHUS-I KHADK	1.01	1.02	1.06	1.04	1.04	1.04	1.02	1.01	1.04	1.06
WEST	BHUS-II DEEP	1.01	1.02	1.05	1.04	1.04	1.04	1.02	1.01	1.04	1.05
WEST	JAIGAD II	1.09	0.97	1.01	1.11	0.97	0.97	1.00	0.97	0.99	1.11
WEST	DOLVI	1.08	0.95	1.00	1.10	0.95	0.96	1.00	0.95	0.98	1.10
WEST	MALEGAON400	1.01	1.03	1.05	1.03	1.03	1.03	1.01	1.02	1.04	1.05
WEST	WARDHA SPLT	1.01	1.04	1.05	1.01	1.04	1.04	1.01	1.02	1.03	1.05
EAST	RNC-SIPT FSC	1.04	1.04	1.01	1.09	1.03	0.98	1.00	0.97	0.99	1.09
EAST	RNC-SIPT FSC	1.04	1.04	1.02	1.09	1.03	0.98	1.00	0.97	1.03	1.09
SOUTH	HINDPR40	1.00	1.01	1.02	1.00	1.01	1.03	1.01	1.02	1.05	1.05
SOUTH	MUDN400	1.01	1.05	1.00	1.02	1.04	1.07	1.04	1.01	1.08	1.08
SOUTH	TALARICH	1.01	1.02	1.03	1.01	1.02	1.03	1.02	1.03	1.05	1.05
SOUTH	KONDPRM	1.02	1.02	1.03	1.02	1.02	1.03	1.02	1.03	1.05	1.05
SOUTH	URVKND	1.00	1.02	1.02	1.00	1.01	1.03	1.02	1.02	1.05	1.05
SOUTH	KALIKIRI	1.00	1.04	1.03	1.01	1.03	1.05	1.03	1.02	1.06	1.06
SOUTH	RAMGUNDM STP	1.01	1.05	1.04	1.01	1.04	1.06	1.00	1.01	1.02	1.06
SOUTH	KHAMMAM	1.00	1.03	1.03	1.00	1.03	1.05	1.00	1.02	1.03	1.05
SOUTH	MAMIDIPALLY	1.00	1.03	1.04	1.00	1.03	1.05	1.01	1.01	1.03	1.05
SOUTH	KOTH-VI	1.01	1.03	1.03	1.01	1.03	1.05	1.01	1.02	1.03	1.05
SOUTH	SHANKARPALLY	1.00	1.04	1.04	1.01	1.04	1.06	1.01	1.02	1.03	1.06
SOUTH	MALKARM4	1.01	1.04	1.04	1.01	1.04	1.06	1.01	1.02	1.03	1.06

Area Name	Bus Name	V-Sc1	V-Sc2	V-Sc3	V-Sc4	V-Sc5	V-Sc6	V-Sc7	V-Sc8	V-Sc9	Max
SOUTH	SURYPET4	1.01	1.04	1.04	1.01	1.04	1.06	1.02	1.03	1.04	1.06
SOUTH	RAIDURG	1.01	1.05	1.05	1.02	1.05	1.07	1.01	1.03	1.05	1.07
SOUTH	DAMARACHRLA	1.00	1.03	1.04	1.01	1.03	1.05	1.00	1.00	1.00	1.05
SOUTH	WARANGAL	1.00	1.04	1.03	1.00	1.03	1.05	1.01	1.02	1.03	1.05
SOUTH	KOTH-VII	1.01	1.03	1.03	1.01	1.03	1.05	1.01	1.02	1.03	1.05
SOUTH	JULURUPADU	1.01	1.03	1.03	1.02	1.04	1.05	1.01	1.02	1.03	1.05
SOUTH	MAH-TS SEC-B	1.00	1.04	1.04	1.00	1.03	1.05	1.01	1.01	1.03	1.05
SOUTH	KETHIREDDYPA	1.01	1.05	1.05	1.01	1.04	1.07	1.01	1.03	1.04	1.07
SOUTH	JANAGAON	1.01	1.04	1.03	1.02	1.03	1.05	1.01	1.01	1.02	1.05
SOUTH	YADADRI TPP	1.00	1.03	1.04	1.01	1.03	1.05	1.00	1.00	1.00	1.05
SOUTH	CHOUTTUPPAL	1.00	1.04	1.04	1.01	1.04	1.06	1.01	1.02	1.02	1.06
WEST	BHACHAUNDA	1.03	1.03	1.04	1.06	1.03	1.03	1.04	1.04	1.05	1.06
WEST	SHIVLAKHAPS	1.05	1.06	1.07	1.07	1.06	1.06	1.06	1.06	1.07	1.07
WEST	BHUS-I KHADK	1.01	1.02	1.06	1.04	1.04	1.04	1.02	1.01	1.04	1.06
WEST	BHUS-II DEEP	1.01	1.02	1.05	1.04	1.04	1.04	1.02	1.01	1.04	1.05
WEST	JAIGAD II	1.09	0.97	1.01	1.11	0.97	0.97	1.00	0.97	0.99	1.11
WEST	DOLVI	1.08	0.95	1.00	1.10	0.95	0.96	1.00	0.95	0.98	1.10
WEST	MALEGAON400	1.01	1.03	1.05	1.03	1.03	1.03	1.01	1.02	1.04	1.05
WEST	WARDHA SPLT	1.01	1.04	1.05	1.01	1.04	1.04	1.01	1.02	1.03	1.05
EAST	RNC-SIPT FSC	1.04	1.04	1.01	1.09	1.03	0.98	1.00	0.97	0.99	1.09
EAST	RNC-SIPT FSC	1.04	1.04	1.02	1.09	1.03	0.98	1.00	0.97	1.03	1.09
SOUTH	HINDPR40	1.00	1.01	1.02	1.00	1.01	1.03	1.01	1.02	1.05	1.05
SOUTH	MUDN400	1.01	1.05	1.00	1.02	1.04	1.07	1.04	1.01	1.08	1.08
SOUTH	TALARICH	1.01	1.02	1.03	1.01	1.02	1.03	1.02	1.03	1.05	1.05
SOUTH	KONDPRM	1.02	1.02	1.03	1.02	1.02	1.03	1.02	1.03	1.05	1.05
SOUTH	URVKND	1.00	1.02	1.02	1.00	1.01	1.03	1.02	1.02	1.05	1.05
SOUTH	KALIKIRI	1.00	1.04	1.03	1.01	1.03	1.05	1.03	1.02	1.06	1.06

Area Name	Bus Name	V-Sc1	V-Sc2	V-Sc3	V-Sc4	V-Sc5	V-Sc6	V-Sc7	V-Sc8	V-Sc9	Max
SOUTH	RAMGUNDM STP	1.01	1.05	1.04	1.01	1.04	1.06	1.00	1.01	1.02	1.06
SOUTH	KHAMMAM	1.00	1.03	1.03	1.00	1.03	1.05	1.00	1.02	1.03	1.05
SOUTH	MAMIDIPALLY	1.00	1.03	1.04	1.00	1.03	1.05	1.01	1.01	1.03	1.05
SOUTH	KOTH-VI	1.01	1.03	1.03	1.01	1.03	1.05	1.01	1.02	1.03	1.05
SOUTH	SHANKARPALLY	1.00	1.04	1.04	1.01	1.04	1.06	1.01	1.02	1.03	1.06
SOUTH	MALKARM4	1.01	1.04	1.04	1.01	1.04	1.06	1.01	1.02	1.03	1.06
SOUTH	SURYPET4	1.01	1.04	1.04	1.01	1.04	1.06	1.02	1.03	1.04	1.06
SOUTH	RAIDURG	1.01	1.05	1.05	1.02	1.05	1.07	1.01	1.03	1.05	1.07
SOUTH	DAMARACHRLA	1.00	1.03	1.04	1.01	1.03	1.05	1.00	1.00	1.00	1.05
SOUTH	WARANGAL	1.00	1.04	1.03	1.00	1.03	1.05	1.01	1.02	1.03	1.05
SOUTH	KOTH-VII	1.01	1.03	1.03	1.01	1.03	1.05	1.01	1.02	1.03	1.05
SOUTH	JULURUPADU	1.01	1.03	1.03	1.02	1.04	1.05	1.01	1.02	1.03	1.05
SOUTH	MAH-TS SEC-B	1.00	1.04	1.04	1.00	1.03	1.05	1.01	1.01	1.03	1.05
SOUTH	KETHIREDDYPA	1.01	1.05	1.05	1.01	1.04	1.07	1.01	1.03	1.04	1.07
SOUTH	JANAGAON	1.01	1.04	1.03	1.02	1.03	1.05	1.01	1.01	1.02	1.05
SOUTH	YADADRI TPP	1.00	1.03	1.04	1.01	1.03	1.05	1.00	1.00	1.00	1.05
SOUTH	CHOUTTUPPAL	1.00	1.04	1.04	1.01	1.04	1.06	1.01	1.02	1.02	1.06
WEST	BHACHAUNDA	1.03	1.03	1.04	1.06	1.03	1.03	1.04	1.04	1.05	1.06
WEST	SHIVLAKHAPS	1.05	1.06	1.07	1.07	1.06	1.06	1.06	1.06	1.07	1.07
WEST	BHUS-I KHADK	1.01	1.02	1.06	1.04	1.04	1.04	1.02	1.01	1.04	1.06
WEST	BHUS-II DEEP	1.01	1.02	1.05	1.04	1.04	1.04	1.02	1.01	1.04	1.05
WEST	JAIGAD II	1.09	0.97	1.01	1.11	0.97	0.97	1.00	0.97	0.99	1.11
WEST	DOLVI	1.08	0.95	1.00	1.10	0.95	0.96	1.00	0.95	0.98	1.10
WEST	MALEGAON400	1.01	1.03	1.05	1.03	1.03	1.03	1.01	1.02	1.04	1.05
WEST	WARDHA SPLT	1.01	1.04	1.05	1.01	1.04	1.04	1.01	1.02	1.03	1.05
EAST	RNC-SIPT FSC	1.04	1.04	1.01	1.09	1.03	0.98	1.00	0.97	0.99	1.09
EAST	RNC-SIPT FSC	1.04	1.04	1.02	1.09	1.03	0.98	1.00	0.97	1.03	1.09

Area Name	Bus Name	V-Sc1	V-Sc2	V-Sc3	V-Sc4	V-Sc5	V-Sc6	V-Sc7	V-Sc8	V-Sc9	Max
SOUTH	HINDPR40	1.00	1.01	1.02	1.00	1.01	1.03	1.01	1.02	1.05	1.05
SOUTH	MUDN400	1.01	1.05	1.00	1.02	1.04	1.07	1.04	1.01	1.08	1.08
SOUTH	TALARICH	1.01	1.02	1.03	1.01	1.02	1.03	1.02	1.03	1.05	1.05
SOUTH	KONDPRM	1.02	1.02	1.03	1.02	1.02	1.03	1.02	1.03	1.05	1.05
SOUTH	URVKND	1.00	1.02	1.02	1.00	1.01	1.03	1.02	1.02	1.05	1.05
SOUTH	KALIKIRI	1.00	1.04	1.03	1.01	1.03	1.05	1.03	1.02	1.06	1.06
SOUTH	RAMGUNDM STP	1.01	1.05	1.04	1.01	1.04	1.06	1.00	1.01	1.02	1.06
SOUTH	KHAMMAM	1.00	1.03	1.03	1.00	1.03	1.05	1.00	1.02	1.03	1.05
SOUTH	MAMIDIPALLY	1.00	1.03	1.04	1.00	1.03	1.05	1.01	1.01	1.03	1.05
SOUTH	KOTH-VI	1.01	1.03	1.03	1.01	1.03	1.05	1.01	1.02	1.03	1.05
SOUTH	SHANKARPALLY	1.00	1.04	1.04	1.01	1.04	1.06	1.01	1.02	1.03	1.06
SOUTH	MALKARM4	1.01	1.04	1.04	1.01	1.04	1.06	1.01	1.02	1.03	1.06
SOUTH	SURYPET4	1.01	1.04	1.04	1.01	1.04	1.06	1.02	1.03	1.04	1.06
SOUTH	RAIDURG	1.01	1.05	1.05	1.02	1.05	1.07	1.01	1.03	1.05	1.07
SOUTH	DAMARACHRLA	1.00	1.03	1.04	1.01	1.03	1.05	1.00	1.00	1.00	1.05
SOUTH	WARANGAL	1.00	1.04	1.03	1.00	1.03	1.05	1.01	1.02	1.03	1.05
SOUTH	KOTH-VII	1.01	1.03	1.03	1.01	1.03	1.05	1.01	1.02	1.03	1.05
SOUTH	JULURUPADU	1.01	1.03	1.03	1.02	1.04	1.05	1.01	1.02	1.03	1.05
SOUTH	MAH-TS SEC-B	1.00	1.04	1.04	1.00	1.03	1.05	1.01	1.01	1.03	1.05
SOUTH	KETHIREDDYPA	1.01	1.05	1.05	1.01	1.04	1.07	1.01	1.03	1.04	1.07
SOUTH	JANAGAON	1.01	1.04	1.03	1.02	1.03	1.05	1.01	1.01	1.02	1.05
SOUTH	YADADRI TPP	1.00	1.03	1.04	1.01	1.03	1.05	1.00	1.00	1.00	1.05
SOUTH	CHOUTTUPPAL	1.00	1.04	1.04	1.01	1.04	1.06	1.01	1.02	1.02	1.06
WEST	BHACHAUNDA	1.03	1.03	1.04	1.06	1.03	1.03	1.04	1.04	1.05	1.06
WEST	SHIVLAKHAPS	1.05	1.06	1.07	1.07	1.06	1.06	1.06	1.06	1.07	1.07
WEST	BHUS-I KHADK	1.01	1.02	1.06	1.04	1.04	1.04	1.02	1.01	1.04	1.06
WEST	BHUS-II DEEP	1.01	1.02	1.05	1.04	1.04	1.04	1.02	1.01	1.04	1.05

Area Name	Bus Name	V-Sc1	V-Sc2	V-Sc3	V-Sc4	V-Sc5	V-Sc6	V-Sc7	V-Sc8	V-Sc9	Max
WEST	JAIGAD II	1.09	0.97	1.01	1.11	0.97	0.97	1.00	0.97	0.99	1.11
WEST	DOLVI	1.08	0.95	1.00	1.10	0.95	0.96	1.00	0.95	0.98	1.10
WEST	MALEGAON400	1.01	1.03	1.05	1.03	1.03	1.03	1.01	1.02	1.04	1.05
WEST	WARDHA SPLT	1.01	1.04	1.05	1.01	1.04	1.04	1.01	1.02	1.03	1.05
EAST	RNC-SIPT FSC	1.04	1.04	1.01	1.09	1.03	0.98	1.00	0.97	0.99	1.09
EAST	RNC-SIPT FSC	1.04	1.04	1.02	1.09	1.03	0.98	1.00	0.97	1.03	1.09
SOUTH	HINDPR40	1.00	1.01	1.02	1.00	1.01	1.03	1.01	1.02	1.05	1.05
SOUTH	MUDN400	1.01	1.05	1.00	1.02	1.04	1.07	1.04	1.01	1.08	1.08
SOUTH	TALARICH	1.01	1.02	1.03	1.01	1.02	1.03	1.02	1.03	1.05	1.05
SOUTH	KONDPRM	1.02	1.02	1.03	1.02	1.02	1.03	1.02	1.03	1.05	1.05
SOUTH	URVKND	1.00	1.02	1.02	1.00	1.01	1.03	1.02	1.02	1.05	1.05
SOUTH	KALIKIRI	1.00	1.04	1.03	1.01	1.03	1.05	1.03	1.02	1.06	1.06
SOUTH	RAMGUNDM STP	1.01	1.05	1.04	1.01	1.04	1.06	1.00	1.01	1.02	1.06
SOUTH	KHAMMAM	1.00	1.03	1.03	1.00	1.03	1.05	1.00	1.02	1.03	1.05
SOUTH	MAMIDIPALLY	1.00	1.03	1.04	1.00	1.03	1.05	1.01	1.01	1.03	1.05
SOUTH	KOTH-VI	1.01	1.03	1.03	1.01	1.03	1.05	1.01	1.02	1.03	1.05
SOUTH	SHANKARPALLY	1.00	1.04	1.04	1.01	1.04	1.06	1.01	1.02	1.03	1.06
SOUTH	MALKARM4	1.01	1.04	1.04	1.01	1.04	1.06	1.01	1.02	1.03	1.06
SOUTH	SURYPET4	1.01	1.04	1.04	1.01	1.04	1.06	1.02	1.03	1.04	1.06
SOUTH	RAIDURG	1.01	1.05	1.05	1.02	1.05	1.07	1.01	1.03	1.05	1.07
SOUTH	DAMARACHRLA	1.00	1.03	1.04	1.01	1.03	1.05	1.00	1.00	1.00	1.05
SOUTH	WARANGAL	1.00	1.04	1.03	1.00	1.03	1.05	1.01	1.02	1.03	1.05
SOUTH	KOTH-VII	1.01	1.03	1.03	1.01	1.03	1.05	1.01	1.02	1.03	1.05
SOUTH	JULURUPADU	1.01	1.03	1.03	1.02	1.04	1.05	1.01	1.02	1.03	1.05
SOUTH	MAH-TS SEC-B	1.00	1.04	1.04	1.00	1.03	1.05	1.01	1.01	1.03	1.05
SOUTH	KETHIREDDYPA	1.01	1.05	1.05	1.01	1.04	1.07	1.01	1.03	1.04	1.07
SOUTH	JANAGAON	1.01	1.04	1.03	1.02	1.03	1.05	1.01	1.01	1.02	1.05

Area Name	Bus Name	V-Sc1	V-Sc2	V-Sc3	V-Sc4	V-Sc5	V-Sc6	V-Sc7	V-Sc8	V-Sc9	Max
SOUTH	YADADRI TPP	1.00	1.03	1.04	1.01	1.03	1.05	1.00	1.00	1.00	1.05
SOUTH	CHOUTTUPPAL	1.00	1.04	1.04	1.01	1.04	1.06	1.01	1.02	1.02	1.06

- Note: Highlighted cell indicates 400kV Bus Voltage > 1.05 P.U.

765kV Bus Voltage >1.05 PU

Area Name	Bus Name	V-Sc1	V-Sc2	V-Sc3	V-Sc4	V-Sc5	V-Sc6	V-Sc7	V-Sc8	V-Sc9	Max
WEST	NR-RAJKOT	1.03	1.04	1.04	1.04	1.05	1.03	1.03	1.06	1.04	1.06
SOUTH	UPPUR	1.02	1.04	1.01	1.01	1.03	1.02	1.05	1.00	1.00	1.05
SOUTH	VIRUDHNAGAR	1.01	1.03	1.01	1.01	1.03	1.02	1.06	1.01	1.01	1.06

- Note: Highlighted cell indicates 765 kV Bus Voltage > 1.05 P.U.

Under Voltage Nodes

400kV Bus Voltage <0.95 PU

Area Name	Bus Name	V-Sc1	V-Sc2	V-Sc3	V-Sc4	V-Sc5	V-Sc6	V-Sc7	V-Sc8	V-Sc9	Min
NORTH	MERTA	0.98	1.03	1.00	0.94	0.99	1.00	1.00	1.00	1.01	0.94
NORTH	BHADLA	0.98	1.02	1.00	0.95	0.99	1.00	0.99	1.00	1.01	0.95
NORTH	RATANGAR	0.99	1.03	1.00	0.95	0.99	1.00	1.00	1.00	1.01	0.95
NORTH	DEEDWANA	0.98	1.04	1.00	0.94	0.99	1.01	1.00	1.00	1.01	0.94
NORTH	JODH KANKANI	0.98	1.04	1.01	0.95	1.01	1.01	1.00	1.01	1.02	0.95
NORTH	BIKANE-4	0.97	1.03	1.01	0.93	1.00	1.01	1.00	1.01	1.01	0.93
NORTH	SURATG-4	0.98	1.01	1.00	0.94	1.00	1.00	1.00	1.00	1.00	0.94
NORTH	SIKAR NEW	1.00	1.03	1.02	0.94	1.01	1.02	1.00	1.02	1.01	0.94
NORTH	HANUMAN	0.98	1.03	1.00	0.94	1.00	1.01	1.01	1.00	1.01	0.94

- Highlighted cell indicates 400kV Bus Voltage <0.95 P.U.

765kV Bus Voltage <0.95 PU

Area Name	Bus Name	V-Sc1	V-Sc2	V-Sc3	V-Sc4	V-Sc5	V-Sc6	V-Sc7	V-Sc8	V-Sc9	Min
NORTH	BHIWN-PG	1.00	1.02	1.00	0.95	1.00	1.00	1.00	1.00	1.00	0.95
NORTH	NARELA ISTS	1.01	1.02	1.00	0.95	0.99	1.00	1.00	1.00	1.01	0.95
NORTH	JHATI-PG	1.00	1.02	1.00	0.95	0.99	1.00	1.00	1.00	1.01	0.95
NORTH	SIKAR NEW	1.00	1.03	1.02	0.94	1.01	1.02	0.99	1.02	1.02	0.94
NORTH	KHETRI	1.00	1.03	1.02	0.94	1.01	1.02	1.00	1.02	1.02	0.94

- Highlighted cell indicates 765kV Bus Voltage <0.95 P.U.

Annex-2.6

N-1 Contingency of 765 kV Transmission Lines

S. No.	Monitored Element	Contingency	Maximum Flow	Flow under Contingency	Rate	% loading	Scenario
1.	518062 NIZAMABAD 765.00 518888 NIZAMBD2_7 765.00 1	OPEN LINE FROM BUS 518062 [NIZAMABAD 765.00] TO BUS 518888 [NIZAMBD2_7 765.00] CKT 2	4634	4671	3500	133.45	SC-1
2.	508007 CUDP800 765.00 508888 CUDP2_7 765.00 1	OPEN LINE FROM BUS 508007 [CUDP800 765.00] TO BUS 508888 [CUDP2_7 765.00] CKT 2	4390	4483	3500	128.09	SC-1
3.	508049 KURNOOL-III 765.00 518051 MAHESHWARAM 765.00 1	OPEN LINE FROM BUS 508049 [KURNOOL-III 765.00] TO BUS 518051 [MAHESHWARAM 765.00] CKT 2	3773	3818	3500	109.09	SC-1
4.	508028 KURL800 765.00 508049 KURNOOL-III 765.00 1	OPEN LINE FROM BUS 508028 [KURL800 765.00] TO BUS 508049 [KURNOOL-III 765.00] CKT 2	3488	3536	3500	101.04	SC-1
5.	157708 JHATI-PG 765.00 167774 KHETRI 765.00 1	OPEN LINE FROM BUS 157708 [JHATI-PG 765.00] TO BUS 167774 [KHETRI 765.00] CKT 2	3293	3291	3500	94.03	SC-1
6.	167484 BHADLA-3 765.00 167497 SIKAR NEW 765.00 2	OPEN LINE FROM BUS 167484 [BHADLA-3 765.00] TO BUS 167497 [SIKAR NEW 765.00] CKT 1	3236	3270	3500	93.43	SC-1
7.	167484 BHADLA-3 765.00 167497 SIKAR NEW 765.00 1	OPEN LINE FROM BUS 167484 [BHADLA-3 765.00] TO BUS 167497 [SIKAR NEW 765.00] CKT 2	3232	3256	3500	93.02	SC-1
8.	358035 VADODARA 765.00 358111 VATAMAN 765.00 1	OPEN LINE FROM BUS 358035 [VADODARA 765.00] TO BUS 358111 [VATAMAN 765.00] CKT 2	3283	3255	3500	92.99	SC-1
9.	177265 GNOIDAUP 765.00 177512 ALIGARH 765.00 1	OPEN LINE FROM BUS 157001 [NARELA ISTS 765.00] TO BUS 177707 [MERUT-PG 765.00] CKT 2	3233	3192	3500	91.21	SC-1
10.	318031 TAMNAR 765.00 318998 DHARAM_SPL 765.00 1	OPEN LINE FROM BUS 318031 [TAMNAR 765.00] TO BUS 318998 [DHARAM_SPL 765.00] CKT 2	3749	3713	3500	106.08	SC-2

S. No.	Monitored Element	Contingency	Maximum Flow	Flow under Contingency	Rate	% loading	Scenario
11.	368024 SASAN 765.00 368025 VIN-POOL 765.00 1	OPEN LINE FROM BUS 368024 [SASAN 765.00] TO BUS 368025 [VIN-POOL 765.00] CKT 2	3257	3257	3500	93.06	SC-2
12.	528002 NARENDERA NW765.00 528888 KOPPAL PS-II765.00 1	OPEN LINE FROM BUS 528002 [NARENDERA NW765.00] TO BUS 528888 [KOPPAL PS-II765.00] CKT 2	3116	3194	3500	91.26	SC-2
13.	368024 SASAN 765.00 368025 VIN-POOL 765.00 2	OPEN LINE FROM BUS 368024 [SASAN 765.00] TO BUS 368025 [VIN-POOL 765.00] CKT 1	3187	3187	3500	91.07	SC-2
14.	508007 CUDP800 765.00 508888 CUDP2_7 765.00 1	OPEN LINE FROM BUS 508007 [CUDP800 765.00] TO BUS 508888 [CUDP2_7 765.00] CKT 2	3150	3166	3500	90.46	SC-2
15.	518062 NIZAMABAD 765.00 518888 NIZAMBD2_7 765.00 1	OPEN LINE FROM BUS 518062 [NIZAMABAD 765.00] TO BUS 518888 [NIZAMBD2_7 765.00] CKT 2	4981	5059	3500	144.55	SC-4
16.	508007 CUDP800 765.00 508888 CUDP2_7 765.00 1	OPEN LINE FROM BUS 508007 [CUDP800 765.00] TO BUS 508888 [CUDP2_7 765.00] CKT 2	4601	4710	3500	134.56	SC-4
17.	508049 KURNOOL-III 765.00 518051 MAHESHWARAM 765.00 1	OPEN LINE FROM BUS 508049 [KURNOOL-III 765.00] TO BUS 518051 [MAHESHWARAM 765.00] CKT 2	4112	4179	3500	119.41	SC-4
18.	177265 GNOIDAUP 765.00 177512 ALIGARH 765.00 1	OPEN LINE FROM BUS 157001 [NARELA ISTS 765.00] TO BUS 177707 [MERUT-PG 765.00] CKT 2	3866	3981	3500	113.73	SC-4
19.	508028 KURL800 765.00 508049 KURNOOL-III 765.00 1	OPEN LINE FROM BUS 508028 [KURL800 765.00] TO BUS 508049 [KURNOOL-III 765.00] CKT 2	3635	3703	3500	105.81	SC-4
20.	157708 JHATI-PG 765.00 167774 KHETRI 765.00 1	OPEN LINE FROM BUS 157708 [JHATI-PG 765.00] TO BUS 167774 [KHETRI 765.00] CKT 2	3448	3657	3500	104.48	SC-4
21.	358035 VADODARA 765.00 358111 VATAMAN 765.00 1	OPEN LINE FROM BUS 358035 [VADODARA 765.00] TO BUS 358111 [VATAMAN 765.00] CKT 2	3586	3526	3500	100.74	SC-4
22.	157001 NARELA ISTS 765.00 177707 MERUT-PG 765.00 2	OPEN LINE FROM BUS 137703 [MOGA-PG 765.00] TO BUS 177707 [MERUT-PG 765.00] CKT 1	3295	3512	3500	100.35	SC-4

S. No.	Monitored Element	Contingency	Maximum Flow	Flow under Contingency	Rate	% loading	Scenario
23.	518051 MAHESHWARAM 765.00 528014 BIDAR PS SZ 765.00 1	OPEN LINE FROM BUS 518051 [MAHESHWARAM 765.00] TO BUS 528014 [BIDAR PS SZ 765.00] CKT 2	3361	3422	3500	97.76	SC-4
24.	167417 AJMER-NW 765.00 167773 JAIPUR 765.00 1	OPEN LINE FROM BUS 167417 [AJMER-NW 765.00] TO BUS 167773 [JAIPUR 765.00] CKT 2	3205	3368	3500	96.22	SC-4
25.	167417 AJMER-NW 765.00 167502 BEAWAR 765.00 1	OPEN LINE FROM BUS 167417 [AJMER-NW 765.00] TO BUS 167502 [BEAWAR 765.00] CKT 2	3115	3218	3500	91.95	SC-4
26.	167458 BIKANER-NW 765.00 167459 BHADLA PG 765.00 1	OPEN LINE FROM BUS 167458 [BIKANER-NW 765.00] TO BUS 167459 [BHADLA PG 765.00] CKT 2	3017	3183	3500	90.93	SC-4
27.	318031 TAMNAR 765.00 318998 DHRAM_SPL 765.00 1	OPEN LINE FROM BUS 318031 [TAMNAR 765.00] TO BUS 318998 [DHRAM_SPL 765.00] CKT 2	3992	3956	3500	113.03	SC-5
28.	177000 VARNASI8 765.00 368025 VIN-POOL 765.00 1	OPEN LINE FROM BUS 177000 [VARNASI8 765.00] TO BUS 368025 [VIN-POOL 765.00] CKT 2	3477	3451	3500	98.59	SC-5
29.	368024 SASAN 765.00 368025 VIN- POOL 765.00 1	OPEN LINE FROM BUS 368024 [SASAN 765.00] TO BUS 368025 [VIN-POOL 765.00] CKT 2	3260	3260	3500	93.15	SC-5
30.	378900 BOISAR-II 765.00 378901 PUNE-III 765.00 1	OPEN LINE FROM BUS 378045 [PUNE-PG-GIS 765.00] TO BUS 378051 [PADGHEGIS 765.00] CKT 1	3251	3200	3500	91.42	SC-5
31.	368024 SASAN 765.00 368025 VIN- POOL 765.00 2	OPEN LINE FROM BUS 368024 [SASAN 765.00] TO BUS 368025 [VIN-POOL 765.00] CKT 1	3198	3198	3500	91.36	SC-5
32.	518062 NIZAMABAD 765.00 518888 NIZAMBD2_7 765.00 1	OPEN LINE FROM BUS 518062 [NIZAMABAD 765.00] TO BUS 518888 [NIZAMBD2_7 765.00] CKT 2	3973	3970	3500	113.44	SC-7
33.	508007 CUDP800 765.00 508888 CUDP2_7 765.00 1	OPEN LINE FROM BUS 508007 [CUDP800 765.00] TO BUS 508888 [CUDP2_7 765.00] CKT 2	3944	3931	3500	112.33	SC-7
34.	518051 MAHESHWARAM 765.00 528014 BIDAR PS SZ 765.00 1	OPEN LINE FROM BUS 518051 [MAHESHWARAM 765.00] TO BUS 528014 [BIDAR PS SZ 765.00] CKT 2	3361	3422	3500	97.76	SC-4

S. No.	Monitored Element	Contingency	Maximum Flow	Flow under Contingency	Rate	% loading	Scenario
35.	167417 AJMER-NW 765.00 167773 JAIPUR 765.00 1	OPEN LINE FROM BUS 167417 [AJMER-NW 765.00] TO BUS 167773 [JAIPUR 765.00] CKT 2	3205	3368	3500	96.22	SC-4
36.	167417 AJMER-NW 765.00 167502 BEAWAR 765.00 1	OPEN LINE FROM BUS 167417 [AJMER-NW 765.00] TO BUS 167502 [BEAWAR 765.00] CKT 2	3115	3218	3500	91.95	SC-4
37.	167458 BIKANER-NW 765.00 167459 BHADLA PG 765.00 1	OPEN LINE FROM BUS 167458 [BIKANER-NW 765.00] TO BUS 167459 [BHADLA PG 765.00] CKT 2	3017	3183	3500	90.93	SC-4
38.	318031 TAMNAR 765.00 318998 DHRAM_SPL 765.00 1	OPEN LINE FROM BUS 318031 [TAMNAR 765.00] TO BUS 318998 [DHRAM_SPL 765.00] CKT 2	3992	3956	3500	113.03	SC-5
39.	177000 VARNASI8 765.00 368025 VIN-POOL 765.00 1	OPEN LINE FROM BUS 177000 [VARNASI8 765.00] TO BUS 368025 [VIN-POOL 765.00] CKT 2	3477	3451	3500	98.59	SC-5
40.	368024 SASAN 765.00 368025 VIN- POOL 765.00 1	OPEN LINE FROM BUS 368024 [SASAN 765.00] TO BUS 368025 [VIN-POOL 765.00] CKT 2	3260	3260	3500	93.15	SC-5
41.	378900 BOISAR-II 765.00 378901 PUNE-III 765.00 1	OPEN LINE FROM BUS 378045 [PUNE-PG-GIS 765.00] TO BUS 378051 [PADGHEGIS 765.00] CKT 1	3251	3200	3500	91.42	SC-5
42.	368024 SASAN 765.00 368025 VIN- POOL 765.00 2	OPEN LINE FROM BUS 368024 [SASAN 765.00] TO BUS 368025 [VIN-POOL 765.00] CKT 1	3198	3198	3500	91.36	SC-5
43.	518062 NIZAMABAD 765.00 518888 NIZAMBD2_7 765.00 1	OPEN LINE FROM BUS 518062 [NIZAMABAD 765.00] TO BUS 518888 [NIZAMBD2_7 765.00] CKT 2	3973	3970	3500	113.44	SC-7
44.	508007 CUDP800 765.00 508888 CUDP2_7 765.00 1	OPEN LINE FROM BUS 508007 [CUDP800 765.00] TO BUS 508888 [CUDP2_7 765.00] CKT 2	3944	3931	3500	112.33	SC-7

N-1 Contingency of 400 kV Transmission Lines

S. No.	Monitored Element	Contingency	Maximum Flow	Flow under Contingency	Rate	% loading	Scenario
1.	514002 HYDERABAD 400.00 514101 MAHESWRM 400.00 1	OPEN LINE FROM BUS 518051 [MAHESHWARAM 765.00] TO BUS 518079 [WARANGAL NEW765.00] CKT 1	1770	1804	874	206.38	SC-1
2.	114401 BAGLIHAR4 400.00 114476 NEWWANPO 400.00 1	OPEN LINE FROM BUS 114422 [KISHENPUR 400.00] TO BUS 114476 [NEWWANPO 400.00] CKT 1	1452	1452	857	169.41	SC-1
3.	504013 KURNOOL4 400.00 504028 KURL-NEW 400.00 1	OPEN LINE FROM BUS 504013 [KURNOOL4 400.00] TO BUS 504028 [KURL-NEW 400.00] CKT 2	1654	1656	1045	158.46	SC-1
4.	114541 KISTAWAR 400.00 114598 KIRU 400.00 1	OPEN LINE FROM BUS 114541 [KISTAWAR 400.00] TO BUS 114542 [PAKALDUL 400.00] CKT 1	1329	1329	857	155.11	SC-1
5.	504007 CUDP 400.00 504024 CHITOR 400.00 1	OPEN LINE FROM BUS 544084 [TIRUVLM SE-B400.00] TO BUS 544087 [TIRUVLM SE-A400.00] CKT 1	1258	1287	852	151.09	SC-1
6.	444010 SAGARDIGHI_4400.00 444019 FARAKKA 400.00 1	OPEN LINE FROM BUS 514888 [NIZAMBD2_4 400.00] TO BUS 518888 [NIZAMBD2_7 765.00] CKT 1	1445	1445	1093	132.24	SC-1
7.	144469 BHIWANI-PG 400.00 144480 JINDPG 400.00 1	OPEN LINE FROM BUS 144469 [BHIWANI-PG 400.00] TO BUS 144480 [JINDPG 400.00] CKT 2	1126	1131	857	131.98	SC-1
8.	144420 BHIWANI 400.00 144469 BHIWANI-PG 400.00 1	OPEN LINE FROM BUS 144469 [BHIWANI-PG 400.00] TO BUS 144480 [JINDPG 400.00] CKT 1	1078	1083	857	126.33	SC-1
9.	374002 KHARGAR 400.00 374217 NAVI-MUM 400.00 1	OPEN LINE FROM BUS 374002 [KHARGAR 400.00] TO BUS 374051 [PADGHEGIS 400.00] CKT 1	1013	1038	857	121.13	SC-1
10.	504007 CUDP 400.00 504025 ANANTPUR 400.00 1	OPEN LINE FROM BUS 504007 [CUDP 400.00] TO BUS 504025 [ANANTPUR 400.00] CKT 2	2647	2647	2186	121.11	SC-1
11.	374014 AURANGBD-I 400.00 374047 AURANGABD-II400.00 1	OPEN LINE FROM BUS 374014 [AURANGBD-I 400.00] TO BUS 374047 [AURANGABD-II400.00] CKT 2	1031	1020	857	119.06	SC-1

S. No.	Monitored Element	Contingency	Maximum Flow	Flow under Contingency	Rate	% loading	Scenario
12.	444074 PPSP_NEW 400.00 444075 PURULIAPS 400.00 1	OPEN LINE FROM BUS 444074 [PPSP_NEW 400.00] TO BUS 444075 [PURULIAPS 400.00] CKT 2	1003	1003	850	117.96	SC-1
13.	504013 KURNOOL4 400.00 514011 SSLBPH4 400.00 1	OPEN LINE FROM BUS 514002 [HYDERABAD 400.00] TO BUS 514101 [MAHESWRM 400.00] CKT 1	1217	1221	1045	116.85	SC-1
14.	524001 SMNH 400.00 524077 BIDADI 400.00 1	OPEN LINE FROM BUS 524001 [SMNH 400.00] TO BUS 524077 [BIDADI 400.00] CKT 2	924	957	852	112.36	SC-1
15.	544086 MALEKTT 400.00 544087 TIRUVLM SE-A400.00 1	OPEN LINE FROM BUS 544086 [MALEKTT 400.00] TO BUS 544087 [TIRUVLM SE-A400.00] CKT 2	920	949	850	111.62	SC-1
16.	114422 KISHENPUR 400.00 114476 NEWWANPO 400.00 1	OPEN LINE FROM BUS 114401 [BAGLIHAR4 400.00] TO BUS 114476 [NEWWANPO 400.00] CKT 1	1185	1198	1093	109.62	SC-1
17.	114422 KISHENPUR 400.00 124401 CHAMERA-2 400.00 1	OPEN LINE FROM BUS 114401 [BAGLIHAR4 400.00] TO BUS 114476 [NEWWANPO 400.00] CKT 1	906	916	857	106.87	SC-1
18.	174400 AGRAUP4 400.00 174922 AGRA 400.00 2	OPEN LINE FROM BUS 177265 [GNOIDAUP 765.00] TO BUS 177512 [ALIGARH 765.00] CKT 1	913	913	857	106.5	SC-1
19.	504026 VIJ-AP 400.00 504037 THALAYAPALEM400.00 1	OPEN LINE FROM BUS 504026 [VIJ-AP 400.00] TO BUS 504037 [THALAYAPALEM400.00] CKT 2	891	902	852	105.88	SC-1
20.	174438 LUCK4-PG 400.00 174451 LUCK74-P 400.00 1	OPEN LINE FROM BUS 174438 [LUCK4-PG 400.00] TO BUS 174451 [LUCK74-P 400.00] CKT 2	1819	1795	1714	104.71	SC-1
21.	124001 WANGTOO 400.00 124041 JANGI-THOPAN400.00 1	OPEN LINE FROM BUS 124001 [WANGTOO 400.00] TO BUS 124042 [SHANGTONG 400.00] CKT 1	895	894	857	104.37	SC-1
22.	514021 DICHPAL4 400.00 514061 NIZAMABAD 400.00 1	OPEN LINE FROM BUS 514021 [DICHPAL4 400.00] TO BUS 514061 [NIZAMABAD 400.00] CKT 2	2259	2270	2186	103.85	SC-1
23.	174002 BAGPAT 400.00 174905 MEERUT 400.00 1	OPEN LINE FROM BUS 174002 [BAGPAT 400.00] TO BUS 174905 [MEERUT 400.00] CKT 2	879	875	857	102.08	SC-1

S. No.	Monitored Element	Contingency	Maximum Flow	Flow under Contingency	Rate	% loading	Scenario
24.	124401 CHAMERA-2 400.00 124448 CHAM-POL 400.00 1	OPEN LINE FROM BUS 124401 [CHAMERA-2 400.00] TO BUS 124411 [CHAMERA-1 400.00] CKT 1	866	866	857	101.1	SC-1
25.	164429 CHIT-NEW 400.00 164492 JALORE 400.00 1	OPEN LINE FROM BUS 164429 [CHIT-NEW 400.00] TO BUS 164492 [JALORE 400.00] CKT 2	872	866	857	101.09	SC-1
26.	164400 MERTA 400.00 164434 JODH KANKANI400.00 1	OPEN LINE FROM BUS 167773 [JAIPUR 765.00] TO BUS 167799 [JODH KANKANI765.00] CKT 1	813	835	857	97.41	SC-1
27.	174491 KHURJA TPS 400.00 174512 ALIGARH 400.00 1	OPEN LINE FROM BUS 177265 [GNOIDAUP 765.00] TO BUS 177512 [ALIGARH 765.00] CKT 1	833	821	857	95.79	SC-1
28.	164460 FATEHGARH 400.00 164480 FATEHG-2 400.00 1	OPEN LINE FROM BUS 164460 [FATEHGARH 400.00] TO BUS 164480 [FATEHG-2 400.00] CKT 2	2072	2072	2186	94.77	SC-1
29.	174417 RIHAND-G 400.00 174433 RIHAN-HV 400.00 1	OPEN LINE FROM BUS 174417 [RIHAND-G 400.00] TO BUS 174433 [RIHAN-HV 400.00] CKT 2	1515	1515	1600	94.66	SC-1
30.	504026 VIJ-AP 400.00 504045 BURUGUBAN LI400.00 1	OPEN LINE FROM BUS 504026 [VIJ-AP 400.00] TO BUS 504045 [BURUGUBAN LI400.00] CKT 2	817	826	874	94.54	SC-1
31.	164481 FATEHG-3 400.00 164482 FATEHG-4 400.00 1	OPEN LINE FROM BUS 164481 [FATEHG-3 400.00] TO BUS 164482 [FATEHG-4 400.00] CKT 2	1981	1979	2100	94.22	SC-1
32.	164404 BHADLA 400.00 164456 BIKANE-4 400.00 1	OPEN LINE FROM BUS 164404 [BHADLA 400.00] TO BUS 164456 [BIKANE-4 400.00] CKT 2	1567	1598	1714	93.22	SC-1
33.	364189 DATIYA NEW4 400.00 364979 MORENA SP 400.00 1	OPEN LINE FROM BUS 364189 [DATIYA NEW4 400.00] TO BUS 364979 [MORENA SP 400.00] CKT 2	1989	2037	2186	93.17	SC-1
34.	154455 MUNDKA 400.00 154463 JHATIKALA-PG400.00 1	OPEN LINE FROM BUS 154455 [MUNDKA 400.00] TO BUS 154463 [JHATIKALA-PG400.00] CKT 2	1820	1850	1988	93.08	SC-1
35.	114001 LEH_PANG 400.00 114013 PANG400SP3 400.00 1	OPEN LINE FROM BUS 114001 [LEH_PANG 400.00] TO BUS 114013 [PANG400SP3 400.00] CKT 2	1578	1593	1714	92.96	SC-1

S. No.	Monitored Element	Contingency	Maximum Flow	Flow under Contingency	Rate	% loading	Scenario
36.	124401 CHAMERA-2 400.00 124411 CHAMERA-1 400.00 1	OPEN LINE FROM BUS 124401 [CHAMERA-2 400.00] TO BUS 124448 [CHAM-POL 400.00] CKT 1	796	796	857	92.87	SC-1
37.	504017 VEMAGIR4 400.00 504092 VEMAG-II 400.00 1	OPEN LINE FROM BUS 504017 [VEMAGIR4 400.00] TO BUS 504092 [VEMAG-II 400.00] CKT 2	1005	1012	1093	92.6	SC-1
38.	114001 LEH_PANG 400.00 114012 PANG400SP2 400.00 1	OPEN LINE FROM BUS 114001 [LEH_PANG 400.00] TO BUS 114012 [PANG400SP2 400.00] CKT 2	1578	1586	1714	92.55	SC-1
39.	114001 LEH_PANG 400.00 114008 PANG 400 SP1400.00 1	OPEN LINE FROM BUS 114001 [LEH_PANG 400.00] TO BUS 114008 [PANG 400 SP1400.00] CKT 2	1578	1579	1714	92.15	SC-1
40.	164484 BHADLA-3 400.00 164494 BHADLA-3 HVD400.00 1	OPEN LINE FROM BUS 164484 [BHADLA-3 400.00] TO BUS 164494 [BHADLA-3 HVD400.00] CKT 2	2004	2004	2186	91.66	SC-1
41.	444074 PPSP_NEW 400.00 474047 RANCHI-NEW 400.00 1	OPEN LINE FROM BUS 444074 [PPSP_NEW 400.00] TO BUS 474047 [RANCHI-NEW 400.00] CKT 2	1015	997	1093	91.24	SC-1
42.	544016 PUGALUR-NEW 400.00 544033 KARUR II 400.00 1	OPEN LINE FROM BUS 544016 [PUGALUR-NEW 400.00] TO BUS 544033 [KARUR II 400.00] CKT 2	1987	1987	2186	90.9	SC-1
43.	164402 BARMER-4 400.00 164413 RAJWEST 400.00 1	OPEN LINE FROM BUS 164110 [JAISALMER-2 400.00] TO BUS 164434 [JODH KANKANI400.00] CKT 1	770	776	857	90.51	SC-1
44.	174424 DADR-NCR 400.00 174454 DADR-HVD 400.00 1	OPEN LINE FROM BUS 174424 [DADR-NCR 400.00] TO BUS 174454 [DADR-HVD 400.00] CKT 2	1445	1445	1600	90.32	SC-1
45.	114541 KISTAWAR 400.00 114598 KIRU 400.00 1	OPEN LINE FROM BUS 114541 [KISTAWAR 400.00] TO BUS 114542 [PAKALDUL 400.00] CKT 1	1981	1981	857	231.15	SC-2
46.	114597 KWAR 400.00 114598 KIRU 400.00 1	OPEN LINE FROM BUS 114541 [KISTAWAR 400.00] TO BUS 114542 [PAKALDUL 400.00] CKT 1	1413	1413	1093	129.3	SC-2
47.	174000 MEJA 400.00 174474 ALLAHABA 400.00 1	OPEN LINE FROM BUS 174000 [MEJA 400.00] TO BUS 174474 [ALLAHABA 400.00] CKT 2	1017	1016	857	118.59	SC-2

S. No.	Monitored Element	Contingency	Maximum Flow	Flow under Contingency	Rate	% loading	Scenario
48.	114541 KISTAWAR 400.00 114542 PAKALDUL 400.00 1	OPEN LINE FROM BUS 114541 [KISTAWAR 400.00] TO BUS 114598 [KIRU 400.00] CKT 1	1984	1984	1714	115.77	SC-2
49.	174400 AGRAUP4 400.00 174922 AGRA 400.00 2	OPEN LINE FROM BUS 174414 [AGRANEW 400.00] TO BUS 174922 [AGRA 400.00] CKT 2	975	975	857	113.72	SC-2
50.	444010 SAGARDIGHI_4400.00 444019 FARAKKA 400.00 1	OPEN LINE FROM BUS 504885 [ANANTPR2_4 400.00] TO BUS 508885 [ANANTPR2_7 765.00] CKT 1	1193	1193	1093	109.16	SC-2
51.	174927 GORAKHPU 400.00 814002 BUTWAL 400.00 1	OPEN LINE FROM BUS 174927 [GORAKHPU 400.00] TO BUS 814002 [BUTWAL 400.00] CKT 2	1844	1844	1714	107.6	SC-2
52.	114401 BAGLIHAR4 400.00 114476 NEWWANPO 400.00 1	OPEN LINE FROM BUS 114422 [KISHENPUR 400.00] TO BUS 114476 [NEWWANPO 400.00] CKT 1	910	910	857	106.22	SC-2
53.	524886 DAVANGR_4 400.00 524888 KOPPAL PS-II400.00 1	OPEN LINE FROM BUS 524886 [DAVANGR_4 400.00] TO BUS 524888 [KOPPAL PS-II400.00] CKT 2	2255	2255	2186	103.16	SC-2
54.	524887 GADAG PS-II 400.00 524888 KOPPAL PS-II400.00 1	OPEN LINE FROM BUS 524887 [GADAG PS-II 400.00] TO BUS 524888 [KOPPAL PS-II400.00] CKT 2	2210	2245	2186	102.72	SC-2
55.	544016 PUGALUR-NEW 400.00 544033 KARUR II 400.00 1	OPEN LINE FROM BUS 544016 [PUGALUR-NEW 400.00] TO BUS 544033 [KARUR II 400.00] CKT 2	2180	2180	2186	99.72	SC-2
56.	114542 PAKALDUL 400.00 114597 KWAR 400.00 1	OPEN LINE FROM BUS 114541 [KISTAWAR 400.00] TO BUS 114598 [KIRU 400.00] CKT 1	1069	1069	1093	97.82	SC-2
57.	134406 RAJPURA_TH4 400.00 134407 RAJPURA4 400.00 1	OPEN LINE FROM BUS 134406 [RAJPURA_TH4 400.00] TO BUS 134407 [RAJPURA4 400.00] CKT 2	832	832	857	97.06	SC-2
58.	504013 KURNOOL4 400.00 504028 KURL-NEW 400.00 1	OPEN LINE FROM BUS 504013 [KURNOOL4 400.00] TO BUS 504028 [KURL-NEW 400.00] CKT 2	1013	993	1045	95.06	SC-2
59.	174417 RIHAND-G 400.00 174433 RIHAN-HV 400.00 1	OPEN LINE FROM BUS 174417 [RIHAND-G 400.00] TO BUS 174433 [RIHAN-HV 400.00] CKT 2	1515	1515	1600	94.66	SC-2

S. No.	Monitored Element	Contingency	Maximum Flow	Flow under Contingency	Rate	% loading	Scenario
60.	174424 DADR-NCR 400.00 174454 DADR-HVD 400.00 1	OPEN LINE FROM BUS 174424 [DADR-NCR 400.00] TO BUS 174454 [DADR-HVD 400.00] CKT 2	1507	1507	1600	94.17	SC-2
61.	424018 ANGUL-A 400.00 424030 JINDAL-JITPL400.00 1	OPEN LINE FROM BUS 424018 [ANGUL-A 400.00] TO BUS 424030 [JINDAL-JITPL400.00] CKT 2	1014	1014	1093	92.78	SC-2
62.	314029 RAIGARH_POOL400.00 314045 LARA STPP 400.00 1	OPEN LINE FROM BUS 314029 [RAIGARH_POOL400.00] TO BUS 314045 [LARA STPP 400.00] CKT 2	954	954	1050	90.84	SC-2
63.	374024 RGPPL 400.00 374028 NAGOTHANE 400.00 1	OPEN LINE FROM BUS 374024 [RGPPL 400.00] TO BUS 374028 [NAGOTHANE 400.00] CKT 2	758	771	857	90.02	SC-2
64.	114541 KISTAWAR 400.00 114598 KIRU 400.00 1	OPEN LINE FROM BUS 114541 [KISTAWAR 400.00] TO BUS 114542 [PAKALDUL 400.00] CKT 1	1429	1429	857	166.77	SC-3
65.	514002 HYDERABAD 400.00 514101 MAHESWRM 400.00 1	OPEN LINE FROM BUS 518051 [MAHESHWARAM 765.00] TO BUS 518079 [WARANGAL NEW765.00] CKT 1	881	861	874	98.46	SC-3
66.	374041 PARLI-PG 400.00 374072 KALLAM 400.00 1	OPEN LINE FROM BUS 374041 [PARLI-PG 400.00] TO BUS 374072 [KALLAM 400.00] CKT 2	861	836	857	97.51	SC-3
67.	174417 RIHAND-G 400.00 174433 RIHAN-HV 400.00 1	OPEN LINE FROM BUS 174417 [RIHAND-G 400.00] TO BUS 174433 [RIHAN-HV 400.00] CKT 2	1515	1515	1600	94.66	SC-3
68.	114597 KWAR 400.00 114598 KIRU 400.00 1	OPEN LINE FROM BUS 114541 [KISTAWAR 400.00] TO BUS 114542 [PAKALDUL 400.00] CKT 1	1020	1020	1093	93.32	SC-3
69.	444010 SAGARDIGHI_4400.00 444019 FARAKKA 400.00 1	OPEN LINE FROM BUS 504885 [ANANTPR2_4 400.00] TO BUS 508885 [ANANTPR2_7 765.00] CKT 1	1008	1008	1093	92.25	SC-3
70.	174424 DADR-NCR 400.00 174454 DADR-HVD 400.00 1	OPEN LINE FROM BUS 174424 [DADR-NCR 400.00] TO BUS 174454 [DADR-HVD 400.00] CKT 2	1465	1465	1600	91.59	SC-3
71.	514002 HYDERABAD 400.00 514101 MAHESWRM 400.00 1	OPEN LINE FROM BUS 518051 [MAHESHWARAM 765.00] TO BUS 518079 [WARANGAL NEW765.00] CKT 1	1773	1814	874	207.51	SC-4

S. No.	Monitored Element	Contingency	Maximum Flow	Flow under Contingency	Rate	% loading	Scenario
72.	114401 BAGLIHAR4 400.00 114476 NEWWANPO 400.00 1	OPEN LINE FROM BUS 114422 [KISHENPUR 400.00] TO BUS 114476 [NEWWANPO 400.00] CKT 1	1601	1601	857	186.84	SC-4
73.	114541 KISTAWAR 400.00 114598 KIRU 400.00 1	OPEN LINE FROM BUS 114541 [KISTAWAR 400.00] TO BUS 114542 [PAKALDUL 400.00] CKT 1	1438	1438	857	167.84	SC-4
74.	504013 KURNOOL4 400.00 504028 KURL-NEW 400.00 1	OPEN LINE FROM BUS 504013 [KURNOOL4 400.00] TO BUS 504028 [KURL-NEW 400.00] CKT 2	1653	1655	1045	158.36	SC-4
75.	144469 BHIWANI-PG 400.00 144480 JINDPG 400.00 1	OPEN LINE FROM BUS 144469 [BHIWANI-PG 400.00] TO BUS 144480 [JINDPG 400.00] CKT 2	1221	1263	857	147.4	SC-4
76.	174438 LUCK4-PG 400.00 174451 LUCK74-P 400.00 1	OPEN LINE FROM BUS 174438 [LUCK4-PG 400.00] TO BUS 174451 [LUCK74-P 400.00] CKT 2	2445	2445	1714	142.66	SC-4
77.	144420 BHIWANI 400.00 144469 BHIWANI-PG 400.00 1	OPEN LINE FROM BUS 144469 [BHIWANI-PG 400.00] TO BUS 144480 [JINDPG 400.00] CKT 1	1175	1215	857	141.8	SC-4
78.	174400 AGRAUP4 400.00 174922 AGRA 400.00 2	OPEN LINE FROM BUS 174414 [AGRANew 400.00] TO BUS 174922 [AGRA 400.00] CKT 2	1204	1204	857	140.45	SC-4
79.	504007 CUDP 400.00 504024 CHITOR 400.00 1	OPEN LINE FROM BUS 544084 [TIRUVLM SE-B400.00] TO BUS 544087 [TIRUVLM SE-A400.00] CKT 1	1160	1183	852	138.84	SC-4
80.	444010 SAGARDIGHI_4400.00 444019 FARAKKA 400.00 1	OPEN LINE FROM BUS 514888 [NIZAMBD2_4 400.00] TO BUS 518888 [NIZAMBD2_7 765.00] CKT 1	1422	1422	1093	130.11	SC-4
81.	504007 CUDP 400.00 504025 ANANTPUR 400.00 1	OPEN LINE FROM BUS 504007 [CUDP 400.00] TO BUS 504025 [ANANTPUR 400.00] CKT 2	2731	2731	2186	124.91	SC-4
82.	504013 KURNOOL4 400.00 514011 SSLBPH4 400.00 1	OPEN LINE FROM BUS 508007 [CUDP800 765.00] TO BUS 508099 [CPETA800 765.00] CKT 1	1286	1289	1045	123.32	SC-4
83.	114422 KISHENPUR 400.00 114476 NEWWANPO 400.00 1	OPEN LINE FROM BUS 114401 [BAGLIHAR4 400.00] TO BUS 114476 [NEWWANPO 400.00] CKT 1	1313	1332	1093	121.85	SC-4

S. No.	Monitored Element	Contingency	Maximum Flow	Flow under Contingency	Rate	% loading	Scenario
84.	444074 PPSP_NEW 400.00 444075 PURULIAPS 400.00 1	OPEN LINE FROM BUS 444074 [PPSP_NEW 400.00] TO BUS 444075 [PURULIAPS 400.00] CKT 2	1041	1032	850	121.36	SC-4
85.	174491 KHURJA TPS 400.00 174512 ALIGARH 400.00 1	OPEN LINE FROM BUS 177265 [GNOIDAUP 765.00] TO BUS 177512 [ALIGARH 765.00] CKT 1	1008	1025	857	119.58	SC-4
86.	314008 SIPAT4 400.00 474048 RNC-SIPT FSC400.00 2	OPEN LINE FROM BUS 474046 [RANCHI 400.00] TO BUS 474049 [RNC-SIPT FSC400.00] CKT 1	1009	992	850	116.74	SC-4
87.	314008 SIPAT4 400.00 474049 RNC-SIPT FSC400.00 1	OPEN LINE FROM BUS 474046 [RANCHI 400.00] TO BUS 474048 [RNC-SIPT FSC400.00] CKT 2	1006	989	850	116.35	SC-4
88.	374014 AURANGBD-I 400.00 374047 AURANGABD-II400.00 1	OPEN LINE FROM BUS 374014 [AURANGBD-I 400.00] TO BUS 374047 [AURANGABD-II400.00] CKT 2	1013	985	857	114.93	SC-4
89.	114422 KISHENPUR 400.00 124401 CHAMERA-2 400.00 1	OPEN LINE FROM BUS 114401 [BAGLIHAR4 400.00] TO BUS 114476 [NEWWANPO 400.00] CKT 1	951	965	857	112.57	SC-4
90.	474046 RANCHI 400.00 474048 RNC-SIPT FSC400.00 2	OPEN LINE FROM BUS 474046 [RANCHI 400.00] TO BUS 474049 [RNC-SIPT FSC400.00] CKT 1	1039	931	850	109.53	SC-4
91.	474046 RANCHI 400.00 474049 RNC-SIPT FSC400.00 1	OPEN LINE FROM BUS 474046 [RANCHI 400.00] TO BUS 474048 [RNC-SIPT FSC400.00] CKT 2	1035	928	850	109.14	SC-4
92.	544086 MALEKTT 400.00 544087 TIRUVLM SE-A400.00 1	OPEN LINE FROM BUS 544086 [MALEKTT 400.00] TO BUS 544087 [TIRUVLM SE-A400.00] CKT 2	905	925	850	108.8	SC-4
93.	174420 ALIGARH-PG 400.00 174491 KHURJA TPS 400.00 1	OPEN LINE FROM BUS 174420 [ALIGARH-PG 400.00] TO BUS 174491 [KHURJA TPS 400.00] CKT 2	919	930	857	108.47	SC-4
94.	174410 BAREL-PG 400.00 174483 BAREILY 400.00 1	OPEN LINE FROM BUS 174410 [BAREL-PG 400.00] TO BUS 174483 [BAREILY 400.00] CKT 2	1853	1849	1714	107.86	SC-4
95.	504026 VIJ-AP 400.00 504037 THALAYAPALEM400.00 1	OPEN LINE FROM BUS 504026 [VIJ-AP 400.00] TO BUS 504037 [THALAYAPALEM400.00] CKT 2	905	917	852	107.59	SC-4

S. No.	Monitored Element	Contingency	Maximum Flow	Flow under Contingency	Rate	% loading	Scenario
96.	174002 BAGPAT 400.00 174905 MEERUT 400.00 1	OPEN LINE FROM BUS 174002 [BAGPAT 400.00] TO BUS 174905 [MEERUT 400.00] CKT 2	911	921	857	107.41	SC-4
97.	174402 BARELI4 400.00 174410 BAREL-PG 400.00 1	OPEN LINE FROM BUS 174402 [BARELI4 400.00] TO BUS 174410 [BAREL-PG 400.00] CKT 2	910	907	857	105.88	SC-4
98.	124001 WANGTOO 400.00 124041 JANGI-THOPAN400.00 1	OPEN LINE FROM BUS 124001 [WANGTOO 400.00] TO BUS 124042 [SHANGTONG 400.00] CKT 1	905	905	857	105.59	SC-4
99.	124401 CHAMERA-2 400.00 124448 CHAM-POL 400.00 1	OPEN LINE FROM BUS 124401 [CHAMERA-2 400.00] TO BUS 124411 [CHAMERA-1 400.00] CKT 1	897	897	857	104.7	SC-4
100.	164400 MERTA 400.00 164434 JODH KANKANI400.00 1	OPEN LINE FROM BUS 167773 [JAIPUR 765.00] TO BUS 167799 [JODH KANKANI765.00] CKT 1	826	885	857	103.26	SC-4
101.	364189 DATIYA NEW4 400.00 364979 MORENA SP 400.00 1	OPEN LINE FROM BUS 364189 [DATIYA NEW4 400.00] TO BUS 364979 [MORENA SP 400.00] CKT 2	2165	2253	2186	103.08	SC-4
102.	154455 MUNDKA 400.00 154463 JHATIKALA-PG400.00 1	OPEN LINE FROM BUS 154455 [MUNDKA 400.00] TO BUS 154463 [JHATIKALA-PG400.00] CKT 2	1942	2036	1988	102.39	SC-4
103.	374002 KHARGAR 400.00 374217 NAVI-MUM 400.00 1	OPEN LINE FROM BUS 374002 [KHARGAR 400.00] TO BUS 374051 [PADGHEGIS 400.00] CKT 1	862	860	857	100.34	SC-4
104.	164404 BHADLA 400.00 164456 BIKANE-4 400.00 1	OPEN LINE FROM BUS 164404 [BHADLA 400.00] TO BUS 164456 [BIKANE-4 400.00] CKT 2	1598	1713	1714	99.95	SC-4
105.	524001 SMNH 400.00 524077 BIDADI 400.00 1	OPEN LINE FROM BUS 524001 [SMNH 400.00] TO BUS 524077 [BIDADI 400.00] CKT 2	829	843	852	98.97	SC-4
106.	164460 FATEHGARH 400.00 164480 FATEHG-2 400.00 1	OPEN LINE FROM BUS 164460 [FATEHGARH 400.00] TO BUS 164480 [FATEHG-2 400.00] CKT 2	2130	2155	2186	98.6	SC-4
107.	164481 FATEHG-3 400.00 164482 FATEHG-4 400.00 1	OPEN LINE FROM BUS 164481 [FATEHG-3 400.00] TO BUS 164482 [FATEHG-4 400.00] CKT 2	2036	2034	2100	96.84	SC-4

S. No.	Monitored Element	Contingency	Maximum Flow	Flow under Contingency	Rate	% loading	Scenario
108.	174414 AGRANEW 400.00 174922 AGRA 400.00 2	OPEN LINE FROM BUS 174400 [AGRAUP4 400.00] TO BUS 174922 [AGRA 400.00] CKT 2	828	828	857	96.59	SC-4
109.	164429 CHIT-NEW 400.00 164492 JALORE 400.00 1	OPEN LINE FROM BUS 164429 [CHIT-NEW 400.00] TO BUS 164492 [JALORE 400.00] CKT 2	823	824	857	96.18	SC-4
110.	364002 BHOPAL-4 400.00 364035 BHOPAL_STER 400.00 1	OPEN LINE FROM BUS 364002 [BHOPAL-4 400.00] TO BUS 364035 [BHOPAL_STER 400.00] CKT 2	2106	2098	2186	96	SC-4
111.	164402 BARMER-4 400.00 164413 RAJWEST 400.00 1	OPEN LINE FROM BUS 164110 [JAISALMER-2 400.00] TO BUS 164434 [JODH KANKANI400.00] CKT 1	793	822	857	95.89	SC-4
112.	174424 DADR-NCR 400.00 174454 DADR-HVD 400.00 1	OPEN LINE FROM BUS 174424 [DADR-NCR 400.00] TO BUS 174454 [DADR-HVD 400.00] CKT 2	1525	1531	1600	95.67	SC-4
113.	114001 LEH_PANG 400.00 114013 PANG400SP3 400.00 1	OPEN LINE FROM BUS 114001 [LEH_PANG 400.00] TO BUS 114013 [PANG400SP3 400.00] CKT 2	1623	1639	1714	95.64	SC-4
114.	124401 CHAMERA-2 400.00 124411 CHAMERA-1 400.00 1	OPEN LINE FROM BUS 124401 [CHAMERA-2 400.00] TO BUS 124448 [CHAM-POL 400.00] CKT 1	820	820	857	95.63	SC-4
115.	114001 LEH_PANG 400.00 114012 PANG400SP2 400.00 1	OPEN LINE FROM BUS 114001 [LEH_PANG 400.00] TO BUS 114012 [PANG400SP2 400.00] CKT 2	1622	1631	1714	95.18	SC-4
116.	164999 DAUSA 400.00 174922 AGRA 400.00 1	OPEN LINE FROM BUS 164999 [DAUSA 400.00] TO BUS 174922 [AGRA 400.00] CKT 2	787	814	857	95.01	SC-4
117.	174451 LUCK74-P 400.00 174484 KANPRNEW 400.00 1	OPEN LINE FROM BUS 174451 [LUCK74-P 400.00] TO BUS 174484 [KANPRNEW 400.00] CKT 2	813	812	857	94.78	SC-4
118.	114001 LEH_PANG 400.00 114008 PANG 400 SP1400.00 1	OPEN LINE FROM BUS 114001 [LEH_PANG 400.00] TO BUS 114008 [PANG 400 SP1400.00] CKT 2	1622	1624	1714	94.74	SC-4
119.	174417 RIHAND-G 400.00 174433 RIHAN-HV 400.00 1	OPEN LINE FROM BUS 174417 [RIHAND-G 400.00] TO BUS 174433 [RIHAN-HV 400.00] CKT 2	1515	1515	1600	94.66	SC-4

S. No.	Monitored Element	Contingency	Maximum Flow	Flow under Contingency	Rate	% loading	Scenario
120.	114597 KWAR 400.00 114598 KIRU 400.00 1	OPEN LINE FROM BUS 114541 [KISTAWAR 400.00] TO BUS 114542 [PAKALDUL 400.00] CKT 1	1027	1027	1093	93.92	SC-4
121.	444074 PPSP_NEW 400.00 474047 RANCHI-NEW 400.00 1	OPEN LINE FROM BUS 444074 [PPSP_NEW 400.00] TO BUS 474047 [RANCHI-NEW 400.00] CKT 2	1045	1026	1093	93.91	SC-4
122.	504005 VIJW 400.00 504030 VIJTP-IV 400.00 1	OPEN LINE FROM BUS 504005 [VIJW 400.00] TO BUS 514004 [KHAMMAM 400.00] CKT 1	819	821	874	93.9	SC-4
123.	174406 NOIIDA-148 400.00 174995 NOIDA-SEC123400.00 1	OPEN LINE FROM BUS 177266 [HAPUR 765.00] TO BUS 177492 [MODIPURAM 765.00] CKT 1	794	801	857	93.47	SC-4
124.	144459 MAHIN_HV 400.00 144669 BHIWANI SR 400.00 1	OPEN LINE FROM BUS 144459 [MAHIN_HV 400.00] TO BUS 144669 [BHIWANI SR 400.00] CKT 2	776	800	857	93.3	SC-4
125.	504007 CUDP 400.00 504998 FSC-3 400.00 1	OPEN LINE FROM BUS 504007 [CUDP 400.00] TO BUS 504999 [FSC-4 400.00] CKT 2	865	883	948	93.16	SC-4
126.	504007 CUDP 400.00 504999 FSC-4 400.00 2	OPEN LINE FROM BUS 504007 [CUDP 400.00] TO BUS 504998 [FSC-3 400.00] CKT 1	865	883	948	93.16	SC-4
127.	504003 NSAGAR 400.00 504998 FSC-3 400.00 1	OPEN LINE FROM BUS 504007 [CUDP 400.00] TO BUS 504999 [FSC-4 400.00] CKT 2	852	883	948	93.16	SC-4
128.	504003 NSAGAR 400.00 504999 FSC-4 400.00 2	OPEN LINE FROM BUS 504007 [CUDP 400.00] TO BUS 504998 [FSC-3 400.00] CKT 1	852	883	948	93.16	SC-4
129.	504026 VIJ-AP 400.00 504045 BURUGUBAN LI400.00 1	OPEN LINE FROM BUS 504026 [VIJ-AP 400.00] TO BUS 504045 [BURUGUBAN LI400.00] CKT 2	804	814	874	93.15	SC-4
130.	144404 JHAJAR_N 400.00 144408 DHANONDA 400.00 1	OPEN LINE FROM BUS 144404 [JHAJAR_N 400.00] TO BUS 144408 [DHANONDA 400.00] CKT 2	776	795	857	92.81	SC-4
131.	524005 HOODI4 400.00 524025 DHANLLI 400.00 1	OPEN LINE FROM BUS 524005 [HOODI4 400.00] TO BUS 524025 [DHANLLI 400.00] CKT 2	777	787	852	92.39	SC-4

S. No.	Monitored Element	Contingency	Maximum Flow	Flow under Contingency	Rate	% loading	Scenario
132	164484 BHADLA-3 400.00 164494 BHADLA-3 HVD400.00 1	OPEN LINE FROM BUS 164484 [BHADLA-3 400.00] TO BUS 164494 [BHADLA-3 HVD400.00] CKT 2	2006	2006	2186	91.78	SC-4
133	514021 DICHPAL4 400.00 514061 NIZAMABAD 400.00 1	OPEN LINE FROM BUS 514021 [DICHPAL4 400.00] TO BUS 514061 [NIZAMABAD 400.00] CKT 2	1996	2003	2186	91.61	SC-4
134	544004 TRICHY 400.00 544017 KARAIK 400.00 1	OPEN LINE FROM BUS 544004 [TRICHY 400.00] TO BUS 544005 [MADURAI4 400.00] CKT 2	777	772	852	90.6	SC-4
135	114541 KISTAWAR 400.00 114598 KIRU 400.00 1	OPEN LINE FROM BUS 114541 [KISTAWAR 400.00] TO BUS 114542 [PAKALDUL 400.00] CKT 1	1981	1981	857	231.1	SC-5
136	114597 KWAR 400.00 114598 KIRU 400.00 1	OPEN LINE FROM BUS 114541 [KISTAWAR 400.00] TO BUS 114542 [PAKALDUL 400.00] CKT 1	1413	1413	1093	129.25	SC-5
137	174000 MEJA 400.00 174474 ALLAHABA 400.00 1	OPEN LINE FROM BUS 174000 [MEJA 400.00] TO BUS 174474 [ALLAHABA 400.00] CKT 2	1025	1025	857	119.65	SC-5
138	114541 KISTAWAR 400.00 114542 PAKALDUL 400.00 1	OPEN LINE FROM BUS 114541 [KISTAWAR 400.00] TO BUS 114598 [KIRU 400.00] CKT 1	1983	1983	1714	115.67	SC-5
139	174400 AGRAUP4 400.00 174922 AGRA 400.00 2	OPEN LINE FROM BUS 174414 [AGRANEW 400.00] TO BUS 174922 [AGRA 400.00] CKT 2	964	971	857	113.24	SC-5
140	174927 GORAKHPU 400.00 814002 BUTWAL 400.00 1	OPEN LINE FROM BUS 174927 [GORAKHPU 400.00] TO BUS 814002 [BUTWAL 400.00] CKT 2	1859	1859	1714	108.44	SC-5
141	114401 BAGLIHAR4 400.00 114476 NEWWANPO 400.00 1	OPEN LINE FROM BUS 114422 [KISHENPUR 400.00] TO BUS 114476 [NEWWANPO 400.00] CKT 1	898	898	857	104.81	SC-5
142	544016 PUGALUR-NEW 400.00 544033 KARUR II 400.00 1	OPEN LINE FROM BUS 544016 [PUGALUR-NEW 400.00] TO BUS 544033 [KARUR II 400.00] CKT 2	2284	2284	2186	104.49	SC-5
143	514002 HYDERABAD 400.00 514101 MAHESWRM 400.00 1	OPEN LINE FROM BUS 518051 [MAHESHWARAM 765.00] TO BUS 518079 [WARANGAL NEW765.00] CKT 1	879	865	874	99.03	SC-5

S. No.	Monitored Element	Contingency	Maximum Flow	Flow under Contingency	Rate	% loading	Scenario
144.	524886 DAVANGR_4 400.00 524888 KOPPAL PS-II400.00 1	OPEN LINE FROM BUS 524886 [DAVANGR_4 400.00] TO BUS 524888 [KOPPAL PS-II400.00] CKT 2	2111	2156	2186	98.65	SC-5
145.	524887 GADAG PS-II 400.00 524888 KOPPAL PS-II400.00 1	OPEN LINE FROM BUS 524887 [GADAG PS-II 400.00] TO BUS 524888 [KOPPAL PS-II400.00] CKT 2	2107	2153	2186	98.47	SC-5
146.	114542 PAKALDUL 400.00 114597 KWAR 400.00 1	OPEN LINE FROM BUS 114541 [KISTAWAR 400.00] TO BUS 114598 [KIRU 400.00] CKT 1	1069	1069	1093	97.78	SC-5
147.	134406 RAJPURA_TH4 400.00 134407 RAJPURA4 400.00 1	OPEN LINE FROM BUS 134406 [RAJPURA_TH4 400.00] TO BUS 134407 [RAJPURA4 400.00] CKT 2	832	834	857	97.37	SC-5
148.	504013 KURNOOL4 400.00 504028 KURL-NEW 400.00 1	OPEN LINE FROM BUS 504013 [KURNOOL4 400.00] TO BUS 504028 [KURL-NEW 400.00] CKT 2	1026	1017	1045	97.35	SC-5
149.	354040 JAM KHAMB PS400.00 354147 LAKADIYA 400.00 1	OPEN LINE FROM BUS 354040 [JAM KHAMB PS400.00] TO BUS 354147 [LAKADIYA 400.00] CKT 3	1338	1604	1650	97.21	SC-5
150.	174417 RIHAND-G 400.00 174433 RIHAN-HV 400.00 1	OPEN LINE FROM BUS 174417 [RIHAND-G 400.00] TO BUS 174433 [RIHAN-HV 400.00] CKT 2	1515	1515	1600	94.66	SC-5
151.	444010 SAGARDIGHI_4400.00 444019 FARAKKA 400.00 1	OPEN LINE FROM BUS 504885 [ANANTPR2_4 400.00] TO BUS 508885 [ANANTPR2_7 765.00] CKT 1	1029	1029	1093	94.18	SC-5
152.	424018 ANGUL-A 400.00 424030 JINDAL-JITPL400.00 1	OPEN LINE FROM BUS 424018 [ANGUL-A 400.00] TO BUS 424030 [JINDAL-JITPL400.00] CKT 2	1017	1017	1093	93.05	SC-5
153.	374004 KARAD4 400.00 374015 JEJ4 400.00 3	OPEN LINE FROM BUS 374015 [JEJ4 400.00] TO BUS 374026 [KOY4-4 400.00] CKT 1	796	788	857	91.89	SC-5
154.	374041 PARLI-PG 400.00 374072 KALLAM 400.00 1	OPEN LINE FROM BUS 374041 [PARLI-PG 400.00] TO BUS 374072 [KALLAM 400.00] CKT 2	799	786	857	91.7	SC-5
155.	174424 DADR-NCR 400.00 174454 DADR-HVD 400.00 1	OPEN LINE FROM BUS 174424 [DADR-NCR 400.00] TO BUS 174454 [DADR-HVD 400.00] CKT 2	1464	1465	1600	91.56	SC-5

S. No.	Monitored Element	Contingency	Maximum Flow	Flow under Contingency	Rate	% loading	Scenario
156.	124467 KALAAMB 400.00 124498 KALAAMBFSC2 400.00 1	OPEN LINE FROM BUS 124001 [WANGTOO 400.00] TO BUS 124468 [KALAAMBFSC 400.00] CKT 1	788	771	850	90.72	SC-5
157.	114541 KISTAWAR 400.00 114598 KIRU 400.00 1	OPEN LINE FROM BUS 114541 [KISTAWAR 400.00] TO BUS 114542 [PAKALDUL 400.00] CKT 1	1473	1473	857	171.93	SC-6
158.	444010 SAGARDIGHI_4400.00 444019 FARAKKA 400.00 1	OPEN LINE FROM BUS 504885 [ANANTPR2_4 400.00] TO BUS 508885 [ANANTPR2_7 765.00] CKT 1	1069	1084	1093	99.22	SC-6
159.	114597 KWAR 400.00 114598 KIRU 400.00 1	OPEN LINE FROM BUS 114541 [KISTAWAR 400.00] TO BUS 114542 [PAKALDUL 400.00] CKT 1	1052	1052	1093	96.21	SC-6
160.	174417 RIHAND-G 400.00 174433 RIHAN-HV 400.00 1	OPEN LINE FROM BUS 174417 [RIHAND-G 400.00] TO BUS 174433 [RIHAN-HV 400.00] CKT 2	1515	1515	1600	94.66	SC-6
161.	174424 DADR-NCR 400.00 174454 DADR-HVD 400.00 1	OPEN LINE FROM BUS 174424 [DADR-NCR 400.00] TO BUS 174454 [DADR-HVD 400.00] CKT 2	1466	1466	1600	91.6	SC-6
162.	544016 PUGALUR-NEW 400.00 544033 KARUR II 400.00 1	OPEN LINE FROM BUS 544016 [PUGALUR-NEW 400.00] TO BUS 544033 [KARUR II 400.00] CKT 2	1995	1995	2186	91.25	SC-6
163.	504013 KURNOOL4 400.00 504028 KURL-NEW 400.00 1	OPEN LINE FROM BUS 504013 [KURNOOL4 400.00] TO BUS 504028 [KURL-NEW 400.00] CKT 2	1575	1571	1045	150.3	SC-7
164.	114401 BAGLIHAR4 400.00 114476 NEWWANPO 400.00 1	OPEN LINE FROM BUS 114422 [KISHENPUR 400.00] TO BUS 114476 [NEWWANPO 400.00] CKT 1	1267	1267	857	147.89	SC-7
165.	504007 CUDP 400.00 504024 CHITOR 400.00 1	OPEN LINE FROM BUS 544084 [TIRUVLM SE-B400.00] TO BUS 544087 [TIRUVLM SE-A400.00] CKT 1	1121	1128	852	132.4	SC-7
166.	374002 KHARGAR 400.00 374217 NAVI-MUM 400.00 1	OPEN LINE FROM BUS 374002 [KHARGAR 400.00] TO BUS 374051 [PADGHEGIS 400.00] CKT 1	1082	1118	857	130.4	SC-7
167.	524001 SMNH 400.00 524077 BIDADI 400.00 1	OPEN LINE FROM BUS 524001 [SMNH 400.00] TO BUS 524077 [BIDADI 400.00] CKT 2	1040	1057	852	124.05	SC-7

S. No.	Monitored Element	Contingency	Maximum Flow	Flow under Contingency	Rate	% loading	Scenario
168.	514002 HYDERABAD 400.00 514101 MAHESWRM 400.00 1	OPEN LINE FROM BUS 514101 [MAHESWRM 400.00] TO BUS 514104 [MAH-TS SEC-A400.00] CKT 1	1062	1056	874	120.8	SC-7
169.	444074 PPSP_NEW 400.00 444075 PURULIAPS 400.00 1	OPEN LINE FROM BUS 444074 [PPSP_NEW 400.00] TO BUS 444075 [PURULIAPS 400.00] CKT 2	1017	1017	850	119.65	SC-7
170.	174438 LUCK4-PG 400.00 174451 LUCK74-P 400.00 1	OPEN LINE FROM BUS 174438 [LUCK4-PG 400.00] TO BUS 174451 [LUCK74-P 400.00] CKT 2	1989	1980	1714	115.53	SC-7
171.	364189 DATIYA NEW4 400.00 364979 MORENA SP 400.00 1	OPEN LINE FROM BUS 364189 [DATIYA NEW4 400.00] TO BUS 364979 [MORENA SP 400.00] CKT 2	2323	2420	2186	110.71	SC-7
172.	444010 SAGARDIGHI_4400.00 444019 FARAKKA 400.00 1	OPEN LINE FROM BUS 514888 [NIZAMBD2_4 400.00] TO BUS 518888 [NIZAMBD2_7 765.00] CKT 1	1198	1198	1093	109.65	SC-7
173.	524005 HOODI4 400.00 524025 DHANLLI 400.00 1	OPEN LINE FROM BUS 524005 [HOODI4 400.00] TO BUS 524025 [DHANLLI 400.00] CKT 2	899	913	852	107.19	SC-7
174.	504005 VIJW 400.00 504030 VIJTP-IV 400.00 1	OPEN LINE FROM BUS 504005 [VIJW 400.00] TO BUS 514004 [KHAMMAM 400.00] CKT 1	925	920	874	105.3	SC-7
175.	504007 CUDP 400.00 504025 ANANTPUR 400.00 1	OPEN LINE FROM BUS 504007 [CUDP 400.00] TO BUS 504025 [ANANTPUR 400.00] CKT 2	2266	2266	2186	103.64	SC-7
176.	544086 MALEKTT 400.00 544087 TIRUVLM SE-A400.00 1	OPEN LINE FROM BUS 544086 [MALEKTT 400.00] TO BUS 544087 [TIRUVLM SE-A400.00] CKT 2	869	875	850	102.89	SC-7
177.	544002 SPBUDUR4 400.00 544090 SVCHTRM 400.00 1	OPEN LINE FROM BUS 544084 [TIRUVLM SE-B400.00] TO BUS 544085 [TIRUVLM SE-C400.00] CKT 1	884	876	852	102.87	SC-7
178.	174000 MEJA 400.00 174474 ALLAHABA 400.00 1	OPEN LINE FROM BUS 174000 [MEJA 400.00] TO BUS 174474 [ALLAHABA 400.00] CKT 2	868	866	857	101.03	SC-7
179.	174424 DADR-NCR 400.00 174454 DADR-HVD 400.00 1	OPEN LINE FROM BUS 174424 [DADR-NCR 400.00] TO BUS 174454 [DADR-HVD 400.00] CKT 2	1593	1593	1600	99.56	SC-7

S. No.	Monitored Element	Contingency	Maximum Flow	Flow under Contingency	Rate	% loading	Scenario
180.	164460 FATEHGARH 400.00 164480 FATEHG-2 400.00 1	OPEN LINE FROM BUS 164460 [FATEHGARH 400.00] TO BUS 164480 [FATEHG-2 400.00] CKT 2	2149	2149	2186	98.29	SC-7
181.	114422 KISHENPUR 400.00 114476 NEWWANPO 400.00 1	OPEN LINE FROM BUS 114401 [BAGLIHAR4 400.00] TO BUS 114476 [NEWWANPO 400.00] CKT 1	1065	1070	1093	97.87	SC-7
182.	164481 FATEHG-3 400.00 164482 FATEHG-4 400.00 1	OPEN LINE FROM BUS 164481 [FATEHG-3 400.00] TO BUS 164482 [FATEHG-4 400.00] CKT 2	2054	2052	2100	97.73	SC-7
183.	114001 LEH_PANG 400.00 114013 PANG400SP3 400.00 1	OPEN LINE FROM BUS 114001 [LEH_PANG 400.00] TO BUS 114013 [PANG400SP3 400.00] CKT 2	1638	1655	1714	96.56	SC-7
184.	114001 LEH_PANG 400.00 114012 PANG400SP2 400.00 1	OPEN LINE FROM BUS 114001 [LEH_PANG 400.00] TO BUS 114012 [PANG400SP2 400.00] CKT 2	1638	1647	1714	96.09	SC-7
185.	114001 LEH_PANG 400.00 114008 PANG 400 SP1400.00 1	OPEN LINE FROM BUS 114001 [LEH_PANG 400.00] TO BUS 114008 [PANG 400 SP1400.00] CKT 2	1637	1639	1714	95.63	SC-7
186.	164429 CHIT-NEW 400.00 164492 JALORE 400.00 1	OPEN LINE FROM BUS 164429 [CHIT-NEW 400.00] TO BUS 164492 [JALORE 400.00] CKT 2	823	817	857	95.3	SC-7
187.	174417 RIHAND-G 400.00 174433 RIHAN-HV 400.00 1	OPEN LINE FROM BUS 174417 [RIHAND-G 400.00] TO BUS 174433 [RIHAN-HV 400.00] CKT 2	1515	1515	1600	94.66	SC-7
188.	504017 VEMAGIR4 400.00 504092 VEMAG-II 400.00 1	OPEN LINE FROM BUS 504017 [VEMAGIR4 400.00] TO BUS 504092 [VEMAG-II 400.00] CKT 2	1021	1010	1093	92.38	SC-7
189.	164484 BHADLA-3 400.00 164494 BHADLA-3 HVD400.00 1	OPEN LINE FROM BUS 164484 [BHADLA-3 400.00] TO BUS 164494 [BHADLA-3 HVD400.00] CKT 2	2004	2004	2186	91.66	SC-7
190.	374074 WARDHA SP 400.00 374099 WARDHA SPLT 400.00 1	OPEN LINE FROM BUS 374074 [WARDHA SP 400.00] TO BUS 374099 [WARDHA SPLT 400.00] CKT 2	1570	1570	1714	91.61	SC-7
191.	374008 DHULE4 400.00 374046 DHULE-STER 400.00 1	OPEN LINE FROM BUS 374008 [DHULE4 400.00] TO BUS 374046 [DHULE-STER 400.00] CKT 2	2002	1983	2186	90.71	SC-7

S. No.	Monitored Element	Contingency	Maximum Flow	Flow under Contingency	Rate	% loading	Scenario
192	114541 KISTAWAR 400.00 114598 KIRU 400.00 1	OPEN LINE FROM BUS 114541 [KISTAWAR 400.00] TO BUS 114542 [PAKALDUL 400.00] CKT 1	1264	1264	857	147.45	SC-8
193	174000 MEJA 400.00 174474 ALLAHABA 400.00 1	OPEN LINE FROM BUS 174000 [MEJA 400.00] TO BUS 174474 [ALLAHABA 400.00] CKT 2	1103	1102	857	128.54	SC-8
194	144401 KHEDAR 400.00 144403 KIRORI 400.00 1	OPEN LINE FROM BUS 144401 [KHEDAR 400.00] TO BUS 144403 [KIRORI 400.00] CKT 2	863	863	857	100.71	SC-8
195	134406 RAJPURA_TH4 400.00 134407 RAJPURA4 400.00 1	OPEN LINE FROM BUS 134406 [RAJPURA_TH4 400.00] TO BUS 134407 [RAJPURA4 400.00] CKT 2	837	837	857	97.62	SC-8
196	504013 KURNOOL4 400.00 504028 KURL-NEW 400.00 1	OPEN LINE FROM BUS 504013 [KURNOOL4 400.00] TO BUS 504028 [KURL-NEW 400.00] CKT 2	1006	995	1045	95.23	SC-8
197	174417 RIHAND-G 400.00 174433 RIHAN-HV 400.00 1	OPEN LINE FROM BUS 174417 [RIHAND-G 400.00] TO BUS 174433 [RIHAN-HV 400.00] CKT 2	1515	1515	1600	94.66	SC-8
198	424050 LAPANGA 400.00 424200 OPGC-OD 400.00 1	OPEN LINE FROM BUS 424050 [LAPANGA 400.00] TO BUS 424200 [OPGC-OD 400.00] CKT 2	1005	1006	1093	91.99	SC-8
199	174424 DADR-NCR 400.00 174454 DADR-HVD 400.00 1	OPEN LINE FROM BUS 174424 [DADR-NCR 400.00] TO BUS 174454 [DADR-HVD 400.00] CKT 2	1454	1454	1600	90.9	SC-8
200	364029 CHEGAON 400.00 364030 MALWA 400.00 1	OPEN LINE FROM BUS 364029 [CHEGAON 400.00] TO BUS 364030 [MALWA 400.00] CKT 2	765	778	857	90.79	SC-8
201	174468 ANPARA4 400.00 174923 SINGRL4 400.00 1	BLOCK TWOTERMDC RIHAH-DADRI1	1192	1192	857	139.12	SC-9
202	504006 GAZW 400.00 504010 GAZU-SR 400.00 1	OPEN LINE FROM BUS 504016 [VIZPOOL 400.00] TO BUS 504098 [HINDJ-OA 400.00] CKT 1	982	982	1000	98.18	SC-9
203	174417 RIHAND-G 400.00 174433 RIHAN-HV 400.00 1	OPEN LINE FROM BUS 174417 [RIHAND-G 400.00] TO BUS 174433 [RIHAN-HV 400.00] CKT 2	1515	1515	1600	94.66	SC-9

S. No.	Monitored Element	Contingency	Maximum Flow	Flow under Contingency	Rate	% loading	Scenario
204.	174424 DADR-NCR 400.00 174454 DADR-HVD 400.00 1	OPEN LINE FROM BUS 174424 [DADR-NCR 400.00] TO BUS 174454 [DADR-HVD 400.00] CKT 2	1494	1494	1600	93.36	SC-9
205.	424018 ANGUL-A 400.00 424030 JINDAL-JITPL400.00 1	OPEN LINE FROM BUS 424018 [ANGUL-A 400.00] TO BUS 424030 [JINDAL-JITPL400.00] CKT 2	986	986	1093	90.2	SC-9

Annex-2.7

N-1 Contingency of 765/400 kV Transformers

S. No.	Monitored Element	Contingency	Base Flow	Maximum Flow	Rate	% loading	Scenario
1.	144469 BHIWANI-PG 400.00 147704 BHIWN-PG 765.00 1	OPEN LINE FROM BUS 144469 [BHIWANI-PG 400.00] TO BUS 147704 [BHIWN-PG 765.00] CKT 3	1055	1410	1000	140.96	SC-1
2.	144469 BHIWANI-PG 400.00 147704 BHIWN-PG 765.00 3	OPEN LINE FROM BUS 144469 [BHIWANI-PG 400.00] TO BUS 147704 [BHIWN-PG 765.00] CKT 1	1583	1901	1500	126.75	SC-1
3.	514101 MAHESWRM 400.00 518051 MAHESHWARAM 765.00 1	OPEN LINE FROM BUS 514101 [MAHESWRM 400.00] TO BUS 518051 [MAHESHWARAM 765.00] CKT 2	1356	1756	1500	117.06	SC-1
4.	144669 BHIWANI SR 400.00 147704 BHIWN-PG 765.00 2	OPEN LINE FROM BUS 144669 [BHIWANI-PG 400.00] TO BUS 147704 [BHIWN-PG 765.00] CKT 3	936	1126	1000	112.6	SC-1
5.	504099 CPETA400 400.00 508099 CPETA800 765.00 1	OPEN LINE FROM BUS 504099 [CPETA400 400.00] TO BUS 508099 [CPETA800 765.00] CKT 2	1080	1642	1500	109.49	SC-1
6.	374043 AURANG-CHTPM400.00 378043 AURANG-CHTPM765.00 1	OPEN LINE FROM BUS 374043 [AURANG-CHTPM400.00] TO BUS 378043 [AURANG-CHTPM765.00] CKT 2	1137	1612	1500	107.48	SC-1
7.	354129 MUL 400.00 358129 MUL 765 765.00 3	OPEN LINE FROM BUS 354129 [MUL 400.00] TO BUS 358129 [MUL 765 765.00] CKT 4	1048	1595	1500	106.35	SC-1
8.	514061 NIZAMABAD 400.00 518062 NIZAMABAD 765.00 1	OPEN LINE FROM BUS 514061 [NIZAMABAD 400.00] TO BUS 518062 [NIZAMABAD 765.00] CKT 2	1262	1578	1500	105.21	SC-1
9.	314008 SIPAT4 400.00 318007 SIPAT 765.00 1	OPEN LINE FROM BUS 314008 [SIPAT4 400.00] TO BUS 318007 [SIPAT 765.00] CKT 2	681	1033	1000	103.29	SC-1
10.	514078 WARANGAL NEW400.00 518079 WARANGAL NEW765.00 1	OPEN LINE FROM BUS 514078 [WARANGAL NEW400.00] TO BUS 518079 [WARANGAL NEW765.00] CKT 2	968	1527	1500	101.81	SC-1

S. No.	Monitored Element	Contingency	Base Flow	Maximum Flow	Rate	% loading	Scenario
11.	504049 KURNOOL-III 400.00 508049 KURNOOL-III 765.00 1	OPEN LINE FROM BUS 504049 [KURNOOL-III 400.00] TO BUS 508049 [KURNOOL-III 765.00] CKT 2	1285	1527	1500	101.77	SC-1
12.	154463 JHATIKALA-PG400.00 157708 JHATI-PG 765.00 2	OPEN LINE FROM BUS 154463 [JHATIKALA-PG400.00] TO BUS 157708 [JHATI-PG 765.00] CKT 1	1013	1515	1500	100.98	SC-1
13.	544127 ARIYALUR4 400.00 548127 ARIYALUR7 765.00 1	OPEN LINE FROM BUS 544127 [ARIYALUR4 400.00] TO BUS 548127 [ARIYALUR7 765.00] CKT 2	971	1492	1500	99.5	SC-1
14.	424091 JHARSUGUDA-B400.00 428091 JHARSUGUDA-B765.00 3	OPEN LINE FROM BUS 424091 [JHARSUGUDA-B400.00] TO BUS 428091 [JHARSUGUDA-B765.00] CKT 4	952	1491	1500	99.4	SC-1
15.	164498 BHADLA-2 400.00 167498 BHADLA-2 765.00 1	OPEN LINE FROM BUS 164498 [BHADLA-2 400.00] TO BUS 167498 [BHADLA-2 765.00] CKT 2	1215	1459	1500	97.26	SC-1
16.	164484 BHADLA-3 400.00 167484 BHADLA-3 765.00 1	BLOCK TWOTERMDC BHADL-FATEH1	757	1459	1500	97.25	SC-1
17.	174990 FATEH VSC 400.00 177990 FATEHPUR 765765.00 1	OPEN LINE FROM BUS 174990 [FATEH VSC 400.00] TO BUS 177990 [FATEHPUR 765765.00] CKT 2	1162	1452	1500	96.83	SC-1
18.	174483 BAREILY 400.00 177806 BAREILLY 765.00 1	OPEN LINE FROM BUS 174483 [BAREILY 400.00] TO BUS 177806 [BAREILLY 765.00] CKT 2	936	1440	1500	95.98	SC-1
19.	314030 RAIPUR_POOL 400.00 318030 RAIPUR_POOL 765.00 1	OPEN LINE FROM BUS 314030 [RAIPUR_POOL 400.00] TO BUS 318030 [RAIPUR_POOL 765.00] CKT 2	901	1431	1500	95.42	SC-1
20.	164999 DAUSA 400.00 167999 DAUSA 765.00 1	OPEN LINE FROM BUS 164999 [DAUSA 400.00] TO BUS 167999 [DAUSA 765.00] CKT 2	850	1418	1500	94.54	SC-1
21.	504092 VEMAG-II 400.00 508092 VEM-II80 765.00 1	OPEN LINE FROM BUS 504092 [VEMAG-II 400.00] TO BUS 508092 [VEM-II80 765.00] CKT 2	902	1407	1500	93.77	SC-1
22.	154501 NARELA ISTS 400.00 157001 NARELA ISTS 765.00 1	OPEN LINE FROM BUS 154501 [NARELA ISTS 400.00] TO BUS 157001 [NARELA ISTS 765.00] CKT 2	1070	1401	1500	93.4	SC-1

S. No.	Monitored Element	Contingency	Base Flow	Maximum Flow	Rate	% loading	Scenario
23.	164497 SIKAR NEW 400.00 167497 SIKAR NEW 765.00 1	OPEN LINE FROM BUS 164497 [SIKAR NEW 400.00] TO BUS 167497 [SIKAR NEW 765.00] CKT 2	842	1396	1500	93.1	SC-1
24.	164422 RAMG-I 400.00 167422 RAMGARH-I 765.00 1	OPEN LINE FROM BUS 164422 [RAMG-I 400.00] TO BUS 167422 [RAMGARH-I 765.00] CKT 2	911	1369	1500	91.27	SC-1
25.	354129 MUL 400.00 358129 MUL 765 765.00 3	OPEN LINE FROM BUS 354129 [MUL 400.00] TO BUS 358129 [MUL 765 765.00] CKT 4	1047	1593	1500	106.17	SC-2
26.	174258 ORAI 400.00 177258 ORAI 765.00 1	OPEN LINE FROM BUS 174258 [ORAI 400.00] TO BUS 177258 [ORAI 765.00] CKT 2	661	951	1000	95.08	SC-2
27.	544127 ARIYALUR4 400.00 548127 ARIYALUR7 765.00 1	OPEN LINE FROM BUS 544127 [ARIYALUR4 400.00] TO BUS 548127 [ARIYALUR7 765.00] CKT 2	910	1402	1500	93.48	SC-2
28.	144469 BHIWANI-PG 400.00 147704 BHIWN-PG 765.00 1	OPEN LINE FROM BUS 144469 [BHIWANI-PG 400.00] TO BUS 147704 [BHIWN-PG 765.00] CKT 3	1137	1520	1000	151.97	SC-4
29.	144469 BHIWANI-PG 400.00 147704 BHIWN-PG 765.00 3	OPEN LINE FROM BUS 144469 [BHIWANI-PG 400.00] TO BUS 147704 [BHIWN-PG 765.00] CKT 1	1705	2049	1500	136.63	SC-4
30.	314008 SIPAT4 400.00 318007 SIPAT 765.00 1	OPEN LINE FROM BUS 314008 [SIPAT4 400.00] TO BUS 318007 [SIPAT 765.00] CKT 2	820	1242	1000	124.16	SC-4
31.	144669 BHIWANI SR 400.00 147704 BHIWN-PG 765.00 2	OPEN LINE FROM BUS 144469 [BHIWANI-PG 400.00] TO BUS 147704 [BHIWN-PG 765.00] CKT 3	1035	1236	1000	123.55	SC-4
32.	174479 VARANASI 400.00 177000 VARNASI8 765.00 1	OPEN LINE FROM BUS 174479 [VARANASI 400.00] TO BUS 177000 [VARNASI8 765.00] CKT 2	1197	1711	1500	114.09	SC-4
33.	514101 MAHESWRM 400.00 518051 MAHESHWARAM 765.00 1	OPEN LINE FROM BUS 514101 [MAHESWRM 400.00] TO BUS 518051 [MAHESHWARAM 765.00] CKT 2	1295	1678	1500	111.88	SC-4
34.	164999 DAUSA 400.00 167999 DAUSA 765.00 1	OPEN LINE FROM BUS 164999 [DAUSA 400.00] TO BUS 167999 [DAUSA 765.00] CKT 2	1002	1672	1500	111.46	SC-4

S. No.	Monitored Element	Contingency	Base Flow	Maximum Flow	Rate	% loading	Scenario
35.	174483 BAREILY 400.00 177806 BAREILLY 765.00 1	OPEN LINE FROM BUS 174483 [BAREILY 400.00] TO BUS 177806 [BAREILLY 765.00] CKT 2	1070	1644	1500	109.62	SC-4
36.	424091 JHARSUGUDA-B400.00 428091 JHARSUGUDA-B765.00 3	OPEN LINE FROM BUS 424091 [JHARSUGUDA-B400.00] TO BUS 428091 [JHARSUGUDA-B765.00] CKT 4	1040	1631	1500	108.71	SC-4
37.	504049 KURNOOL-III 400.00 508049 KURNOOL-III 765.00 1	OPEN LINE FROM BUS 504049 [KURNOOL-III 400.00] TO BUS 508049 [KURNOOL-III 765.00] CKT 2	1351	1605	1500	107.03	SC-4
38.	154463 JHATIKALA-PG400.00 157708 JHATI-PG 765.00 2	OPEN LINE FROM BUS 154463 [JHATIKALA-PG400.00] TO BUS 157708 [JHATI-PG 765.00] CKT 1	1066	1597	1500	106.46	SC-4
39.	354129 MUL 400.00 358129 MUL 765 765.00 3	OPEN LINE FROM BUS 354129 [MUL 400.00] TO BUS 358129 [MUL 765 765.00] CKT 4	1048	1594	1500	106.3	SC-4
40.	164484 BHADLA-3 400.00 167484 BHADLA-3 765.00 1	OPEN LINE FROM BUS 164484 [BHADLA-3 400.00] TO BUS 167484 [BHADLA-3 765.00] CKT 2	929	1552	1500	103.49	SC-4
41.	504099 CPETA400 400.00 508099 CPETA800 765.00 1	OPEN LINE FROM BUS 504099 [CPETA400 400.00] TO BUS 508099 [CPETA800 765.00] CKT 2	1006	1533	1500	102.2	SC-4
42.	164498 BHADLA-2 400.00 167498 BHADLA-2 765.00 1	OPEN LINE FROM BUS 164498 [BHADLA-2 400.00] TO BUS 167498 [BHADLA-2 765.00] CKT 2	1270	1526	1500	101.71	SC-4
43.	154501 NARELA ISTS 400.00 157001 NARELA ISTS 765.00 1	OPEN LINE FROM BUS 154501 [NARELA ISTS 400.00] TO BUS 157001 [NARELA ISTS 765.00] CKT 2	1157	1516	1500	101.05	SC-4
44.	424017 PARADEEP 400.00 428017 PARADEEP 765.00 2	OPEN LINE FROM BUS 424017 [PARADEEP 400.00] TO BUS 428017 [PARADEEP 765.00] CKT 3	1029	1478	1500	98.56	SC-4
45.	164497 SIKAR NEW 400.00 167497 SIKAR NEW 765.00 1	OPEN LINE FROM BUS 164497 [SIKAR NEW 400.00] TO BUS 167497 [SIKAR NEW 765.00] CKT 2	879	1467	1500	97.78	SC-4
46.	174990 FATEH VSC 400.00 177990 FATEHPUR 765765.00 1	OPEN LINE FROM BUS 174990 [FATEH VSC 400.00] TO BUS 177990 [FATEHPUR 765765.00] CKT 2	1158	1448	1500	96.56	SC-4

S. No.	Monitored Element	Contingency	Base Flow	Maximum Flow	Rate	% loading	Scenario
47.	164422 RAMG-I 400.00 167422 RAMGARH-I 765.00 1	OPEN LINE FROM BUS 164422 [RAMG-I 400.00] TO BUS 167422 [RAMGARH-I 765.00] CKT 2	954	1436	1500	95.76	SC-4
48.	514061 NIZAMABAD 400.00 518062 NIZAMABAD 765.00 1	OPEN LINE FROM BUS 514061 [NIZAMABAD 400.00] TO BUS 518062 [NIZAMABAD 765.00] CKT 2	1138	1426	1500	95.05	SC-4
49.	444090 JEERAT-NEW 400.00 448008 JEERAT7 765.00 1	OPEN LINE FROM BUS 444090 [JEERAT-NEW 400.00] TO BUS 448008 [JEERAT7 765.00] CKT 2	863	1422	1500	94.77	SC-4
50.	364189 DATIYA NEW4 400.00 368089 DATIA NEW 7 765.00 1	OPEN LINE FROM BUS 364189 [DATIYA NEW4 400.00] TO BUS 368089 [DATIA NEW 7 765.00] CKT 2	784	1420	1500	94.68	SC-4
51.	524888 KOPPAL PS-II400.00 528888 KOPPAL PS-II765.00 1	OPEN LINE FROM BUS 524888 [KOPPAL PS-II400.00] TO BUS 528888 [KOPPAL PS-II765.00] CKT 2	1178	1415	1500	94.36	SC-4
52.	374043 AURANG-CHTPM400.00 378043 AURANG-CHTPM765.00 1	OPEN LINE FROM BUS 374043 [AURANG-CHTPM400.00] TO BUS 378043 [AURANG-CHTPM765.00] CKT 2	971	1376	1500	91.72	SC-4
53.	164480 FATEHG-2 400.00 167480 FATEH-2 765.00 1	OPEN LINE FROM BUS 164480 [FATEHG-2 400.00] TO BUS 167480 [FATEH-2 765.00] CKT 2	1193	1374	1500	91.61	SC-4
54.	354129 MUL 400.00 358129 MUL 765 765.00 3	OPEN LINE FROM BUS 354129 [MUL 400.00] TO BUS 358129 [MUL 765 765.00] CKT 4	1047	1593	1500	106.18	SC-5
55.	174258 ORAI 400.00 177258 ORAI 765.00 1	OPEN LINE FROM BUS 174258 [ORAI 400.00] TO BUS 177258 [ORAI 765.00] CKT 2	679	977	1000	97.66	SC-5
56.	364012 SATNA-74 400.00 368012 SATNA-7 765.00 1	OPEN LINE FROM BUS 364012 [SATNA-74 400.00] TO BUS 368012 [SATNA-7 765.00] CKT 2	661	959	1000	95.9	SC-5
57.	424017 PARADEEP 400.00 428017 PARADEEP 765.00 1	OPEN LINE FROM BUS 424017 [PARADEEP 400.00] TO BUS 428017 [PARADEEP 765.00] CKT 2	939	1353	1500	90.18	SC-5
58.	364023 INDORE-74 400.00 368023 INDORE-7 765.00 2	OPEN LINE FROM BUS 364799 [INDOR-SPLT 400.00] TO BUS 368023 [INDORE-7 765.00] CKT 1	1423	1708	1500	113.86	SC-7

S. No.	Monitored Element	Contingency	Base Flow	Maximum Flow	Rate	% loading	Scenario
59.	544127 ARIYALUR4 400.00 548127 ARIYALUR7 765.00 1	OPEN LINE FROM BUS 544127 [ARIYALUR4 400.00] TO BUS 548127 [ARIYALUR7 765.00] CKT 2	1108	1704	1500	113.61	SC-7
60.	544128 COIMBTR4 400.00 548128 COIMBTR7 765.00 1	OPEN LINE FROM BUS 544128 [COIMBTR4 400.00] TO BUS 548128 [COIMBTR7 765.00] CKT 2	1070	1683	1500	112.22	SC-7
61.	354129 MUL 400.00 358129 MUL 765 765.00 3	OPEN LINE FROM BUS 354129 [MUL 400.00] TO BUS 358129 [MUL 765 765.00] CKT 4	1048	1595	1500	106.31	SC-7
62.	374043 AURANG-CHTPM400.00 378043 AURANG-CHTPM765.00 1	OPEN LINE FROM BUS 374043 [AURANG-CHTPM400.00] TO BUS 378043 [AURANG-CHTPM765.00] CKT 2	1105	1568	1500	104.56	SC-7
63.	424091 JHARSUGUDA-B400.00 428091 JHARSUGUDA-B765.00 3	OPEN LINE FROM BUS 424091 [JHARSUGUDA-B400.00] TO BUS 428091 [JHARSUGUDA-B765.00] CKT 4	952	1491	1500	99.38	SC-7
64.	364799 INDOR-SPLT 400.00 368023 INDORE-7 765.00 1	OPEN LINE FROM BUS 364023 [INDORE-74 400.00] TO BUS 368023 [INDORE-7 765.00] CKT 2	1128	1461	1500	97.38	SC-7
65.	174990 FATEH VSC 400.00 177990 FATEHPUR 765765.00 1	OPEN LINE FROM BUS 174990 [FATEH VSC 400.00] TO BUS 177990 [FATEHPUR 765765.00] CKT 2	1161	1451	1500	96.73	SC-7
66.	164498 BHADLA-2 400.00 167498 BHADLA-2 765.00 1	OPEN LINE FROM BUS 164498 [BHADLA-2 400.00] TO BUS 167498 [BHADLA-2 765.00] CKT 2	1197	1437	1500	95.81	SC-7
67.	164422 RAMG-I 400.00 167422 RAMGARH-I 765.00 1	OPEN LINE FROM BUS 164422 [RAMG-I 400.00] TO BUS 167422 [RAMGARH-I 765.00] CKT 2	947	1426	1500	95.04	SC-7
68.	144469 BHIWANI-PG 400.00 147704 BHIWN-PG 765.00 1	OPEN LINE FROM BUS 144469 [BHIWANI-PG 400.00] TO BUS 147704 [BHIWN-PG 765.00] CKT 3	698	932	1000	93.17	SC-7
69.	514101 MAHESWRM 400.00 518051 MAHESHWARAM 765.00 1	OPEN LINE FROM BUS 514101 [MAHESWRM 400.00] TO BUS 518051 [MAHESHWARAM 765.00] CKT 2	1070	1387	1500	92.44	SC-7
70.	164481 FATEHG-3 400.00 167481 FATEHG-3 765.00 1	OPEN LINE FROM BUS 164481 [FATEHG-3 400.00] TO BUS 167481 [FATEHG-3 765.00] CKT 2	1158	1354	1500	90.26	SC-7

S. No.	Monitored Element	Contingency	Base Flow	Maximum Flow	Rate	% loading	Scenario
71.	354129 MUL 400.00 358129 MUL 765 765.00 3	OPEN LINE FROM BUS 354129 [MUL 400.00] TO BUS 358129 [MUL 765 765.00] CKT 4	1047	1593	1500	106.19	SC-8

N-1 Contingency of 400/220 kV Transformers

S. No.	Monitored Element	Contingency	Base Flow	Maximum Flow	Rate	% loading	Scenario
1.	114422 KISHENPUR 400.00 112235 KISHENPUR 220.00 1	OPEN LINE FROM BUS 114422 [KISHENPUR 400.00] TO BUS 112235 [KISHENPUR 220.00] CKT 2	528	661	315	209.81	SC-1
2.	164422 RAMG-I 400.00 162422 RAMGARH-I 220.00 1	OPEN LINE FROM BUS 164422 [RAMG-I 400.00] TO BUS 162422 [RAMGARH-I 220.00] CKT 2	424	852	500	170.44	SC-1
3.	164459 BHADLA PG 400.00 162659 BHADLA-SPLT 220.00 1	OPEN LINE FROM BUS 164459 [BHADLA PG 400.00] TO BUS 162659 [BHADLA-SPLT 220.00] CKT 2	347	694	500	138.85	SC-1
4.	164498 BHADLA-2 400.00 162499 BHAD-2 SPLT 220.00 1	OPEN LINE FROM BUS 164498 [BHADLA-2 400.00] TO BUS 162499 [BHAD-2 SPLT 220.00] CKT 2	446	671	500	134.16	SC-1
5.	324002 MAGARWADA-DD400.00 322002 MAGARWADA 220.00 1	OPEN LINE FROM BUS 324002 [MAGARWADA-DD400.00] TO BUS 322002 [MAGARWADA 220.00] CKT 2	206	420	315	133.32	SC-1
6.	374028 NAGOTHANE 400.00 372150 NAGOTHA2 220.00 1	OPEN LINE FROM BUS 374028 [NAGOTHANE 400.00] TO BUS 372150 [NAGOTHA2 220.00] CKT 2	262	408	315	129.42	SC-1
7.	444012 KOLAGHAT 400.00 442012 KTPS220 220.00 1	OPEN LINE FROM BUS 444012 [KOLAGHAT 400.00] TO BUS 442012 [KTPS220 220.00] CKT 2	275	407	315	129.24	SC-1
8.	504007 CUDP 400.00 502216 CHINAKAMPALL220.00 1	OPEN LINE FROM BUS 504007 [CUDP 400.00] TO BUS 502216 [CHINAKAMPALL220.00] CKT 3	287	395	315	125.3	SC-1
9.	374099 WARDHA SPLT 400.00 372071 WARDH_PG 220.00 2	OPEN LINE FROM BUS 374099 [WARDHA SPLT 400.00] TO BUS 372071 [WARDH_PG 220.00] CKT 4	273	384	315	121.89	SC-1
10.	164415 DEEDWANA 400.00 162093 DEEDWANA-42 220.00 1	OPEN LINE FROM BUS 164415 [DEEDWANA 400.00] TO BUS 162093 [DEEDWANA-42 220.00] CKT 2	247	372	315	118.07	SC-1
11.	164420 KOTA 400.00 162919 KOTA 220.00 1	OPEN LINE FROM BUS 164420 [KOTA 400.00] TO BUS 162919 [KOTA 220.00] CKT 2	285	367	315	116.4	SC-1

S. No.	Monitored Element	Contingency	Base Flow	Maximum Flow	Rate	% loading	Scenario
12.	164498 BHADLA-2 400.00 162498 BHADLA-2 220.00 1	OPEN LINE FROM BUS 164498 [BHADLA-2 400.00] TO BUS 162498 [BHADLA-2 220.00] CKT 2	458	573	500	114.69	SC-1
13.	164481 FATEHG-3 400.00 162481 FATEHG-3 220.00 1	OPEN LINE FROM BUS 164481 [FATEHG-3 400.00] TO BUS 162481 [FATEHG-3 220.00] CKT 2	456	571	500	114.2	SC-1
14.	544132 KAMUTHI4 400.00 542130 KAMUDHI42 230.00 1	OPEN LINE FROM BUS 544132 [KAMUTHI4 400.00] TO BUS 542130 [KAMUDHI42 230.00] CKT 2	178	356	315	112.95	SC-1
15.	164428 CHITTOR4 400.00 162228 CHITTOR-42 220.00 1	OPEN LINE FROM BUS 164428 [CHITTOR4 400.00] TO BUS 162228 [CHITTOR-42 220.00] CKT 2	271	352	315	111.73	SC-1
16.	164409 HINDAU-4 400.00 162207 HINDAU-4 220.00 1	OPEN LINE FROM BUS 164409 [HINDAU-4 400.00] TO BUS 162207 [HINDAU-4 220.00] CKT 2	235	347	315	110.22	SC-1
17.	504007 CUDP 400.00 502216 CHINAKAMPALL220.00 3	OPEN LINE FROM BUS 504007 [CUDP 400.00] TO BUS 502216 [CHINAKAMPALL220.00] CKT 1	456	550	500	110.08	SC-1
18.	424014 DUBURI 400.00 422564 DUBRI NEW 220.00 1	OPEN LINE FROM BUS 424014 [DUBURI 400.00] TO BUS 422564 [DUBRI NEW 220.00] CKT 2	252	346	315	109.97	SC-1
19.	164404 BHADLA 400.00 162285 BHADLA-S 220.00 1	OPEN LINE FROM BUS 164404 [BHADLA 400.00] TO BUS 162285 [BHADLA-S 220.00] CKT 2	429	545	500	109.05	SC-1
20.	134322 ROPAR4 400.00 132322 ROPAR42 220.00 1	OPEN LINE FROM BUS 134322 [ROPAR4 400.00] TO BUS 132322 [ROPAR42 220.00] CKT 2	380	536	500	107.28	SC-1
21.	374028 NAGOTHANE 400.00 372150 NAGOTHA2 220.00 2	OPEN LINE FROM BUS 374028 [NAGOTHANE 400.00] TO BUS 372150 [NAGOTHA2 220.00] CKT 1	415	536	500	107.11	SC-1
22.	374099 WARDHA SPLT 400.00 372071 WARDH_PG 220.00 4	OPEN LINE FROM BUS 374099 [WARDHA SPLT 400.00] TO BUS 372071 [WARDH_PG 220.00] CKT 2	435	532	500	106.5	SC-1
23.	164459 BHADLA PG 400.00 162359 BHADLA-PG 220.00 1	OPEN LINE FROM BUS 164459 [BHADLA PG 400.00] TO BUS 162359 [BHADLA-PG 220.00] CKT 2	443	532	500	106.4	SC-1

S. No.	Monitored Element	Contingency	Base Flow	Maximum Flow	Rate	% loading	Scenario
24.	364189 DATIYA NEW4 400.00 362189 DATIYA NEW2 220.00 1	OPEN LINE FROM BUS 364189 [DATIYA NEW4 400.00] TO BUS 362189 [DATIYA NEW2 220.00] CKT 2	340	532	500	106.33	SC-1
25.	164484 BHADLA-3 400.00 162484 BHADLA-3 220.00 1	OPEN LINE FROM BUS 164484 [BHADLA-3 400.00] TO BUS 162484 [BHADLA-3 220.00] CKT 2	424	531	500	106.15	SC-1
26.	164484 BHADLA-3 400.00 163484 BHADLA3-SPL 220.00 1	OPEN LINE FROM BUS 164484 [BHADLA-3 400.00] TO BUS 163484 [BHADLA3-SPL 220.00] CKT 2	424	531	500	106.15	SC-1
27.	134484 PATRAN4 400.00 132241 PATRAN42 220.00 1	OPEN LINE FROM BUS 134484 [PATRAN4 400.00] TO BUS 132241 [PATRAN42 220.00] CKT 2	412	530	500	106.07	SC-1
28.	164406 HERAPU-4 400.00 162211 HIRAPURA 220.00 2	OPEN LINE FROM BUS 164406 [HERAPU-4 400.00] TO BUS 162211 [HIRAPURA 220.00] CKT 1	227	265	250	106.02	SC-1
29.	444015 CHANDITALA_N400.00 442015 CHANDITALA_N220.00 1	OPEN LINE FROM BUS 444015 [CHANDITALA_N400.00] TO BUS 442015 [CHANDITALA_N220.00] CKT 2	273	333	315	105.84	SC-1
30.	444018 KHARAGPR-WB 400.00 442018 KHARAGPR-WB 220.00 1	OPEN LINE FROM BUS 444018 [KHARAGPR-WB 400.00] TO BUS 442018 [KHARAGPR-WB 220.00] CKT 2	242	333	315	105.78	SC-1
31.	164431 BASSI 400.00 162283 BASSI 220.00 1	OPEN LINE FROM BUS 164431 [BASSI 400.00] TO BUS 162283 [BASSI 220.00] CKT 3	246	330	315	104.92	SC-1
32.	174431 KANPUR 400.00 172103 KANPU-PG 220.00 1	OPEN LINE FROM BUS 174431 [KANPUR 400.00] TO BUS 172103 [KANPU-PG 220.00] CKT 2	258	327	315	103.87	SC-1
33.	524050 JAGALUR4 400.00 522158 JAGALUR2 220.00 1	OPEN LINE FROM BUS 524050 [JAGALUR4 400.00] TO BUS 522158 [JAGALUR2 220.00] CKT 2	339	518	500	103.56	SC-1
34.	164405 BHINMAL 400.00 162914 BHINM-PG 220.00 1	OPEN LINE FROM BUS 164405 [BHINMAL 400.00] TO BUS 162914 [BHINM-PG 220.00] CKT 2	239	324	315	102.94	SC-1
35.	164406 HERAPU-4 400.00 162211 HIRAPURA 220.00 1	OPEN LINE FROM BUS 164406 [HERAPU-4 400.00] TO BUS 162211 [HIRAPURA 220.00] CKT 2	286	323	315	102.45	SC-1

S. No.	Monitored Element	Contingency	Base Flow	Maximum Flow	Rate	% loading	Scenario
36.	124419 DEHAR 400.00 122218 DEHAR 220.00 1	OPEN LINE FROM BUS 124419 [DEHAR 400.00] TO BUS 134407 [RAJPURA4 400.00] CKT 1	252	322	315	102.3	SC-1
37.	114013 PANG400SP3 400.00 114011 PANG220SP3 220.00 1	OPEN LINE FROM BUS 114013 [PANG400SP3 400.00] TO BUS 114011 [PANG220SP3 220.00] CKT 2	263	316	315	100.45	SC-1
38.	114012 PANG400SP2 400.00 114010 PANG220SP2 220.00 1	OPEN LINE FROM BUS 114012 [PANG400SP2 400.00] TO BUS 114010 [PANG220SP2 220.00] CKT 2	263	316	315	100.44	SC-1
39.	114008 PANG 400 SP1400.00 114009 LEH_PANG SP 220.00 1	OPEN LINE FROM BUS 114008 [PANG 400 SP1400.00] TO BUS 114009 [LEH_PANG SP 220.00] CKT 2	263	316	315	100.43	SC-1
40.	154497 DWARKA 400.00 152287 DWARKA-II 220.00 3	OPEN LINE FROM BUS 154497 [DWARKA 400.00] TO BUS 152287 [DWARKA-II 220.00] CKT 4	366	502	500	100.43	SC-1
41.	164416 AJMER 400.00 162329 AJMER42 220.00 1	OPEN LINE FROM BUS 164416 [AJMER 400.00] TO BUS 162329 [AJMER42 220.00] CKT 2	225	315	315	99.98	SC-1
42.	544026 KANAPATT 400.00 542148 KANARP42 230.00 1	OPEN LINE FROM BUS 544026 [KANAPATT 400.00] TO BUS 542148 [KANARP42 230.00] CKT 2	157	314	315	99.77	SC-1
43.	164482 FATEHG-4 400.00 162482 FATEHG-4 220.00 1	OPEN LINE FROM BUS 164482 [FATEHG-4 400.00] TO BUS 162482 [FATEHG-4 220.00] CKT 2	396	496	500	99.11	SC-1
44.	454002 MEJIA-B 400.00 452002 MEJIA-B 220.00 1	OPEN LINE FROM BUS 454002 [MEJIA-B 400.00] TO BUS 452002 [MEJIA-B 220.00] CKT 2	228	310	315	98.29	SC-1
45.	514104 MAH-TS SEC-A400.00 512082 MAHESH-TS2 220.00 1	OPEN LINE FROM BUS 514104 [MAH-TS SEC-A400.00] TO BUS 512082 [MAHESH-TS2 220.00] CKT 2	388	491	500	98.17	SC-1
46.	134925 MALERKOTLA4 400.00 132911 MALERKOTLA42220.00 1	OPEN LINE FROM BUS 134925 [MALERKOTLA4 400.00] TO BUS 132911 [MALERKOTLA42220.00] CKT 3	233	309	315	97.98	SC-1
47.	134442 PATIALA4 400.00 132942 PATIALA42 220.00 1	OPEN LINE FROM BUS 134442 [PATIALA4 400.00] TO BUS 132942 [PATIALA42 220.00] CKT 3	251	307	315	97.59	SC-1

S. No.	Monitored Element	Contingency	Base Flow	Maximum Flow	Rate	% loading	Scenario
48.	134442 PATIALA4 400.00 132942 PATIALA42 220.00 3	OPEN LINE FROM BUS 134442 [PATIALA4 400.00] TO BUS 132942 [PATIALA42 220.00] CKT 4	397	487	500	97.39	SC-1
49.	534952 EDAMAN4 400.00 532003 EDAMON2 220.00 2	OPEN LINE FROM BUS 534952 [EDAMAN4 400.00] TO BUS 532003 [EDAMON2 220.00] CKT 1	223	302	315	95.9	SC-1
50.	124404 NALLAGAR 400.00 122904 NALLAGAR 220.00 1	OPEN LINE FROM BUS 124404 [NALLAGAR 400.00] TO BUS 122904 [NALLAGAR 220.00] CKT 2	241	302	315	95.79	SC-1
51.	354012 SUGEN 400.00 352012 SUGEN 220.00 1	OPEN LINE FROM BUS 354012 [SUGEN 400.00] TO BUS 352012 [SUGEN 220.00] CKT 2	244	301	315	95.64	SC-1
52.	504003 NSAGAR 400.00 502271 TALLAPALLI 220.00 1	OPEN LINE FROM BUS 504003 [NSAGAR 400.00] TO BUS 502271 [TALLAPALLI 220.00] CKT 2	252	301	315	95.55	SC-1
53.	374217 NAVI-MUM 400.00 372365 NAVI-MUM220 220.00 1	OPEN LINE FROM BUS 374217 [NAVI-MUM 400.00] TO BUS 372365 [NAVI-MUM220 220.00] CKT 2	254	299	315	94.78	SC-1
54.	164486 FATH4 SPL 400.00 163482 FATEHG4-SPL 220.00 1	OPEN LINE FROM BUS 164486 [FATH4 SPL 400.00] TO BUS 163482 [FATEHG4-SPL 220.00] CKT 2	377	472	500	94.34	SC-1
55.	164480 FATEHG-2 400.00 162480 FATEH-2 220.00 1	OPEN LINE FROM BUS 164480 [FATEHG-2 400.00] TO BUS 162480 [FATEH-2 220.00] CKT 2	391	470	500	93.93	SC-1
56.	164495 BIKANER-II 400.00 162495 BIKANER-2 220.00 1	OPEN LINE FROM BUS 164495 [BIKANER-II 400.00] TO BUS 162495 [BIKANER-2 220.00] CKT 10	420	467	500	93.47	SC-1
57.	164480 FATEHG-2 400.00 163480 FATEH-SPL 2 220.00 1	OPEN LINE FROM BUS 164480 [FATEHG-2 400.00] TO BUS 163480 [FATEH-SPL 2 220.00] CKT 2	388	466	500	93.18	SC-1
58.	164431 BASSI 400.00 162283 BASSI 220.00 3	OPEN LINE FROM BUS 164431 [BASSI 400.00] TO BUS 162283 [BASSI 220.00] CKT 1	390	465	500	93.05	SC-1
59.	174058 ORAI 400.00 172124 ORAI 42 220.00 3	OPEN LINE FROM BUS 174058 [ORAI 400.00] TO BUS 172124 [ORAI 42 220.00] CKT 2	150	222	240	92.69	SC-1

S. No.	Monitored Element	Contingency	Base Flow	Maximum Flow	Rate	% loading	Scenario
60.	444422 DURGAPUR-B 400.00 442682 DURGAPUR-A 220.00 1	OPEN LINE FROM BUS 444422 [DURGAPUR-B 400.00] TO BUS 442682 [DURGAPUR-A 220.00] CKT 2	230	291	315	92.51	SC-1
61.	374043 AURANG-CHTPM400.00 372340 PG-AURANGABD220.00 1	OPEN LINE FROM BUS 374043 [AURANG-CHTPM400.00] TO BUS 372340 [PG-AURANGABD220.00] CKT 2	209	291	315	92.39	SC-1
62.	174512 ALIGARH 400.00 172087 ALIGARH 220.00 1	OPEN LINE FROM BUS 174512 [ALIGARH 400.00] TO BUS 172087 [ALIGARH 220.00] CKT 2	332	461	500	92.19	SC-1
63.	544007 HOSUR4 400.00 542076 HOSUR42 230.00 1	OPEN LINE FROM BUS 544007 [HOSUR4 400.00] TO BUS 542076 [HOSUR42 230.00] CKT 4	215	290	315	92.05	SC-1
64.	444421 BIDHAN NGR 400.00 442686 BIDHANNGR-WB220.00 1	OPEN LINE FROM BUS 444421 [BIDHAN NGR 400.00] TO BUS 442686 [BIDHANNGR-WB220.00] CKT 3	229	290	315	91.93	SC-1
65.	374912 PADGHE-SPLT 400.00 372963 PADGHE-SPLT2220.00 5	OPEN LINE FROM BUS 374912 [PADGHE-SPLT 400.00] TO BUS 372963 [PADGHE-SPLT2220.00] CKT 4	322	460	500	91.91	SC-1
66.	314004 BHI4 400.00 312004 BHILAI 220.00 1	OPEN LINE FROM BUS 314004 [BHI4 400.00] TO BUS 312004 [BHILAI 220.00] CKT 2	241	288	315	91.56	SC-1
67.	424050 LAPANGA 400.00 422805 LAPANGA2 220.00 1	OPEN LINE FROM BUS 424050 [LAPANGA 400.00] TO BUS 422805 [LAPANGA2 220.00] CKT 2	203	287	315	91.02	SC-1
68.	134918 JALANDHAR4 400.00 132918 JALANDHAR42 220.00 1	OPEN LINE FROM BUS 134918 [JALANDHAR4 400.00] TO BUS 132918 [JALANDHAR42 220.00] CKT 3	219	285	315	90.62	SC-1
69.	444024 GOKARNA 400.00 442566 GOKARNA 220.00 1	OPEN LINE FROM BUS 444024 [GOKARNA 400.00] TO BUS 442566 [GOKARNA 220.00] CKT 2	230	285	315	90.6	SC-1
70.	134917 LUDHIANA4 400.00 132913 LUDHIANA42 220.00 1	OPEN LINE FROM BUS 134917 [LUDHIANA4 400.00] TO BUS 132913 [LUDHIANA42 220.00] CKT 2	238	285	315	90.58	SC-1
71.	134917 LUDHIANA4 400.00 132913 LUDHIANA42 220.00 2	OPEN LINE FROM BUS 134917 [LUDHIANA4 400.00] TO BUS 132913 [LUDHIANA42 220.00] CKT 3	377	452	500	90.39	SC-1

S. No.	Monitored Element	Contingency	Base Flow	Maximum Flow	Rate	% loading	Scenario
72.	134403 MAKHU4 400.00 132284 MAKHU42 220.00 1	OPEN LINE FROM BUS 134403 [MAKHU4 400.00] TO BUS 132284 [MAKHU42 220.00] CKT 3	215	284	315	90.22	SC-1
73.	444010 SAGARDIGHI_4400.00 442010 SAGARDIGHI_2220.00 1	OPEN LINE FROM BUS 514888 [NIZAMBD2_4 400.00] TO BUS 518888 [NIZAMBD2_7 765.00] CKT 1	209	284	315	90.12	SC-1
74.	444012 KOLAGHAT 400.00 442012 KTPS220 220.00 1	OPEN LINE FROM BUS 444012 [KOLAGHAT 400.00] TO BUS 442012 [KTPS220 220.00] CKT 2	341	506	315	160.78	SC-2
75.	114422 KISHENPUR 400.00 112235 KISHENPUR 220.00 1	OPEN LINE FROM BUS 114422 [KISHENPUR 400.00] TO BUS 112235 [KISHENPUR 220.00] CKT 2	343	428	315	135.96	SC-2
76.	424014 DUBURI 400.00 422564 DUBRI NEW 220.00 1	OPEN LINE FROM BUS 424014 [DUBURI 400.00] TO BUS 422564 [DUBRI NEW 220.00] CKT 2	303	421	315	133.62	SC-2
77.	354015 MUNDRA-APL 400.00 352015 MUNDRA-APL 220.00 1	OPEN LINE FROM BUS 354015 [MUNDRA-APL 400.00] TO BUS 352015 [MUNDRA-APL 220.00] CKT 2	298	410	315	130.13	SC-2
78.	444015 CHANDITALA_N400.00 442015 CHANDITALA_N220.00 1	OPEN LINE FROM BUS 444015 [CHANDITALA_N400.00] TO BUS 442015 [CHANDITALA_N220.00] CKT 2	332	407	315	129.16	SC-2
79.	454001 DURGAPUR TPS400.00 452001 DURGAPUR TPS220.00 1	OPEN LINE FROM BUS 454001 [DURGAPUR TPS400.00] TO BUS 452001 [DURGAPUR TPS220.00] CKT 2	428	613	500	122.64	SC-2
80.	324002 MAGARWADA-DD400.00 322002 MAGARWADA 220.00 1	OPEN LINE FROM BUS 324002 [MAGARWADA-DD400.00] TO BUS 322002 [MAGARWADA 220.00] CKT 2	187	379	315	120.4	SC-2
81.	444018 KHARAGPR-WB 400.00 442018 KHARAGPR-WB 220.00 1	OPEN LINE FROM BUS 444018 [KHARAGPR-WB 400.00] TO BUS 442018 [KHARAGPR-WB 220.00] CKT 2	274	377	315	119.59	SC-2
82.	374072 KALLAM 400.00 372498 KALLAM 220.00 1	OPEN LINE FROM BUS 374072 [KALLAM 400.00] TO BUS 372498 [KALLAM 220.00] CKT 2	447	596	500	119.19	SC-2
83.	174265 REWA 400.00 172112 REWAROAD 220.00 1	OPEN LINE FROM BUS 177262 [MAINPURIUP 765.00] TO BUS 177263 [BARA 765.00] CKT 1	324	365	315	115.84	SC-2

S. No.	Monitored Element	Contingency	Base Flow	Maximum Flow	Rate	% loading	Scenario
84.	164457 SURATG-4 400.00 162257 SURATGARH-42220.00 1	OPEN LINE FROM BUS 164457 [SURATG-4 400.00] TO BUS 162257 [SURATGARH-42220.00] CKT 2	253	350	315	111.07	SC-2
85.	174058 ORAI 400.00 172124 ORAI 42 220.00 3	OPEN LINE FROM BUS 174058 [ORAI 400.00] TO BUS 172124 [ORAI 42 220.00] CKT 2	172	256	240	106.85	SC-2
86.	164416 AJMER 400.00 162329 AJMER42 220.00 1	OPEN LINE FROM BUS 164416 [AJMER 400.00] TO BUS 162329 [AJMER42 220.00] CKT 2	237	329	315	104.43	SC-2
87.	444008 JEERAT 400.00 442685 JEERAT 220.00 1	OPEN LINE FROM BUS 444008 [JEERAT 400.00] TO BUS 442685 [JEERAT 220.00] CKT 2	280	328	315	104.18	SC-2
88.	174512 ALIGARH 400.00 172087 ALIGARH 220.00 1	OPEN LINE FROM BUS 174512 [ALIGARH 400.00] TO BUS 172087 [ALIGARH 220.00] CKT 2	373	518	500	103.5	SC-2
89.	174472 OBRA4 400.00 172062 OBRA2 220.00 3	OPEN LINE FROM BUS 174472 [OBRA4 400.00] TO BUS 172062 [OBRA2 220.00] CKT 1	193	248	240	103.46	SC-2
90.	164409 HINDAU-4 400.00 162207 HINDAU-4 220.00 1	OPEN LINE FROM BUS 164409 [HINDAU-4 400.00] TO BUS 162207 [HINDAU-4 220.00] CKT 2	220	324	315	102.97	SC-2
91.	524022 KOPPAL 400.00 522370 KOPPAL 220.00 1	OPEN LINE FROM BUS 524022 [KOPPAL 400.00] TO BUS 522370 [KOPPAL 220.00] CKT 2	412	515	500	102.96	SC-2
92.	174474 ALLAHABA 400.00 172100 ALLAHABA 220.00 1	OPEN LINE FROM BUS 174474 [ALLAHABA 400.00] TO BUS 172100 [ALLAHABA 220.00] CKT 2	266	320	315	101.61	SC-2
93.	164420 KOTA 400.00 162919 KOTA 220.00 1	OPEN LINE FROM BUS 164420 [KOTA 400.00] TO BUS 162919 [KOTA 220.00] CKT 2	245	315	315	100.09	SC-2
94.	164434 JODH KANKANI400.00 162334 JODHPURN-42 220.00 1	OPEN LINE FROM BUS 164434 [JODH KANKANI400.00] TO BUS 162334 [JODHPURN-42 220.00] CKT 2	243	315	315	100.07	SC-2
95.	164486 FATH4 SPL 400.00 163482 FATEHG4-SPL 220.00 1	OPEN LINE FROM BUS 164486 [FATH4 SPL 400.00] TO BUS 163482 [FATEHG4-SPL 220.00] CKT 2	397	497	500	99.36	SC-2

S. No.	Monitored Element	Contingency	Base Flow	Maximum Flow	Rate	% loading	Scenario
96.	424022 MENDHASAL 400.00 422586 MENDHASAL 220.00 1	OPEN LINE FROM BUS 424022 [MENDHASAL 400.00] TO BUS 422586 [MENDHASAL 220.00] CKT 2	252	312	315	98.91	SC-2
97.	194467 KASHIPU4 400.00 192221 KASHIPU2 220.00 1	OPEN LINE FROM BUS 194467 [KASHIPU4 400.00] TO BUS 192221 [KASHIPU2 220.00] CKT 2	223	306	315	97.17	SC-2
98.	424050 LAPANGA 400.00 422805 LAPANGA2 220.00 1	OPEN LINE FROM BUS 424050 [LAPANGA 400.00] TO BUS 422805 [LAPANGA2 220.00] CKT 2	215	303	315	96.34	SC-2
99.	424016 BOLANGIR 400.00 422611 BOLANGIR 220.00 1	OPEN LINE FROM BUS 424016 [BOLANGIR 400.00] TO BUS 422611 [BOLANGIR 220.00] CKT 2	184	301	315	95.67	SC-2
100.	174058 ORAI 400.00 172124 ORAI 42 220.00 2	OPEN LINE FROM BUS 174058 [ORAI 400.00] TO BUS 172124 [ORAI 42 220.00] CKT 3	226	301	315	95.67	SC-2
101.	174467 SHAHJ-PG 400.00 172107 SHAHJAHAN4 220.00 1	OPEN LINE FROM BUS 174467 [SHAHJ-PG 400.00] TO BUS 172107 [SHAHJAHAN4 220.00] CKT 2	205	301	315	95.66	SC-2
102.	454002 MEJIA-B 400.00 452002 MEJIA-B 220.00 1	OPEN LINE FROM BUS 454002 [MEJIA-B 400.00] TO BUS 452002 [MEJIA-B 220.00] CKT 2	219	300	315	95.16	SC-2
103.	164412 KALISI-4 400.00 162300 KALISIND 220.00 2	OPEN LINE FROM BUS 164412 [KALISI-4 400.00] TO BUS 164463 [ANTA-4 400.00] CKT 1	375	469	500	93.88	SC-2
104.	374041 PARLI-PG 400.00 372241 PARLIPG2 220.00 1	OPEN LINE FROM BUS 374041 [PARLI-PG 400.00] TO BUS 372241 [PARLIPG2 220.00] CKT 2	326	468	500	93.67	SC-2
105.	444422 DURGAPUR-B 400.00 442682 DURGAPUR-A 220.00 1	OPEN LINE FROM BUS 444422 [DURGAPUR-B 400.00] TO BUS 442682 [DURGAPUR-A 220.00] CKT 2	233	295	315	93.6	SC-2
106.	144483 KURUKSHETR 400.00 142287 KURUKSHETRA 220.00 1	OPEN LINE FROM BUS 144483 [KURUKSHETR 400.00] TO BUS 142287 [KURUKSHETRA 220.00] CKT 2	376	467	500	93.39	SC-2
107.	124404 NALLAGAR 400.00 122904 NALLAGAR 220.00 1	OPEN LINE FROM BUS 124404 [NALLAGAR 400.00] TO BUS 122904 [NALLAGAR 220.00] CKT 2	234	292	315	92.84	SC-2

S. No.	Monitored Element	Contingency	Base Flow	Maximum Flow	Rate	% loading	Scenario
108.	164401 AKAL-4 400.00 162280 AKAL-2 220.00 1	OPEN LINE FROM BUS 164401 [AKAL-4 400.00] TO BUS 162280 [AKAL-2 220.00] CKT 2	369	461	500	92.14	SC-2
109.	164428 CHITTOR4 400.00 162228 CHITTOR-42 220.00 1	OPEN LINE FROM BUS 164428 [CHITTOR4 400.00] TO BUS 162228 [CHITTOR-42 220.00] CKT 2	222	290	315	91.93	SC-2
110.	444007 RAJARHAT 400.00 442007 RAJARHAT 220.00 1	OPEN LINE FROM BUS 444007 [RAJARHAT 400.00] TO BUS 442007 [RAJARHAT 220.00] CKT 2	337	459	500	91.8	SC-2
111.	164921 BHIWADI 400.00 162330 BHIWADI 220.00 1	OPEN LINE FROM BUS 164921 [BHIWADI 400.00] TO BUS 162330 [BHIWADI 220.00] CKT 2	247	286	315	90.68	SC-2
112.	314003 KORBA-WEST 400.00 312003 KORBA-WEST 220.00 1	OPEN LINE FROM BUS 318028 [BLPSR WR 765.00] TO BUS 318032 [DHARAMJAIGAR765.00] CKT 1	408	451	500	90.11	SC-2
113.	374012 PADGH4 400.00 372163 PADGHE22 220.00 6	OPEN LINE FROM BUS 374012 [PADGH4 400.00] TO BUS 372163 [PADGHE22 220.00] CKT 1	221	284	315	90.06	SC-2
114.	444012 KOLAGHAT 400.00 442012 KTPS220 220.00 1	OPEN LINE FROM BUS 444012 [KOLAGHAT 400.00] TO BUS 442012 [KTPS220 220.00] CKT 2	258	381	315	121.03	SC-3
115.	354015 MUNDRA-APL 400.00 352015 MUNDRA-APL 220.00 1	OPEN LINE FROM BUS 354015 [MUNDRA-APL 400.00] TO BUS 352015 [MUNDRA-APL 220.00] CKT 2	265	365	315	115.95	SC-3
116.	424014 DUBURI 400.00 422564 DUBRI NEW 220.00 1	OPEN LINE FROM BUS 424014 [DUBURI 400.00] TO BUS 422564 [DUBRI NEW 220.00] CKT 2	259	357	315	113.19	SC-3
117.	374072 KALLAM 400.00 372498 KALLAM 220.00 1	OPEN LINE FROM BUS 374072 [KALLAM 400.00] TO BUS 372498 [KALLAM 220.00] CKT 2	401	534	500	106.76	SC-3
118.	444015 CHANDITALA_N400.00 442015 CHANDITALA_N220.00 1	OPEN LINE FROM BUS 444015 [CHANDITALA_N400.00] TO BUS 442015 [CHANDITALA_N220.00] CKT 2	252	307	315	97.51	SC-3
119.	454001 DURGAPUR TPS400.00 452001 DURGAPUR TPS220.00 1	OPEN LINE FROM BUS 454001 [DURGAPUR TPS400.00] TO BUS 452001 [DURGAPUR TPS220.00] CKT 2	322	462	500	92.39	SC-3

S. No.	Monitored Element	Contingency	Base Flow	Maximum Flow	Rate	% loading	Scenario
120.	444018 KHARAGPR-WB 400.00 442018 KHARAGPR-WB 220.00 1	OPEN LINE FROM BUS 444018 [KHARAGPR-WB 400.00] TO BUS 442018 [KHARAGPR-WB 220.00] CKT 2	209	288	315	91.31	SC-3
121.	114422 KISHENPUR 400.00 112235 KISHENPUR 220.00 1	OPEN LINE FROM BUS 114422 [KISHENPUR 400.00] TO BUS 112235 [KISHENPUR 220.00] CKT 2	560	701	315	222.41	SC-4
122.	164422 RAMG-I 400.00 162422 RAMGARH-I 220.00 1	OPEN LINE FROM BUS 164422 [RAMG-I 400.00] TO BUS 162422 [RAMGARH-I 220.00] CKT 2	436	876	500	175.22	SC-4
123.	164459 BHADLA PG 400.00 162659 BHADLA-SPLT 220.00 1	OPEN LINE FROM BUS 164459 [BHADLA PG 400.00] TO BUS 162659 [BHADLA-SPLT 220.00] CKT 2	360	721	500	144.15	SC-4
124.	164498 BHADLA-2 400.00 162499 BHAD-2 SPLT 220.00 1	OPEN LINE FROM BUS 164498 [BHADLA-2 400.00] TO BUS 162499 [BHAD-2 SPLT 220.00] CKT 2	467	701	500	140.2	SC-4
125.	444012 KOLAGHAT 400.00 442012 KTPS220 220.00 1	OPEN LINE FROM BUS 444012 [KOLAGHAT 400.00] TO BUS 442012 [KTPS220 220.00] CKT 2	291	430	315	136.47	SC-4
126.	504007 CUDP 400.00 502216 CHINAKAMPALL220.00 1	OPEN LINE FROM BUS 504007 [CUDP 400.00] TO BUS 502216 [CHINAKAMPALL220.00] CKT 3	292	402	315	127.59	SC-4
127.	164415 DEEDWANA 400.00 162093 DEEDWANA-42 220.00 1	OPEN LINE FROM BUS 164415 [DEEDWANA 400.00] TO BUS 162093 [DEEDWANA-42 220.00] CKT 2	265	399	315	126.75	SC-4
128.	164428 CHITTOR4 400.00 162228 CHITTOR-42 220.00 1	OPEN LINE FROM BUS 164428 [CHITTOR4 400.00] TO BUS 162228 [CHITTOR-42 220.00] CKT 2	305	396	315	125.65	SC-4
129.	374028 NAGOTHANE 400.00 372150 NAGOTHA2 220.00 1	OPEN LINE FROM BUS 374028 [NAGOTHANE 400.00] TO BUS 372150 [NAGOTHA2 220.00] CKT 2	252	391	315	124	SC-4
130.	174431 KANPUR 400.00 172103 KANPU-PG 220.00 1	OPEN LINE FROM BUS 174431 [KANPUR 400.00] TO BUS 172103 [KANPU-PG 220.00] CKT 2	304	385	315	122.24	SC-4
131.	324002 MAGARWADA-DD400.00 322002 MAGARWADA 220.00 1	OPEN LINE FROM BUS 324002 [MAGARWADA-DD400.00] TO BUS 322002 [MAGARWADA 220.00] CKT 2	189	383	315	121.69	SC-4

S. No.	Monitored Element	Contingency	Base Flow	Maximum Flow	Rate	% loading	Scenario
132.	544132 KAMUTHI4 400.00 542130 KAMUDHI42 230.00 1	OPEN LINE FROM BUS 544132 [KAMUTHI4 400.00] TO BUS 542130 [KAMUDHI42 230.00] CKT 2	193	382	315	121.32	SC-4
133.	424014 DUBURI 400.00 422564 DUBRI NEW 220.00 1	OPEN LINE FROM BUS 424014 [DUBURI 400.00] TO BUS 422564 [DUBRI NEW 220.00] CKT 2	277	380	315	120.77	SC-4
134.	164498 BHADLA-2 400.00 162498 BHADLA-2 220.00 1	OPEN LINE FROM BUS 164498 [BHADLA-2 400.00] TO BUS 162498 [BHADLA-2 220.00] CKT 2	480	600	500	119.96	SC-4
135.	164420 KOTA 400.00 162919 KOTA 220.00 1	OPEN LINE FROM BUS 164420 [KOTA 400.00] TO BUS 162919 [KOTA 220.00] CKT 2	291	375	315	119.13	SC-4
136.	164404 BHADLA 400.00 162285 BHADLA-S 220.00 1	OPEN LINE FROM BUS 164404 [BHADLA 400.00] TO BUS 162285 [BHADLA-S 220.00] CKT 2	448	571	500	114.21	SC-4
137.	164481 FATEHG-3 400.00 162481 FATEHG-3 220.00 1	OPEN LINE FROM BUS 164481 [FATEHG-3 400.00] TO BUS 162481 [FATEHG-3 220.00] CKT 2	456	571	500	114.17	SC-4
138.	164409 HINDAU-4 400.00 162207 HINDAU-4 220.00 1	OPEN LINE FROM BUS 164409 [HINDAU-4 400.00] TO BUS 162207 [HINDAU-4 220.00] CKT 2	243	359	315	114.1	SC-4
139.	454002 MEJIA-B 400.00 452002 MEJIA-B 220.00 1	OPEN LINE FROM BUS 454002 [MEJIA-B 400.00] TO BUS 452002 [MEJIA-B 220.00] CKT 2	263	358	315	113.73	SC-4
140.	444018 KHARAGPR-WB 400.00 442018 KHARAGPR-WB 220.00 1	OPEN LINE FROM BUS 444018 [KHARAGPR-WB 400.00] TO BUS 442018 [KHARAGPR-WB 220.00] CKT 2	257	354	315	112.42	SC-4
141.	504007 CUDP 400.00 502216 CHINAKAMPALL220.00 3	OPEN LINE FROM BUS 504007 [CUDP 400.00] TO BUS 502216 [CHINAKAMPALL220.00] CKT 1	464	561	500	112.12	SC-4
142.	444015 CHANDITALA_N400.00 442015 CHANDITALA_N220.00 1	OPEN LINE FROM BUS 444015 [CHANDITALA_N400.00] TO BUS 442015 [CHANDITALA_N220.00] CKT 2	286	349	315	110.75	SC-4
143.	164406 HERAPU-4 400.00 162211 HIRAPURA 220.00 2	OPEN LINE FROM BUS 164406 [HERAPU-4 400.00] TO BUS 162211 [HIRAPURA 220.00] CKT 1	236	276	250	110.28	SC-4

S. No.	Monitored Element	Contingency	Base Flow	Maximum Flow	Rate	% loading	Scenario
144.	164431 BASSI 400.00 162283 BASSI 220.00 1	OPEN LINE FROM BUS 164431 [BASSI 400.00] TO BUS 162283 [BASSI 220.00] CKT 3	258	346	315	109.94	SC-4
145.	164459 BHADLA PG 400.00 162359 BHADLA-PG 220.00 1	OPEN LINE FROM BUS 164459 [BHADLA PG 400.00] TO BUS 162359 [BHADLA-PG 220.00] CKT 2	458	549	500	109.87	SC-4
146.	134484 PATRAN4 400.00 132241 PATRAN42 220.00 1	OPEN LINE FROM BUS 134484 [PATRAN4 400.00] TO BUS 132241 [PATRAN42 220.00] CKT 2	426	549	500	109.8	SC-4
147.	164484 BHADLA-3 400.00 162484 BHADLA-3 220.00 1	OPEN LINE FROM BUS 164484 [BHADLA-3 400.00] TO BUS 162484 [BHADLA-3 220.00] CKT 2	436	546	500	109.11	SC-4
148.	164484 BHADLA-3 400.00 163484 BHADLA3-SPL 220.00 1	OPEN LINE FROM BUS 164484 [BHADLA-3 400.00] TO BUS 163484 [BHADLA3-SPL 220.00] CKT 2	436	546	500	109.11	SC-4
149.	524050 JAGALUR4 400.00 522158 JAGALUR2 220.00 1	OPEN LINE FROM BUS 524050 [JAGALUR4 400.00] TO BUS 522158 [JAGALUR2 220.00] CKT 2	348	533	500	106.58	SC-4
150.	164406 HERAPU-4 400.00 162211 HIRAPURA 220.00 1	OPEN LINE FROM BUS 164406 [HERAPU-4 400.00] TO BUS 162211 [HIRAPURA 220.00] CKT 2	297	336	315	106.57	SC-4
151.	164405 BHINMAL 400.00 162914 BHINM-PG 220.00 1	OPEN LINE FROM BUS 164405 [BHINMAL 400.00] TO BUS 162914 [BHINM-PG 220.00] CKT 2	247	335	315	106.3	SC-4
152.	134322 ROPAR4 400.00 132322 ROPAR42 220.00 1	OPEN LINE FROM BUS 134322 [ROPAR4 400.00] TO BUS 132322 [ROPAR42 220.00] CKT 2	372	525	500	105.01	SC-4
153.	174058 ORAI 400.00 172124 ORAI 42 220.00 3	OPEN LINE FROM BUS 174058 [ORAI 400.00] TO BUS 172124 [ORAI 42 220.00] CKT 2	169	252	240	104.99	SC-4
154.	374099 WARDHA SPLT 400.00 372071 WARDH_PG 220.00 2	OPEN LINE FROM BUS 374099 [WARDHA SPLT 400.00] TO BUS 372071 [WARDH_PG 220.00] CKT 4	235	331	315	104.94	SC-4
155.	544026 KANAPATT 400.00 542148 KANARP42 230.00 1	OPEN LINE FROM BUS 544026 [KANAPATT 400.00] TO BUS 542148 [KANARP42 230.00] CKT 2	165	330	315	104.67	SC-4

S. No.	Monitored Element	Contingency	Base Flow	Maximum Flow	Rate	% loading	Scenario
156.	164416 AJMER 400.00 162329 AJMER42 220.00 1	OPEN LINE FROM BUS 164416 [AJMER 400.00] TO BUS 162329 [AJMER42 220.00] CKT 2	233	326	315	103.56	SC-4
157.	114013 PANG400SP3 400.00 114011 PANG220SP3 220.00 1	OPEN LINE FROM BUS 114013 [PANG400SP3 400.00] TO BUS 114011 [PANG220SP3 220.00] CKT 2	270	325	315	103.28	SC-4
158.	114012 PANG400SP2 400.00 114010 PANG220SP2 220.00 1	OPEN LINE FROM BUS 114012 [PANG400SP2 400.00] TO BUS 114010 [PANG220SP2 220.00] CKT 2	270	325	315	103.27	SC-4
159.	114008 PANG 400 SP1400.00 114009 LEH_PANG SP 220.00 1	OPEN LINE FROM BUS 114008 [PANG 400 SP1400.00] TO BUS 114009 [LEH_PANG SP 220.00] CKT 2	270	325	315	103.26	SC-4
160.	154497 DWARKA 400.00 152287 DWARKA-II 220.00 3	OPEN LINE FROM BUS 154497 [DWARKA 400.00] TO BUS 152287 [DWARKA-II 220.00] CKT 4	380	516	500	103.11	SC-4
161.	374028 NAGOTHANE 400.00 372150 NAGOTHA2 220.00 2	OPEN LINE FROM BUS 374028 [NAGOTHANE 400.00] TO BUS 372150 [NAGOTHA2 220.00] CKT 1	399	514	500	102.77	SC-4
162.	534952 EDAMAN4 400.00 532003 EDAMON2 220.00 2	OPEN LINE FROM BUS 534952 [EDAMAN4 400.00] TO BUS 532003 [EDAMON2 220.00] CKT 1	238	323	315	102.45	SC-4
163.	444422 DURGAPUR-B 400.00 442682 DURGAPUR-A 220.00 1	OPEN LINE FROM BUS 444422 [DURGAPUR-B 400.00] TO BUS 442682 [DURGAPUR-A 220.00] CKT 2	254	321	315	102	SC-4
164.	164482 FATEHG-4 400.00 162482 FATEHG-4 220.00 1	OPEN LINE FROM BUS 164482 [FATEHG-4 400.00] TO BUS 162482 [FATEHG-4 220.00] CKT 2	407	509	500	101.87	SC-4
165.	124419 DEHAR 400.00 122218 DEHAR 220.00 1	OPEN LINE FROM BUS 124419 [DEHAR 400.00] TO BUS 134407 [RAJPURA4 400.00] CKT 1	242	320	315	101.45	SC-4
166.	354140 CHARANKA 400.00 352141 CHARANKA 220.00 1	OPEN LINE FROM BUS 354140 [CHARANKA 400.00] TO BUS 352141 [CHARANKA 220.00] CKT 2	203	319	315	101.28	SC-4
167.	454001 DURGAPUR TPS400.00 452001 DURGAPUR TPS220.00 1	OPEN LINE FROM BUS 454001 [DURGAPUR TPS400.00] TO BUS 452001 [DURGAPUR TPS220.00] CKT 2	349	505	500	100.97	SC-4

S. No.	Monitored Element	Contingency	Base Flow	Maximum Flow	Rate	% loading	Scenario
168.	164505 BIKANER-3 400.00 162505 BIKANER-3 220.00 1	OPEN LINE FROM BUS 164505 [BIKANER-3 400.00] TO BUS 162505 [BIKANER-3 220.00] CKT 2	402	503	500	100.57	SC-4
169.	364189 DATIYA NEW4 400.00 362189 DATIYA NEW2 220.00 1	OPEN LINE FROM BUS 364189 [DATIYA NEW4 400.00] TO BUS 362189 [DATIYA NEW2 220.00] CKT 2	317	497	500	99.47	SC-4
170.	134925 MALERKOTLA4 400.00 132911 MALERKOTLA42220.00 1	OPEN LINE FROM BUS 134925 [MALERKOTLA4 400.00] TO BUS 132911 [MALERKOTLA42220.00] CKT 3	235	310	315	98.37	SC-4
171.	174512 ALIGARH 400.00 172087 ALIGARH 220.00 1	OPEN LINE FROM BUS 174512 [ALIGARH 400.00] TO BUS 172087 [ALIGARH 220.00] CKT 2	355	491	500	98.23	SC-4
172.	134442 PATIALA4 400.00 132942 PATIALA42 220.00 1	OPEN LINE FROM BUS 134442 [PATIALA4 400.00] TO BUS 132942 [PATIALA42 220.00] CKT 3	252	309	315	97.95	SC-4
173.	134442 PATIALA4 400.00 132942 PATIALA42 220.00 3	OPEN LINE FROM BUS 134442 [PATIALA4 400.00] TO BUS 132942 [PATIALA42 220.00] CKT 4	399	489	500	97.75	SC-4
174.	164431 BASSI 400.00 162283 BASSI 220.00 3	OPEN LINE FROM BUS 164431 [BASSI 400.00] TO BUS 162283 [BASSI 220.00] CKT 1	409	488	500	97.53	SC-4
175.	164480 FATEHG-2 400.00 163480 FATEH-SPL 2 220.00 1	OPEN LINE FROM BUS 164480 [FATEHG-2 400.00] TO BUS 163480 [FATEH-SPL 2 220.00] CKT 2	402	483	500	96.57	SC-4
176.	444421 BIDHAN NGR 400.00 442686 BIDHANNGR-WB220.00 1	OPEN LINE FROM BUS 444421 [BIDHAN NGR 400.00] TO BUS 442686 [BIDHANNGR-WB220.00] CKT 3	240	304	315	96.52	SC-4
177.	164486 FATH4 SPL 400.00 163482 FATEHG4-SPL 220.00 1	OPEN LINE FROM BUS 164486 [FATH4 SPL 400.00] TO BUS 163482 [FATEHG4-SPL 220.00] CKT 2	386	482	500	96.46	SC-4
178.	164495 BIKANER-II 400.00 162495 BIKANER-2 220.00 1	OPEN LINE FROM BUS 164495 [BIKANER-II 400.00] TO BUS 162495 [BIKANER-2 220.00] CKT 10	432	480	500	96.07	SC-4
179.	114476 NEWWANPO 400.00 112276 NEWWANPO 220.00 1	OPEN LINE FROM BUS 114476 [NEWWANPO 400.00] TO BUS 112276 [NEWWANPO 220.00] CKT 2	228	302	315	95.89	SC-4

S. No.	Monitored Element	Contingency	Base Flow	Maximum Flow	Rate	% loading	Scenario
180.	174058 ORAI 400.00 172124 ORAI 42 220.00 2	OPEN LINE FROM BUS 174058 [ORAI 400.00] TO BUS 172124 [ORAI 42 220.00] CKT 3	223	297	315	94.14	SC-4
181.	514104 MAH-TS SEC-A400.00 512082 MAHESH-TS2 220.00 1	OPEN LINE FROM BUS 514104 [MAH-TS SEC-A400.00] TO BUS 512082 [MAHESH-TS2 220.00] CKT 2	372	471	500	94.12	SC-4
182.	504003 NSAGAR 400.00 502271 TALLAPALLI 220.00 1	OPEN LINE FROM BUS 504003 [NSAGAR 400.00] TO BUS 502271 [TALLAPALLI 220.00] CKT 2	248	296	315	94.04	SC-4
183.	174967 BANDA400 400.00 172143 BANDA42 220.00 2	OPEN LINE FROM BUS 174967 [BANDA400 400.00] TO BUS 172143 [BANDA42 220.00] CKT 1	197	296	315	93.98	SC-4
184.	124404 NALLAGAR 400.00 122904 NALLAGAR 220.00 1	OPEN LINE FROM BUS 124404 [NALLAGAR 400.00] TO BUS 122904 [NALLAGAR 220.00] CKT 2	237	296	315	93.95	SC-4
185.	174967 BANDA400 400.00 172143 BANDA42 220.00 1	OPEN LINE FROM BUS 174967 [BANDA400 400.00] TO BUS 172143 [BANDA42 220.00] CKT 2	196	296	315	93.88	SC-4
186.	174402 BARELI4 400.00 172027 BAKNTPR2 220.00 3	OPEN LINE FROM BUS 174402 [BARELI4 400.00] TO BUS 172027 [BAKNTPR2 220.00] CKT 1	238	294	315	93.39	SC-4
187.	354150 DHOLERASP 400.00 352327 DHOLERASP2 220.00 1	OPEN LINE FROM BUS 354150 [DHOLERASP 400.00] TO BUS 352327 [DHOLERASP2 220.00] CKT 2	302	462	500	92.44	SC-4
188.	164480 FATEHG-2 400.00 162480 FATEH-2 220.00 1	OPEN LINE FROM BUS 164480 [FATEHG-2 400.00] TO BUS 162480 [FATEH-2 220.00] CKT 2	384	461	500	92.17	SC-4
189.	444010 SAGARDIGHI_4400.00 442010 SAGARDIGHI_2220.00 1	OPEN LINE FROM BUS 514888 [NIZAMBD2_4 400.00] TO BUS 518888 [NIZAMBD2_7 765.00] CKT 1	213	290	315	91.96	SC-4
190.	374099 WARDHA SPLT 400.00 372071 WARDH_PG 220.00 4	OPEN LINE FROM BUS 374099 [WARDHA SPLT 400.00] TO BUS 372071 [WARDH_PG 220.00] CKT 2	374	458	500	91.63	SC-4
191.	544001 NYVL TS 2 400.00 542012 NLCTS22 230.00 1	OPEN LINE FROM BUS 544001 [NYVL TS 2 400.00] TO BUS 542012 [NLCTS22 230.00] CKT 2	195	229	250	91.44	SC-4

S. No.	Monitored Element	Contingency	Base Flow	Maximum Flow	Rate	% loading	Scenario
192.	444024 GOKARNA 400.00 442566 GOKARNA 220.00 1	OPEN LINE FROM BUS 444024 [GOKARNA 400.00] TO BUS 442566 [GOKARNA 220.00] CKT 2	232	288	315	91.34	SC-4
193.	194467 KASHIPU4 400.00 192221 KASHIPU2 220.00 1	OPEN LINE FROM BUS 194467 [KASHIPU4 400.00] TO BUS 192221 [KASHIPU2 220.00] CKT 2	208	286	315	90.66	SC-4
194.	144480 JINDPG 400.00 142286 JINDPG 220.00 1	OPEN LINE FROM BUS 144480 [JINDPG 400.00] TO BUS 142286 [JINDPG 220.00] CKT 2	350	453	500	90.53	SC-4
195.	424050 LAPANGA 400.00 422805 LAPANGA2 220.00 1	OPEN LINE FROM BUS 424050 [LAPANGA 400.00] TO BUS 422805 [LAPANGA2 220.00] CKT 2	202	285	315	90.47	SC-4
196.	174922 AGRA 400.00 172115 AGRA-PG 220.00 1	OPEN LINE FROM BUS 174922 [AGRA 400.00] TO BUS 172115 [AGRA-PG 220.00] CKT 2	218	284	315	90.22	SC-4
197.	444012 KOLAGHAT 400.00 442012 KTPS220 220.00 1	OPEN LINE FROM BUS 444012 [KOLAGHAT 400.00] TO BUS 442012 [KTPS220 220.00] CKT 2	305	450	315	143	SC-5
198.	114422 KISHENPUR 400.00 112235 KISHENPUR 220.00 1	OPEN LINE FROM BUS 114422 [KISHENPUR 400.00] TO BUS 112235 [KISHENPUR 220.00] CKT 2	337	421	315	133.67	SC-5
199.	174265 REWA 400.00 172112 REWAROAD 220.00 1	OPEN LINE FROM BUS 174474 [ALLAHABA 400.00] TO BUS 172100 [ALLAHABA 220.00] CKT 1	359	403	315	127.93	SC-5
200.	354015 MUNDRA-APL 400.00 352015 MUNDRA-APL 220.00 1	OPEN LINE FROM BUS 354015 [MUNDRA-APL 400.00] TO BUS 352015 [MUNDRA-APL 220.00] CKT 2	276	380	315	120.64	SC-5
201.	164416 AJMER 400.00 162329 AJMER42 220.00 1	OPEN LINE FROM BUS 164416 [AJMER 400.00] TO BUS 162329 [AJMER42 220.00] CKT 2	272	379	315	120.26	SC-5
202.	374072 KALLAM 400.00 372498 KALLAM 220.00 1	OPEN LINE FROM BUS 374072 [KALLAM 400.00] TO BUS 372498 [KALLAM 220.00] CKT 2	447	596	500	119.25	SC-5
203.	424014 DUBURI 400.00 422564 DUBRI NEW 220.00 1	OPEN LINE FROM BUS 424014 [DUBURI 400.00] TO BUS 422564 [DUBRI NEW 220.00] CKT 2	271	375	315	118.94	SC-5

S. No.	Monitored Element	Contingency	Base Flow	Maximum Flow	Rate	% loading	Scenario
204.	324002 MAGARWADA-DD400.00 322002 MAGARWADA 220.00 1	OPEN LINE FROM BUS 324002 [MAGARWADA-DD400.00] TO BUS 322002 [MAGARWADA 220.00] CKT 2	183	371	315	117.84	SC-5
205.	164409 HINDAU-4 400.00 162207 HINDAU-4 220.00 1	OPEN LINE FROM BUS 164409 [HINDAU-4 400.00] TO BUS 162207 [HINDAU-4 220.00] CKT 2	249	370	315	117.5	SC-5
206.	174512 ALIGARH 400.00 172087 ALIGARH 220.00 1	OPEN LINE FROM BUS 174512 [ALIGARH 400.00] TO BUS 172087 [ALIGARH 220.00] CKT 2	419	582	500	116.45	SC-5
207.	454001 DURGAPUR TPS400.00 452001 DURGAPUR TPS220.00 1	OPEN LINE FROM BUS 454001 [DURGAPUR TPS400.00] TO BUS 452001 [DURGAPUR TPS220.00] CKT 2	403	578	500	115.63	SC-5
208.	174474 ALLAHABA 400.00 172100 ALLAHABA 220.00 1	OPEN LINE FROM BUS 174474 [ALLAHABA 400.00] TO BUS 172100 [ALLAHABA 220.00] CKT 2	300	362	315	114.89	SC-5
209.	444015 CHANDITALA_N400.00 442015 CHANDITALA_N220.00 1	OPEN LINE FROM BUS 444015 [CHANDITALA_N400.00] TO BUS 442015 [CHANDITALA_N220.00] CKT 2	296	362	315	114.82	SC-5
210.	164434 JODH KANKANI400.00 162334 JODHPURN-42 220.00 1	OPEN LINE FROM BUS 164434 [JODH KANKANI400.00] TO BUS 162334 [JODHPURN-42 220.00] CKT 2	277	359	315	114.1	SC-5
211.	174058 ORAI 400.00 172124 ORAI 42 220.00 3	OPEN LINE FROM BUS 174058 [ORAI 400.00] TO BUS 172124 [ORAI 42 220.00] CKT 2	174	259	240	107.94	SC-5
212.	174467 SHAHJ-PG 400.00 172107 SHAHJAHAN4 220.00 1	OPEN LINE FROM BUS 174467 [SHAHJ-PG 400.00] TO BUS 172107 [SHAHJAHAN4 220.00] CKT 2	230	340	315	107.9	SC-5
213.	444018 KHARAGPR-WB 400.00 442018 KHARAGPR-WB 220.00 1	OPEN LINE FROM BUS 444018 [KHARAGPR-WB 400.00] TO BUS 442018 [KHARAGPR-WB 220.00] CKT 2	245	337	315	106.85	SC-5
214.	174472 OBRA4 400.00 172062 OBRA2 220.00 3	OPEN LINE FROM BUS 174472 [OBRA4 400.00] TO BUS 172062 [OBRA2 220.00] CKT 1	199	256	240	106.59	SC-5
215.	164400 MERTA 400.00 162200 MERTA-42 220.00 1	OPEN LINE FROM BUS 164400 [MERTA 400.00] TO BUS 162200 [MERTA-42 220.00] CKT 2	234	327	315	103.72	SC-5

S. No.	Monitored Element	Contingency	Base Flow	Maximum Flow	Rate	% loading	Scenario
216.	164428 CHITTOR4 400.00 162228 CHITTOR-42 220.00 1	OPEN LINE FROM BUS 164428 [CHITTOR4 400.00] TO BUS 162228 [CHITTOR-42 220.00] CKT 2	249	325	315	103.08	SC-5
217.	524022 KOPPAL 400.00 522370 KOPPAL 220.00 1	OPEN LINE FROM BUS 524022 [KOPPAL 400.00] TO BUS 522370 [KOPPAL 220.00] CKT 2	411	515	500	102.99	SC-5
218.	174927 GORAKHPU 400.00 172101 GORAK-PG 220.00 1	OPEN LINE FROM BUS 174927 [GORAKHPU 400.00] TO BUS 172101 [GORAK-PG 220.00] CKT 2	261	321	315	102.05	SC-5
219.	164921 BHIWADI 400.00 162330 BHIWADI 220.00 1	OPEN LINE FROM BUS 164921 [BHIWADI 400.00] TO BUS 162330 [BHIWADI 220.00] CKT 2	274	318	315	100.87	SC-5
220.	174922 AGRA 400.00 172115 AGRA-PG 220.00 1	OPEN LINE FROM BUS 174922 [AGRA 400.00] TO BUS 172115 [AGRA-PG 220.00] CKT 2	243	317	315	100.49	SC-5
221.	164420 KOTA 400.00 162919 KOTA 220.00 1	OPEN LINE FROM BUS 164420 [KOTA 400.00] TO BUS 162919 [KOTA 220.00] CKT 2	245	316	315	100.47	SC-5
222.	174438 LUCK4-PG 400.00 172098 LUCKNOW 220.00 1	OPEN LINE FROM BUS 174438 [LUCK4-PG 400.00] TO BUS 172098 [LUCKNOW 220.00] CKT 2	351	493	500	98.64	SC-5
223.	144483 KURUKSHETR 400.00 142287 KURUKSHETRA 220.00 1	OPEN LINE FROM BUS 144483 [KURUKSHETR 400.00] TO BUS 142287 [KURUKSHETRA 220.00] CKT 2	396	492	500	98.43	SC-5
224.	164406 HERAPU-4 400.00 162211 HIRAPURA 220.00 2	OPEN LINE FROM BUS 164406 [HERAPU-4 400.00] TO BUS 162211 [HIRAPURA 220.00] CKT 1	210	245	250	98.11	SC-5
225.	174465 FATEH-PG 400.00 172097 FATEH-PG 220.00 3	OPEN LINE FROM BUS 174465 [FATEH-PG 400.00] TO BUS 172097 [FATEH-PG 220.00] CKT 1	255	305	315	96.74	SC-5
226.	174058 ORAI 400.00 172124 ORAI 42 220.00 2	OPEN LINE FROM BUS 174058 [ORAI 400.00] TO BUS 172124 [ORAI 42 220.00] CKT 3	228	304	315	96.64	SC-5
227.	144410 NUHIYANWALI 400.00 142263 NUHIYANWALI 220.00 1	OPEN LINE FROM BUS 144410 [NUHIYANWALI 400.00] TO BUS 142263 [NUHIYANWALI 220.00] CKT 2	203	304	315	96.46	SC-5

S. No.	Monitored Element	Contingency	Base Flow	Maximum Flow	Rate	% loading	Scenario
228.	154497 DWARKA 400.00 152287 DWARKA-II 220.00 3	OPEN LINE FROM BUS 154497 [DWARKA 400.00] TO BUS 152287 [DWARKA-II 220.00] CKT 4	350	482	500	96.32	SC-5
229.	174499 MATHURA-UP 400.00 172128 MATHURA 220.00 1	OPEN LINE FROM BUS 174499 [MATHURA-UP 400.00] TO BUS 172128 [MATHURA 220.00] CKT 2	198	301	315	95.43	SC-5
230.	164415 DEEDWANA 400.00 162093 DEEDWANA-42 220.00 1	OPEN LINE FROM BUS 164415 [DEEDWANA 400.00] TO BUS 162093 [DEEDWANA-42 220.00] CKT 2	199	300	315	95.18	SC-5
231.	144480 JINDPG 400.00 142286 JINDPG 220.00 1	OPEN LINE FROM BUS 144480 [JINDPG 400.00] TO BUS 142286 [JINDPG 220.00] CKT 2	366	476	500	95.15	SC-5
232.	164406 HERAPU-4 400.00 162211 HIRAPURA 220.00 1	OPEN LINE FROM BUS 164406 [HERAPU-4 400.00] TO BUS 162211 [HIRAPURA 220.00] CKT 2	264	299	315	94.77	SC-5
233.	444422 DURGAPUR-B 400.00 442682 DURGAPUR-A 220.00 1	OPEN LINE FROM BUS 444422 [DURGAPUR-B 400.00] TO BUS 442682 [DURGAPUR-A 220.00] CKT 2	235	297	315	94.41	SC-5
234.	164486 FATH4 SPL 400.00 163482 FATEHG4-SPL 220.00 1	OPEN LINE FROM BUS 164486 [FATH4 SPL 400.00] TO BUS 163482 [FATEHG4-SPL 220.00] CKT 2	377	471	500	94.27	SC-5
235.	174466 PANKI4 400.00 172056 PANKI2 220.00 1	OPEN LINE FROM BUS 174466 [PANKI4 400.00] TO BUS 172056 [PANKI2 220.00] CKT 2	233	296	315	94.12	SC-5
236.	124404 NALLAGAR 400.00 122904 NALLAGAR 220.00 1	OPEN LINE FROM BUS 124404 [NALLAGAR 400.00] TO BUS 122904 [NALLAGAR 220.00] CKT 2	235	294	315	93.21	SC-5
237.	174993 JEHTA_HARDOI400.00 172987 JEHTA_HARDOI220.00 1	OPEN LINE FROM BUS 174993 [JEHTA_HARDOI400.00] TO BUS 172987 [JEHTA_HARDOI220.00] CKT 2	322	466	500	93.19	SC-5
238.	174490 BASTI 400.00 172490 BASTI 220.00 1	OPEN LINE FROM BUS 174490 [BASTI 400.00] TO BUS 172490 [BASTI 220.00] CKT 2	331	465	500	92.95	SC-5
239.	174467 SHAHJ-PG 400.00 172107 SHAHJAHAN4 220.00 2	OPEN LINE FROM BUS 174467 [SHAHJ-PG 400.00] TO BUS 172107 [SHAHJAHAN4 220.00] CKT 1	359	453	491	92.22	SC-5

S. No.	Monitored Element	Contingency	Base Flow	Maximum Flow	Rate	% loading	Scenario
240.	174462 MAINPURI 400.00 172099 MAINPURI-PG 220.00 1	OPEN LINE FROM BUS 174462 [MAINPURI 400.00] TO BUS 172099 [MAINPURI-PG 220.00] CKT 3	213	290	315	91.95	SC-5
241.	164410 BHILWA-4 400.00 162288 BHILWA-4 220.00 1	OPEN LINE FROM BUS 164410 [BHILWA-4 400.00] TO BUS 162288 [BHILWA-4 220.00] CKT 2	218	288	315	91.58	SC-5
242.	174002 BAGPAT 400.00 172114 BAGPAT-PG 220.00 1	OPEN LINE FROM BUS 174002 [BAGPAT 400.00] TO BUS 172114 [BAGPAT-PG 220.00] CKT 2	333	457	500	91.48	SC-5
243.	174471 ROSA-TP2 400.00 172022 ROSA-TP1 220.00 1	OPEN LINE FROM BUS 174467 [SHAHJ-PG 400.00] TO BUS 172107 [SHAHJAHAN4 220.00] CKT 2	150	182	200	91.08	SC-5
244.	454002 MEJIA-B 400.00 452002 MEJIA-B 220.00 1	OPEN LINE FROM BUS 454002 [MEJIA-B 400.00] TO BUS 452002 [MEJIA-B 220.00] CKT 2	210	286	315	90.92	SC-5
245.	444008 JEERAT 400.00 442685 JEERAT 220.00 1	OPEN LINE FROM BUS 444008 [JEERAT 400.00] TO BUS 442685 [JEERAT 220.00] CKT 2	244	286	315	90.9	SC-5
246.	164431 BASSI 400.00 162283 BASSI 220.00 1	OPEN LINE FROM BUS 164431 [BASSI 400.00] TO BUS 162283 [BASSI 220.00] CKT 3	213	286	315	90.81	SC-5
247.	174431 KANPUR 400.00 172103 KANPU-PG 220.00 1	OPEN LINE FROM BUS 174431 [KANPUR 400.00] TO BUS 172103 [KANPU-PG 220.00] CKT 2	225	286	315	90.72	SC-5
248.	164401 AKAL-4 400.00 162280 AKAL-2 220.00 4	OPEN LINE FROM BUS 164401 [AKAL-4 400.00] TO BUS 162280 [AKAL-2 220.00] CKT 2	228	285	315	90.57	SC-5
249.	534952 EDAMAN4 400.00 532003 EDAMON2 220.00 2	OPEN LINE FROM BUS 534952 [EDAMAN4 400.00] TO BUS 532003 [EDAMON2 220.00] CKT 1	209	284	315	90.25	SC-5
250.	414071 KISHANGANJ 400.00 412101 KISHENGAN-PG220.00 1	OPEN LINE FROM BUS 414071 [KISHANGANJ 400.00] TO BUS 412101 [KISHENGAN-PG220.00] CKT 2	322	450	500	90.1	SC-5
251.	164412 KALISI-4 400.00 162300 KALISIND 220.00 2	OPEN LINE FROM BUS 164412 [KALISI-4 400.00] TO BUS 164463 [ANTA-4 400.00] CKT 1	355	450	500	90.05	SC-5

S. No.	Monitored Element	Contingency	Base Flow	Maximum Flow	Rate	% loading	Scenario
252.	354015 MUNDRA-APL 400.00 352015 MUNDRA-APL 220.00 1	OPEN LINE FROM BUS 354015 [MUNDRA-APL 400.00] TO BUS 352015 [MUNDRA-APL 220.00] CKT 2	263	362	315	114.82	SC-6
253.	454002 MEJIA-B 400.00 452002 MEJIA-B 220.00 1	OPEN LINE FROM BUS 454002 [MEJIA-B 400.00] TO BUS 452002 [MEJIA-B 220.00] CKT 2	259	354	315	112.35	SC-6
254.	454001 DURGAPUR TPS400.00 452001 DURGAPUR TPS220.00 1	OPEN LINE FROM BUS 454001 [DURGAPUR TPS400.00] TO BUS 452001 [DURGAPUR TPS220.00] CKT 2	380	547	500	109.47	SC-6
255.	324002 MAGARWADA-DD400.00 322002 MAGARWADA 220.00 1	OPEN LINE FROM BUS 324002 [MAGARWADA-DD400.00] TO BUS 322002 [MAGARWADA 220.00] CKT 2	164	333	315	105.71	SC-6
256.	424014 DUBURI 400.00 422564 DUBRI NEW 220.00 1	OPEN LINE FROM BUS 424014 [DUBURI 400.00] TO BUS 422564 [DUBRI NEW 220.00] CKT 2	236	327	315	103.79	SC-6
257.	374072 KALLAM 400.00 372498 KALLAM 220.00 1	OPEN LINE FROM BUS 374072 [KALLAM 400.00] TO BUS 372498 [KALLAM 220.00] CKT 2	389	518	500	103.56	SC-6
258.	444422 DURGAPUR-B 400.00 442682 DURGAPUR-A 220.00 1	OPEN LINE FROM BUS 444422 [DURGAPUR-B 400.00] TO BUS 442682 [DURGAPUR-A 220.00] CKT 2	249	315	315	100.14	SC-6
259.	444012 KOLAGHAT 400.00 442012 KTPS220 220.00 1	OPEN LINE FROM BUS 444012 [KOLAGHAT 400.00] TO BUS 442012 [KTPS220 220.00] CKT 2	207	308	315	97.86	SC-6
260.	484002 BOKARO-A 400.00 482001 BOKARO TPS 220.00 1	OPEN LINE FROM BUS 484002 [BOKARO-A 400.00] TO BUS 482001 [BOKARO TPS 220.00] CKT 2	304	469	500	93.72	SC-6
261.	524022 KOPPAL 400.00 522370 KOPPAL 220.00 1	OPEN LINE FROM BUS 524022 [KOPPAL 400.00] TO BUS 522370 [KOPPAL 220.00] CKT 2	363	453	500	90.67	SC-6
262.	164422 RAMG-I 400.00 162422 RAMGARH-I 220.00 1	OPEN LINE FROM BUS 164422 [RAMG-I 400.00] TO BUS 162422 [RAMGARH-I 220.00] CKT 2	440	884	500	176.85	SC-7
263.	114422 KISHENPUR 400.00 112235 KISHENPUR 220.00 1	OPEN LINE FROM BUS 114422 [KISHENPUR 400.00] TO BUS 112235 [KISHENPUR 220.00] CKT 2	422	527	315	167.42	SC-7

S. No.	Monitored Element	Contingency	Base Flow	Maximum Flow	Rate	% loading	Scenario
264.	364189 DATIYA NEW4 400.00 362189 DATIYA NEW2 220.00 1	OPEN LINE FROM BUS 364189 [DATIYA NEW4 400.00] TO BUS 362189 [DATIYA NEW2 220.00] CKT 2	473	737	500	147.42	SC-7
265.	164459 BHADLA PG 400.00 162659 BHADLA-SPLT 220.00 1	OPEN LINE FROM BUS 164459 [BHADLA PG 400.00] TO BUS 162659 [BHADLA-SPLT 220.00] CKT 2	358	718	500	143.56	SC-7
266.	164420 KOTA 400.00 162919 KOTA 220.00 1	OPEN LINE FROM BUS 164420 [KOTA 400.00] TO BUS 162919 [KOTA 220.00] CKT 2	344	443	315	140.71	SC-7
267.	164498 BHADLA-2 400.00 162499 BHAD-2 SPLT 220.00 1	OPEN LINE FROM BUS 164498 [BHADLA-2 400.00] TO BUS 162499 [BHAD-2 SPLT 220.00] CKT 2	463	696	500	139.19	SC-7
268.	544132 KAMUTHI4 400.00 542130 KAMUDHI42 230.00 1	OPEN LINE FROM BUS 544132 [KAMUTHI4 400.00] TO BUS 542130 [KAMUDHI42 230.00] CKT 2	206	419	315	132.9	SC-7
269.	164428 CHITTOR4 400.00 162228 CHITTOR-42 220.00 1	OPEN LINE FROM BUS 164428 [CHITTOR4 400.00] TO BUS 162228 [CHITTOR-42 220.00] CKT 2	307	400	315	127.1	SC-7
270.	504007 CUDP 400.00 502216 CHINAKAMPALL220.00 1	OPEN LINE FROM BUS 504007 [CUDP 400.00] TO BUS 502216 [CHINAKAMPALL220.00] CKT 3	289	398	315	126.38	SC-7
271.	424014 DUBURI 400.00 422564 DUBRI NEW 220.00 1	OPEN LINE FROM BUS 424014 [DUBURI 400.00] TO BUS 422564 [DUBRI NEW 220.00] CKT 2	282	391	315	124.18	SC-7
272.	324002 MAGARWADA-DD400.00 322002 MAGARWADA 220.00 1	OPEN LINE FROM BUS 324002 [MAGARWADA-DD400.00] TO BUS 322002 [MAGARWADA 220.00] CKT 2	191	389	315	123.53	SC-7
273.	164409 HINDAU-4 400.00 162207 HINDAU-4 220.00 1	OPEN LINE FROM BUS 164409 [HINDAU-4 400.00] TO BUS 162207 [HINDAU-4 220.00] CKT 2	254	375	315	119.14	SC-7
274.	164498 BHADLA-2 400.00 162498 BHADLA-2 220.00 1	OPEN LINE FROM BUS 164498 [BHADLA-2 400.00] TO BUS 162498 [BHADLA-2 220.00] CKT 2	475	595	500	118.97	SC-7
275.	164481 FATEHG-3 400.00 162481 FATEHG-3 220.00 1	OPEN LINE FROM BUS 164481 [FATEHG-3 400.00] TO BUS 162481 [FATEHG-3 220.00] CKT 2	473	592	500	118.47	SC-7

S. No.	Monitored Element	Contingency	Base Flow	Maximum Flow	Rate	% loading	Scenario
276.	424050 LAPANGA 400.00 422805 LAPANGA2 220.00 1	OPEN LINE FROM BUS 424050 [LAPANGA 400.00] TO BUS 422805 [LAPANGA2 220.00] CKT 2	262	371	315	117.74	SC-7
277.	374099 WARDHA SPLT 400.00 372071 WARDH_PG 220.00 2	OPEN LINE FROM BUS 374099 [WARDHA SPLT 400.00] TO BUS 372071 [WARDH_PG 220.00] CKT 4	262	369	315	117.23	SC-7
278.	164416 AJMER 400.00 162329 AJMER42 220.00 1	OPEN LINE FROM BUS 164416 [AJMER 400.00] TO BUS 162329 [AJMER42 220.00] CKT 2	254	354	315	112.47	SC-7
279.	164415 DEEDWANA 400.00 162093 DEEDWANA-42 220.00 1	OPEN LINE FROM BUS 164415 [DEEDWANA 400.00] TO BUS 162093 [DEEDWANA-42 220.00] CKT 2	233	350	315	111.1	SC-7
280.	504007 CUDP 400.00 502216 CHINAKAMPALL220.00 3	OPEN LINE FROM BUS 504007 [CUDP 400.00] TO BUS 502216 [CHINAKAMPALL220.00] CKT 1	459	555	500	110.97	SC-7
281.	164459 BHADLA PG 400.00 162359 BHADLA-PG 220.00 1	OPEN LINE FROM BUS 164459 [BHADLA PG 400.00] TO BUS 162359 [BHADLA-PG 220.00] CKT 2	460	553	500	110.51	SC-7
282.	164484 BHADLA-3 400.00 162484 BHADLA-3 220.00 1	OPEN LINE FROM BUS 164484 [BHADLA-3 400.00] TO BUS 162484 [BHADLA-3 220.00] CKT 2	440	551	500	110.11	SC-7
283.	164484 BHADLA-3 400.00 163484 BHADLA3-SPL 220.00 1	OPEN LINE FROM BUS 164484 [BHADLA-3 400.00] TO BUS 163484 [BHADLA3-SPL 220.00] CKT 2	440	551	500	110.11	SC-7
284.	454002 MEJIA-B 400.00 452002 MEJIA-B 220.00 1	OPEN LINE FROM BUS 454002 [MEJIA-B 400.00] TO BUS 452002 [MEJIA-B 220.00] CKT 2	253	344	315	109.3	SC-7
285.	164405 BHINMAL 400.00 162914 BHINM-PG 220.00 1	OPEN LINE FROM BUS 164405 [BHINMAL 400.00] TO BUS 162914 [BHINM-PG 220.00] CKT 2	253	344	315	109.14	SC-7
286.	444012 KOLAGHAT 400.00 442012 KTPS220 220.00 1	OPEN LINE FROM BUS 444012 [KOLAGHAT 400.00] TO BUS 442012 [KTPS220 220.00] CKT 2	231	343	315	108.93	SC-7
287.	164406 HERAPU-4 400.00 162211 HIRAPURA 220.00 2	OPEN LINE FROM BUS 164406 [HERAPU-4 400.00] TO BUS 162211 [HIRAPURA 220.00] CKT 1	232	271	250	108.47	SC-7

S. No.	Monitored Element	Contingency	Base Flow	Maximum Flow	Rate	% loading	Scenario
288.	534952 EDAMAN4 400.00 532003 EDAMON2 220.00 2	OPEN LINE FROM BUS 534952 [EDAMAN4 400.00] TO BUS 532003 [EDAMON2 220.00] CKT 1	249	337	315	107.04	SC-7
289.	164431 BASSI 400.00 162283 BASSI 220.00 1	OPEN LINE FROM BUS 164431 [BASSI 400.00] TO BUS 162283 [BASSI 220.00] CKT 3	250	336	315	106.52	SC-7
290.	374043 AURANG-CHTPM400.00 372340 PG-AURANGABD220.00 1	OPEN LINE FROM BUS 374043 [AURANG-CHTPM400.00] TO BUS 372340 [PG-AURANGABD220.00] CKT 2	240	334	315	106.08	SC-7
291.	164406 HERAPU-4 400.00 162211 HIRAPURA 220.00 1	OPEN LINE FROM BUS 164406 [HERAPU-4 400.00] TO BUS 162211 [HIRAPURA 220.00] CKT 2	292	330	315	104.82	SC-7
292.	484002 BOKARO-A 400.00 482001 BOKARO TPS 220.00 1	OPEN LINE FROM BUS 484002 [BOKARO-A 400.00] TO BUS 482001 [BOKARO TPS 220.00] CKT 2	340	522	500	104.46	SC-7
293.	114013 PANG400SP3 400.00 114011 PANG220SP3 220.00 1	OPEN LINE FROM BUS 114013 [PANG400SP3 400.00] TO BUS 114011 [PANG220SP3 220.00] CKT 2	273	328	315	104.25	SC-7
294.	114012 PANG400SP2 400.00 114010 PANG220SP2 220.00 1	OPEN LINE FROM BUS 114012 [PANG400SP2 400.00] TO BUS 114010 [PANG220SP2 220.00] CKT 2	273	328	315	104.24	SC-7
295.	114008 PANG 400 SP1400.00 114009 LEH_PANG SP 220.00 1	OPEN LINE FROM BUS 114008 [PANG 400 SP1400.00] TO BUS 114009 [LEH_PANG SP 220.00] CKT 2	273	328	315	104.23	SC-7
296.	354140 CHARANKA 400.00 352141 CHARANKA 220.00 1	OPEN LINE FROM BUS 354140 [CHARANKA 400.00] TO BUS 352141 [CHARANKA 220.00] CKT 2	207	327	315	103.9	SC-7
297.	374217 NAVI-MUM 400.00 372365 NAVI-MUM220 220.00 1	OPEN LINE FROM BUS 374217 [NAVI-MUM 400.00] TO BUS 372365 [NAVI-MUM220 220.00] CKT 2	275	324	315	102.9	SC-7
298.	164482 FATEHG-4 400.00 162482 FATEHG-4 220.00 1	OPEN LINE FROM BUS 164482 [FATEHG-4 400.00] TO BUS 162482 [FATEHG-4 220.00] CKT 2	411	514	500	102.81	SC-7
299.	524169 PEENYA4 400.00 522363 PENYA22 220.00 1	OPEN LINE FROM BUS 524169 [PEENYA4 400.00] TO BUS 522363 [PENYA22 220.00] CKT 2	355	512	500	102.45	SC-7

S. No.	Monitored Element	Contingency	Base Flow	Maximum Flow	Rate	% loading	Scenario
300.	374099 WARDHA SPLT 400.00 372071 WARDH_PG 220.00 4	OPEN LINE FROM BUS 374099 [WARDHA SPLT 400.00] TO BUS 372071 [WARDH_PG 220.00] CKT 2	418	511	500	102.21	SC-7
301.	374028 NAGOTHANE 400.00 372150 NAGOTHA2 220.00 1	OPEN LINE FROM BUS 374028 [NAGOTHANE 400.00] TO BUS 372150 [NAGOTHA2 220.00] CKT 2	206	320	315	101.66	SC-7
302.	164505 BIKANER-3 400.00 162505 BIKANER-3 220.00 1	OPEN LINE FROM BUS 164505 [BIKANER-3 400.00] TO BUS 162505 [BIKANER-3 220.00] CKT 2	401	501	500	100.2	SC-7
303.	354150 DHOLERASP 400.00 352327 DHOLERASP2 220.00 1	OPEN LINE FROM BUS 354150 [DHOLERASP 400.00] TO BUS 352327 [DHOLERASP2 220.00] CKT 2	323	497	500	99.39	SC-7
304.	374002 KHARGAR 400.00 372125 KHARGR22 220.00 1	OPEN LINE FROM BUS 374002 [KHARGAR 400.00] TO BUS 372125 [KHARGR22 220.00] CKT 3	262	308	315	97.77	SC-7
305.	374912 PADGHE-SPLT 400.00 372963 PADGHE-SPLT2220.00 5	OPEN LINE FROM BUS 374912 [PADGHE-SPLT 400.00] TO BUS 372963 [PADGHE-SPLT2220.00] CKT 4	342	488	500	97.63	SC-7
306.	164480 FATEHG-2 400.00 162480 FATEH-2 220.00 1	OPEN LINE FROM BUS 164480 [FATEHG-2 400.00] TO BUS 162480 [FATEH-2 220.00] CKT 2	406	487	500	97.44	SC-7
307.	164495 BIKANER-II 400.00 162495 BIKANER-2 220.00 1	OPEN LINE FROM BUS 164495 [BIKANER-II 400.00] TO BUS 162495 [BIKANER-2 220.00] CKT 10	436	485	500	96.96	SC-7
308.	164480 FATEHG-2 400.00 163480 FATEH-SPL 2 220.00 1	OPEN LINE FROM BUS 164480 [FATEHG-2 400.00] TO BUS 163480 [FATEH-SPL 2 220.00] CKT 2	402	483	500	96.65	SC-7
309.	114476 NEWWANPO 400.00 112276 NEWWANPO 220.00 1	OPEN LINE FROM BUS 114476 [NEWWANPO 400.00] TO BUS 112276 [NEWWANPO 220.00] CKT 2	226	299	315	95.02	SC-7
310.	164431 BASSI 400.00 162283 BASSI 220.00 3	OPEN LINE FROM BUS 164431 [BASSI 400.00] TO BUS 162283 [BASSI 220.00] CKT 1	397	473	500	94.5	SC-7
311.	374996 KALWA-SPLT 400.00 372996 KALWA-SPLT 220.00 1	OPEN LINE FROM BUS 374996 [KALWA-SPLT 400.00] TO BUS 372996 [KALWA-SPLT 220.00] CKT 2	372	471	500	94.24	SC-7

S. No.	Monitored Element	Contingency	Base Flow	Maximum Flow	Rate	% loading	Scenario
312.	374040 SOLAPUR-PG 400.00 372333 SOLPR-PG22 220.00 1	OPEN LINE FROM BUS 374040 [SOLAPUR-PG 400.00] TO BUS 372333 [SOLPR-PG22 220.00] CKT 3	197	294	315	93.33	SC-7
313.	374002 KHARGAR 400.00 372125 KHARGR22 220.00 3	OPEN LINE FROM BUS 374002 [KHARGAR 400.00] TO BUS 372125 [KHARGR22 220.00] CKT 1	418	461	500	92.2	SC-7
314.	454001 DURGAPUR TPS400.00 452001 DURGAPUR TPS220.00 1	OPEN LINE FROM BUS 454001 [DURGAPUR TPS400.00] TO BUS 452001 [DURGAPUR TPS220.00] CKT 2	320	458	500	91.59	SC-7
315.	164404 BHADLA 400.00 162285 BHADLA-S 220.00 1	OPEN LINE FROM BUS 164404 [BHADLA 400.00] TO BUS 162285 [BHADLA-S 220.00] CKT 2	361	456	500	91.14	SC-7
316.	364039 MANDSAUR-4 400.00 362113 MANDSOUR-42 220.00 1	OPEN LINE FROM BUS 364039 [MANDSAUR-4 400.00] TO BUS 362113 [MANDSOUR-42 220.00] CKT 2	202	286	315	90.85	SC-7
317.	444422 DURGAPUR-B 400.00 442682 DURGAPUR-A 220.00 1	OPEN LINE FROM BUS 444422 [DURGAPUR-B 400.00] TO BUS 442682 [DURGAPUR-A 220.00] CKT 2	226	285	315	90.63	SC-7
318.	164473 JAIPUR_PG 400.00 162973 JAIPUR_PG 220.00 1	OPEN LINE FROM BUS 164473 [JAIPUR_PG 400.00] TO BUS 162973 [JAIPUR_PG 220.00] CKT 2	316	453	500	90.57	SC-7
319.	544046 NEY(REP)4 400.00 542184 NNTPS2 230.00 1	OPEN LINE FROM BUS 544046 [NEY(REP)4 400.00] TO BUS 542184 [NNTPS2 230.00] CKT 2	329	453	500	90.52	SC-7
320.	474028 DALTONGANJ 400.00 472228 DALTONGANJ_2220.00 1	OPEN LINE FROM BUS 474028 [DALTONGANJ 400.00] TO BUS 472228 [DALTONGANJ_2220.00] CKT 2	176	284	315	90.21	SC-7
321.	324002 MAGARWADA-DD400.00 322002 MAGARWADA 220.00 1	OPEN LINE FROM BUS 324002 [MAGARWADA-DD400.00] TO BUS 322002 [MAGARWADA 220.00] CKT 2	202	411	315	130.57	SC-8
322.	424014 DUBURI 400.00 422564 DUBRI NEW 220.00 1	OPEN LINE FROM BUS 424014 [DUBURI 400.00] TO BUS 422564 [DUBRI NEW 220.00] CKT 2	286	400	315	126.92	SC-8
323.	164412 KALISI-4 400.00 162300 KALISIND 220.00 2	OPEN LINE FROM BUS 164412 [KALISI-4 400.00] TO BUS 164485 [SANGOD 400.00] CKT 1	537	614	500	122.77	SC-8

S. No.	Monitored Element	Contingency	Base Flow	Maximum Flow	Rate	% loading	Scenario
324.	164434 JODH KANKANI400.00 162334 JODHPURN-42 220.00 1	OPEN LINE FROM BUS 164434 [JODH KANKANI400.00] TO BUS 162334 [JODHPURN-42 220.00] CKT 2	297	385	315	122.21	SC-8
325.	534952 EDAMAN4 400.00 532003 EDAMON2 220.00 2	OPEN LINE FROM BUS 534952 [EDAMAN4 400.00] TO BUS 532003 [EDAMON2 220.00] CKT 1	261	354	315	112.34	SC-8
326.	424050 LAPANGA 400.00 422805 LAPANGA2 220.00 1	OPEN LINE FROM BUS 424050 [LAPANGA 400.00] TO BUS 422805 [LAPANGA2 220.00] CKT 2	249	353	315	111.92	SC-8
327.	424022 MENDHASAL 400.00 422586 MENDHASAL 220.00 1	OPEN LINE FROM BUS 424022 [MENDHASAL 400.00] TO BUS 422586 [MENDHASAL 220.00] CKT 2	272	336	315	106.73	SC-8
328.	544046 NEY(REP)4 400.00 542184 NNTPS2 230.00 1	OPEN LINE FROM BUS 544046 [NEY(REP)4 400.00] TO BUS 542184 [NNTPS2 230.00] CKT 2	375	517	500	103.41	SC-8
329.	164416 AJMER 400.00 162329 AJMER42 220.00 1	OPEN LINE FROM BUS 164416 [AJMER 400.00] TO BUS 162329 [AJMER42 220.00] CKT 2	233	325	315	103.14	SC-8
330.	164409 HINDAU-4 400.00 162207 HINDAU-4 220.00 1	OPEN LINE FROM BUS 164409 [HINDAU-4 400.00] TO BUS 162207 [HINDAU-4 220.00] CKT 2	217	321	315	101.97	SC-8
331.	174265 REWA 400.00 172112 REWAROAD 220.00 1	OPEN LINE FROM BUS 177262 [MAINPURIUP 765.00] TO BUS 177263 [BARA 765.00] CKT 1	278	321	315	101.85	SC-8
332.	364039 MANDSAUR-4 400.00 362113 MANDSOUR-42 220.00 1	OPEN LINE FROM BUS 364039 [MANDSAUR-4 400.00] TO BUS 362113 [MANDSOUR-42 220.00] CKT 2	226	321	315	101.8	SC-8
333.	444012 KOLAGHAT 400.00 442012 KTPS220 220.00 1	OPEN LINE FROM BUS 444012 [KOLAGHAT 400.00] TO BUS 442012 [KTPS220 220.00] CKT 2	213	316	315	100.29	SC-8
334.	164400 MERTA 400.00 162200 MERTA-42 220.00 1	OPEN LINE FROM BUS 164400 [MERTA 400.00] TO BUS 162200 [MERTA-42 220.00] CKT 2	226	315	315	100.1	SC-8
335.	174472 OBRA4 400.00 172062 OBRA2 220.00 3	OPEN LINE FROM BUS 174472 [OBRA4 400.00] TO BUS 172062 [OBRA2 220.00] CKT 1	185	238	240	99.28	SC-8

S. No.	Monitored Element	Contingency	Base Flow	Maximum Flow	Rate	% loading	Scenario
336.	444422 DURGAPUR-B 400.00 442682 DURGAPUR-A 220.00 1	OPEN LINE FROM BUS 444422 [DURGAPUR-B 400.00] TO BUS 442682 [DURGAPUR-A 220.00] CKT 2	247	312	315	99.18	SC-8
337.	164420 KOTA 400.00 162919 KOTA 220.00 1	OPEN LINE FROM BUS 164420 [KOTA 400.00] TO BUS 162919 [KOTA 220.00] CKT 2	241	310	315	98.51	SC-8
338.	454001 DURGAPUR TPS400.00 452001 DURGAPUR TPS220.00 1	OPEN LINE FROM BUS 454001 [DURGAPUR TPS400.00] TO BUS 452001 [DURGAPUR TPS220.00] CKT 2	330	472	500	94.3	SC-8
339.	454002 MEJIA-B 400.00 452002 MEJIA-B 220.00 1	OPEN LINE FROM BUS 454002 [MEJIA-B 400.00] TO BUS 452002 [MEJIA-B 220.00] CKT 2	218	297	315	94.23	SC-8
340.	374043 AURANG-CHTPM400.00 372340 PG-AURANGABD220.00 1	OPEN LINE FROM BUS 374043 [AURANG-CHTPM400.00] TO BUS 372340 [PG-AURANGABD220.00] CKT 2	209	290	315	92.19	SC-8
341.	484002 BOKARO-A 400.00 482001 BOKARO TPS 220.00 1	OPEN LINE FROM BUS 484002 [BOKARO-A 400.00] TO BUS 482001 [BOKARO TPS 220.00] CKT 2	295	453	500	90.62	SC-8
342.	544004 TRICHY 400.00 542048 ALUNDR42 230.00 1	OPEN LINE FROM BUS 544004 [TRICHY 400.00] TO BUS 542048 [ALUNDR42 230.00] CKT 3	202	284	315	90.26	SC-8
343.	424014 DUBURI 400.00 422564 DUBRI NEW 220.00 1	OPEN LINE FROM BUS 424014 [DUBURI 400.00] TO BUS 422564 [DUBRI NEW 220.00] CKT 2	246	339	315	107.56	SC-9
344.	324002 MAGARWADA-DD400.00 322002 MAGARWADA 220.00 1	OPEN LINE FROM BUS 324002 [MAGARWADA-DD400.00] TO BUS 322002 [MAGARWADA 220.00] CKT 2	150	303	315	96.12	SC-9

Page intentionally left blank.

Annex 2.8

765kV Buses Exceeding Design Fault Current

Area	Bus Name	Sc-1	Sc-2	Sc-3	Sc-4	Sc-5	Sc-6	Sc-7	Sc-8	Sc-9	Max	Design Level	Remark
NORTH	JAIPUR	38	44	44	36	43	44	42	45	45	45	40	STU
NORTH	GNOIDAUP	38	44	43	36	44	44	40	43	43	44	40	STU
NORTH	ALIGARH	41	46	46	38	46	47	43	46	46	47	40	ISTS
WEST	BLPSR WR	38	43	43	35	42	43	44	44	44	44	40	ISTS
WEST	GWALIOR	39	43	42	37	41	43	41	42	43	43	40	ISTS
WEST	JABALPR-POOL	46	52	52	43	51	52	52	53	53	53	50	ISTS
WEST	WARDHA	41	43	43	39	42	43	43	43	44	44	40	ISTS
SOUTH	CUDP800	39	41	42	39	42	42	42	43	43	43	40	ISTS
SOUTH	KURL800	50	50	51	48	50	51	52	52	52	52	40	ISTS
SOUTH	MAHESHWARAM	48	48	49	47	48	49	51	50	51	51	40	ISTS
SOUTH	NIZAMABAD	41	42	43	40	42	43	44	44	44	44	40	ISTS

- Highlighted cell indicates 765 kV Bus Fault Current > Design level

400kV Buses Exceeding Design Fault Current

Area	Bus Name	Sc-1	Sc-2	Sc-3	Sc-4	Sc-5	Sc-6	Sc-7	Sc-8	Sc-9	Max	Design Level	Remark
NORTH	NAKODAR4	38	44	44	36	44	43	38	43	44	44	40	STU
NORTH	PATIALA4	45	48	48	43	48	48	45	48	48	48	40	ISTS
NORTH	JALANDHAR4	41	45	45	40	45	45	41	45	45	45	40	ISTS
NORTH	SONAROAD	38	43	42	36	41	42	39	42	42	43	40	STU
NORTH	DAULATABAD4	43	52	51	41	50	51	45	51	51	52	40	STU
NORTH	JHAJAR_N	38	48	48	36	47	48	39	48	48	48	40	GEN
NORTH	KABULPUR	38	46	45	36	45	45	40	45	45	46	40	STU
NORTH	DHANONDA	48	59	58	45	58	58	50	58	58	59	40	STU
NORTH	GURGAON	45	53	52	43	51	52	47	52	52	53	50	ISTS
NORTH	PANCHKULA-PG	44	47	47	43	47	47	45	47	48	48	40	ISTS
NORTH	BHIWANI-PG	49	55	54	46	54	54	51	54	54	55	50	ISTS
NORTH	ABDULLAP	47	52	52	46	51	52	48	51	52	52	40	ISTS
NORTH	KAITHAL	38	42	41	37	41	41	39	41	42	42	40	ISTS
NORTH	BALLABHG	44	50	49	42	49	50	46	49	49	50	40	ISTS
NORTH	BAWANA-G	42	54	53	40	53	53	43	52	51	54	40	STU
NORTH	BAWANA	42	54	53	40	54	53	44	53	51	54	40	STU
NORTH	MANDOLA	39	46	45	37	44	45	40	45	45	46	40	ISTS
NORTH	MUNDKA	35	42	42	33	41	42	36	41	41	42	40	STU
NORTH	MANDOLASP2	39	46	45	37	44	45	40	45	45	46	40	ISTS
NORTH	MANDOLASP3	39	46	45	37	44	45	40	45	45	46	40	ISTS
NORTH	TUGHLAKABAD	37	42	41	35	40	41	39	41	41	42	40	ISTS
NORTH	GOPAL PUR	40	46	45	37	45	46	41	45	46	46	40	STU
NORTH	JHATIKARASP	38	43	41	35	41	42	39	41	42	43	40	ISTS

Area	Bus Name	Sc-1	Sc-2	Sc-3	Sc-4	Sc-5	Sc-6	Sc-7	Sc-8	Sc-9	Max	Design Level	Remark
NORTH	BHADLA	41	40	39	39	38	39	43	39	39	43	40	STU
NORTH	BASSI	47	52	50	44	50	51	50	51	52	52	40	ISTS
NORTH	NEEMR-PG	48	56	55	45	54	55	50	55	55	56	40	ISTS
NORTH	SIKAR	38	45	43	36	43	44	42	44	44	45	40	ISTS
NORTH	JAIPUR_RS	48	54	52	45	52	53	51	53	54	54	40	STU
NORTH	BIKANER-NW	56	52	50	54	50	51	57	51	51	57	40	ISTS
NORTH	FATEHG-2	53	45	45	52	44	45	55	45	45	55	50	ISTS
NORTH	FATEHG-3	55	53	52	54	51	52	56	52	53	56	40	ISTS
NORTH	BIKANER-II	53	46	45	52	44	45	54	45	45	54	40	ISTS
NORTH	BHADLA-2	52	46	45	49	45	46	53	46	46	53	50	ISTS
NORTH	BHIWADI	44	52	50	41	50	51	47	50	51	52	40	ISTS
NORTH	DAUSA	42	37	36	40	36	37	44	36	37	44	40	ISTS
NORTH	MEJA	42	49	49	35	48	49	48	48	49	49	40	GEN
NORTH	MAINPURIUP	39	42	41	37	41	42	40	41	41	42	40	STU
NORTH	BARA	41	45	45	32	45	45	44	44	45	45	40	STU
NORTH	GNOIDAUP	52	60	59	49	59	60	55	59	59	60	40	STU
NORTH	HAPUR	40	44	43	38	42	43	41	43	43	44	40	STU
NORTH	GAZIABAD	41	45	44	39	43	44	42	44	44	45	40	STU
NORTH	UNNAO4	41	43	43	39	42	43	42	43	43	43	40	STU
NORTH	SIKANDERABAD	38	44	43	37	43	44	41	43	44	44	40	STU
NORTH	BAREL-PG	49	53	52	46	51	52	51	52	53	53	50	ISTS
NORTH	AGRANEW	41	44	43	38	44	45	42	44	44	45	40	STU
NORTH	DADR-NCR	46	60	59	44	59	59	48	59	59	60	40	GEN
NORTH	GNOIDA4	49	59	58	47	58	59	52	58	58	59	40	STU
NORTH	LUCK4-PG	52	55	54	48	53	54	53	55	55	55	40	ISTS

Area	Bus Name	Sc-1	Sc-2	Sc-3	Sc-4	Sc-5	Sc-6	Sc-7	Sc-8	Sc-9	Max	Design Level	Remark
NORTH	LUCK74-P	50	53	52	46	51	52	51	53	53	53	40	ISTS
NORTH	DADR-HVD	46	59	58	43	58	58	47	58	58	59	40	GEN
NORTH	ANPARA4	51	53	53	48	53	53	53	53	53	53	40	GEN
NORTH	ANPARA-D	45	47	47	43	47	47	47	47	47	47	40	GEN
NORTH	ANPARAC	50	52	52	47	52	52	52	52	52	52	40	GEN
NORTH	ALLAHABA	47	51	51	42	50	51	50	51	51	51	40	ISTS
NORTH	BAL74-PG	44	47	47	41	46	46	45	48	48	48	40	ISTS
NORTH	SARNATH4	42	44	44	40	43	44	43	44	44	44	40	STU
NORTH	ALIGARH	38	43	42	36	42	43	41	42	42	43	40	ISTS
NORTH	MEERUT	59	67	66	57	66	66	61	66	66	67	40	ISTS
NORTH	AGRA	52	58	56	49	56	57	54	57	57	58	40	STU
NORTH	SINGRL4	42	43	43	41	43	43	43	43	43	43	40	GEN
NORTH	TIKRI KHURD	38	47	47	36	47	47	39	46	45	47	40	STU
WEST	JINDAL_EX	43	44	45	39	44	45	45	45	46	46	40	GEN
WEST	BIL-POOL	38	46	47	36	46	47	47	47	47	47	40	ISTS
WEST	SOJA4	35	37	37	34	36	36	37	42	42	42	40	STU
WEST	MUNDRA-APL	22	23	23	22	22	22	40	42	42	42	40	GEN
WEST	CGPL	45	45	45	27	45	45	45	45	45	45	40	GEN
WEST	VADODARA	48	52	52	47	51	51	49	53	53	53	50	ISTS
WEST	BINA-4	40	43	43	38	42	43	43	43	43	43	40	STU
WEST	NAGDA-4	42	43	43	41	43	43	43	44	44	44	40	STU
WEST	JABALPUR-4	37	41	41	34	41	41	41	43	43	43	40	ISTS
WEST	BINA-PG-74	40	43	43	39	42	43	43	43	43	43	40	ISTS
WEST	CHANDRAPUR I	24	40	41	24	38	39	44	45	46	46	40	GEN
WEST	AURANGBD-I	42	44	45	42	44	44	44	44	45	45	40	STU

Area	Bus Name	Sc-1	Sc-2	Sc-3	Sc-4	Sc-5	Sc-6	Sc-7	Sc-8	Sc-9	Max	Design Level	Remark
WEST	TAPS4	45	47	48	45	47	47	45	47	47	48	40	GEN
WEST	BOISAR	44	46	47	44	46	46	44	46	47	47	40	ISTS
WEST	CHANDRPR-II	24	40	41	24	38	39	44	45	46	46	40	GEN
WEST	PUNE-PG-GIS	50	52	53	50	52	52	51	52	53	53	50	ISTS
WEST	AURANGABD-II	41	43	44	41	42	43	43	43	44	44	40	STU
WEST	AURANGBD-III	39	41	43	39	41	41	42	41	42	43	40	STU
WEST	CHNDPUR_SW	23	38	39	23	37	37	43	43	44	44	40	GEN
EAST	RANCHI	42	46	45	38	45	45	45	48	46	48	40	ISTS
SOUTH	KURNOOL4	52	51	51	51	51	52	52	52	53	53	40	STU
SOUTH	VEMAGIR4	36	45	45	36	45	46	38	46	46	46	40	STU
SOUTH	KURL-NEW	54	54	54	53	53	54	54	54	55	55	50	ISTS
SOUTH	HYDERABAD	37	39	39	36	39	39	42	42	42	42	40	ISTS
SOUTH	DICHPAL4	47	49	49	46	48	49	52	51	52	52	40	STU
SOUTH	GAJWEL4	36	39	39	34	39	39	42	42	42	42	40	STU
SOUTH	NELMANG4	42	43	43	42	42	43	44	43	44	44	40	STU
SOUTH	UDMP	46	47	47	46	48	48	46	49	50	50	40	ISTS
SOUTH	PUGALUR4	39	40	40	38	42	42	39	42	43	43	40	ISTS
SOUTH	TIRUNEL4	52	51	51	51	52	52	52	55	56	56	40	ISTS

Highlighted cell indicates 400 kV Bus Fault Current > Design level

Page intentionally left blank.

Annex 2.9

ISTS Network Expansion Plan upto 2027-28

1. Transmission lines

Sl. No.	Time Frame	Region	Transmission Line	Voltage level (kV)	S/c, D/c, M/c	Line length (ckm)	From end reactor	To end reactor
1.	2022-23	NR	Mohindergarh – Bhiwani 400kV D/c Line	400	D/c	122		
2.	2022-23	NR	220kV D/c line from UT Chandigarh to 400/220kV Panchkula(PG) substati	220	D/c	50		
3.	2022-23	NER	Roing (POWERGRID) – Chapakhowa (AEGCL) 132kV D/c line along with assooiated bays	132	D/c	67		
4.	2022-23	NER	LILo of Palatana – Surajmaninagar (ISTS) 400kV D/c line at 400/132kV Surajmaninagar (TSECL) S/ s along with associated 4 no. 400kV line bays – In matching timeframe of upgradation of 400/132kV Surajmaninagar (TSECL) substation	400	D/c	12		
5.	2022-23	NER	Installation of 400kV, 2x63MVar switchable line reactors, one in each circuit of Silchar (POWERGRID) – Imphal (POWERGRID) 400kV D/c line at Imphal end	400				126
6.	2022-23	NER	Lower Subansiri – Biswanath Chariyali 400kV 2 x D/c (Twin Lapwing) line (341.5km): Matching with Lower Subansiri (2000MW) HEP	400	D/c	730		
7.	2023-24	WR	Xeldem – Mapusa 400kV D/c (quad) line -80ckm	400	D/c	109.6		
8.	2023-24	WR	Xeldem (existing) - Xeldem (new) 220kV D/c line	220	D/c	40		
9.	2023-24	WR	Khavda PS 1(GIS) – Bhuj PS 765 kV D/c line (120ckm)	765	D/c	120		
10.	2023-24	WR	Warora pool (Maharashtra) – Warangal(New) (Telangana) 765 kV D/c line	765	D/c	664	240	240
11.	2023-24	WR	Neemuch PS – Chhittorgarh (PG) S/s 400 kV D/C line (conductor with minimum capacity of 2100 MVA/Ckt at nominal voltage)	400	D/c	260		
12.	2023-24	WR	Neemuch PS- Mandasaur S/stn 400 kV D/c line (conductor with	400	D/c	240		

Sl. No.	Time Frame	Region	Transmission Line	Voltage level (kV)	S/c, D/c, M/c	Line length (ckm)	From end reactor	To end reactor
			minimum capacity of 2100 MVA/Ckt at nominal voltage)					
13.	2023-24	WR	Pachora SEZ PP -Bhopal (Sterlite) 400 kV D/c line (Quad/HTLS) (320ckm) (with minimum capacity of 2100 MVA/ckt at nominal voltage) along with 80MVAR switchable line reactors on each circuit at Pachora end	400	D/c	320	80	
14.	2023-24	WR	LILO of both circuits of Parli (PG) – Pune (GIS) 400kV D/c line at Kallam PS (40ckm)	400	2xD/c	40		
15.	2023-24	WR	Provision of new 50MVAR switchable line reactor at Kallam PS end of Kallam – Pune(GIS) 400kV D/c line	400			50	
16.	2023-24	WR	LILO of KAPP – Vapi 400kV D/c line at Vapi-II	400	2xD/c	24		
17.	2023-24	WR	Vapi II – Sayali 220kV D/c line	220	D/c	44		
18.	2023-24	WR	Navsari (new) (South Gujarat) (GIS)- Kala (GIS) 400 kV D/c line (conductor with minimum capacity of 2100 MVA/Ckt at nominal voltage) with 63MVAR switchable line reactor on each ckt at Navsari (new) (GIS) end.	400	D/c	220	63	0
19.	2023-24	WR	Navsari(New) (South Gujarat) (GIS) – Magarwada (GIS) 400 kV D/c line (conductor with minimum capacity of 2100 MVA/Ckt at nominal voltage)	400	D/c	160	0	0
20.	2023-24	WR	Navsari (New) (South Gujarat) (GIS) – Padghe (GIS) 765 kV D/c line with 330 MVAR, 765 kV Switchable line reactor on each ckt at Navsari(New) (South Gujarat) end	765	D/c	400	330	0
21.	2023-24	SR	Warangal (New) –Hyderabad 765 kV D/c line	765	D/c	268	240	
22.	2023-24	SR	Warangal (New) – Warangal (Existing) 400 kV (quad) D/c line	400	D/c	96		
23.	2023-24	SR	Hyderabad – Kurnool 765 kV D/c line.	765	D/c	337		240
24.	2023-24	SR	Warangal (New) – Chilakaluripeta 765kV D/c line	765	D/c	390	240	240
25.	2023-24	SR	NNTPS Switchyard - Ariyalur (Villupuram) 400kV D/c line	400	D/c	148		
26.	2023-24	SR	Pooling station (near Munirabad /suitable location in Koppal distt.) - Narendra (New)	400	D/c	250		

Sl. No.	Time Frame	Region	Transmission Line	Voltage level (kV)	S/c, D/c, M/c	Line length (ckm)	From end reactor	To end reactor
			GIS 400 kV D/c Line (with Quad Moose ACSR conductor)					
27.	2023-24	SR	Gadag PS - Narendra (New) PS 400 kV (high capacity equivalent to quad moose) D/C Line	400	D/c	200		
28.	2023-24	SR	Gadag PS - Koppal PS 400 kV (high capacity equivalent to quad moose) D/C Line	400	D/c	120		
29.	2023-24	SR	LILO of both circuits of Pugalur – Pugalur (HVDC) 400 kV D/c line (with Quad Moose ACSR Conductor) at Karur PS	400	D/c	100		
30.	2023-24	NR	Koteshwar Pooling Station - Rishikesh 400kV D/C (twin) line	400	D/c	83		
31.	2023-24	NR	Babai (RRVPLN) – Bhiwani (PG) 400kV D/C line	400	D/c	221		
32.	2023-24	NR	Removal of LILO of one circuit of Bhadla-Bikaner (RVPN) 400kV D/C line at Bikaner (PG) & Extension of this LILO section from Bikaner (PG) to Bikaner-II PS to form Bikaner-II PS-Bikaner (PG) 400kV D/C line	400	D/c	64		
33.	2023-24	NR	Removal of LILO of Bawana – Mandola 400kV D/c (Quad) line at Maharani Bagh /Gopalpur S/s. Extension of above LILO section from Maharani Bagh/ Gopalpur upto Narela S/s so as to form Maharani Bagh – Narela 400kV D/c(Quad) and Maharani Bagh-Gopalpur-Narela 400kV D/c (Quad) lines	400	D/c	28		
34.	2023-24	NR	Fatehgarh-III - Fatehgarh-II 400kV D/c line (Twin HTLS)	400	D/c	88		
35.	2023-24	NR	Fatehgarh-III - Jaisalmer-II (RVPN) 400kV D/c line (Twin HTLS)	400	D/c	100		
36.	2023-24	NR	Bikaner-II PS – Khetri 400kV 2xD/c line (Twin HTLS line on M/c tower)	400	D/c	1088	80	
37.	2023-24	NR	Khetri - Bhiwadi 400kV D/c line (Twin HTLS)	400	D/c	236		
38.	2023-24	NR	Fatehgarh II - Bhadla II 765kV D/C Line (2nd)	765	D/c	375	240	240
39.	2023-24	NR	Bhadla II - Sikar II 765 kV D/C line	765	D/c	612	240	330
40.	2023-24	NR	Sikar II - Neemrana 400kV D/c line (Twin HTLS)	400	D/c	274		
41.	2023-24	NR	Sikar-II - Aligarh 765kV D/C Line	765	D/c	408	330	330
42.	2023-24	NR	Khetri – Narela 765 kV D/c line	765	D/c	180		330

Sl. No.	Time Frame	Region	Transmission Line	Voltage level (kV)	S/c, D/c, M/c	Line length (ckm)	From end reactor	To end reactor
43.	2023-24	NR	LILO of 765 kV MeerutBhiwani S/c line at Narela	765	D/c	50		
44.	2023-24	NER	Pare HEP (NEEPCO, Ar. Pradesh) – North Lakhimpur (AEGCL) 132kV D/c line with one circuit via Nirjuli (POWERGRID) (with ACSR Zebra conductor) – (55km)	132	D/c	110		
45.	2023-24	NER	Bongaigaon (POWERGRID) – Nangalbibra 400kV D/c line (initially operated at 220kV) – 280ckm	400	D/c	280		
46.	2023-24	NER	Hatsinghari (Assam) – Ampati (Meghalaya) 132kV D/c line – 60 ckm	132	D/c	60		
47.	2023-24	ER	Installation of 400kV, 2x63MVAR switchable line reactors, one in each circuit of Kahalgaon - Durgapur 400kV D/c line	400	D/c		126	
48.	2023-24	ER	Sitamarhi (POWERGRID) - Dhalkebar (Nepal) 400kV D/c (Quad) line (Indian portion) – 80ckm	400	D/c	80		
49.	2023-24	ER	Installation of 420kV, 63 MVAR switchable line reactor with 5000hm NGR at Kahalagaon (NTPC) end, one each in both circuits of Kahalgaon(NTPC) – Durgapur (POWERGRID) 400kV D/c line.	400kV	D/c		126	
50.	2024-25	WR	LILO of Apta – Kalwa/Taloja 220kV D/c line (i.e. Apta – Kalwa and Apta – Taloja 220kV lines) at Navi Mumbai (PG)- 2km	220	2xD/c	4		
51.	2024-25	WR	LILO of one ckt. of KPS1- Bhuj PS 765 kV D/c line at KPS2	765	D/c			
52.	2024-25	WR	KPS1-Khavda PS GIS (KPS2) 765 kV D/C line (to be established with bypassing of LILO of one ckt. of KPS1-Bhuj at KPS2 and utilisation of LILO section) - 20Km	765	D/c	40		
53.	2024-25	WR	Padghe (PG) – Kharghar 400kV D/c (quad) line to be terminated into one ckt. of Kharghar – Ghatkopar 400kV D/c (quad) line (thus forming Padghe (PG) – Kharghar 400kV S/c (quad) line, Padghe (PG) –	400	D/c	120		

Sl. No.	Time Frame	Region	Transmission Line	Voltage level (kV)	S/c, D/c, M/c	Line length (ckm)	From end reactor	To end reactor
			Ghatkopar 400kV S/c (quad line) - 60km					
54.	2024-25	WR	LILO of Padghe (PG) – Ghatkopar 400kV S/c line at Navi Mumbai GIS (PG) (with quad conductor) - 10km	400	D/c	20		
55.	2024-25	WR	LILO of Satna - Bina 400 kV (1st) D/c line at Chhatarpur PS*~ 60 km *out of Satna – Bina 2xD/c lines, one circuit of 2nd D/c line has been LILoed at Sagar (MPPTCL) substation. The proposed LILO is to be made on the other (1st) D/c line between Satna & Bina.	400	2xD/c	240		
56.	2024-25	WR	Jeypore – Jagdalpur 400kV D/c line (conductor with minimum capacity of 2100 MVA/Ckt at nominal voltage) along with associated bays at both ends	400	D/c	160	0	0
57.	2024-25	WR	Raipur Pool – Dhamtari 400 kV D/c line (conductor with minimum capacity of 2100 MVA/Ckt at nominal voltage) along with associated bays at both ends	400	D/c	160	0	0
58.	2024-25	WR	KPS3- KPS2 765 kV D/c line - 20km	765	D/c	40		
59.	2024-25	WR	KPS2 (GIS) – Lakadia 765 kV D/C line with 330 MVar switchable line reactors at KPS2 end - 159KM	765	D/c	320	330	
60.	2024-25	WR	Ahmedabad – South Gujarat/Navsari (new) 765 kV D/c line with 240 MVar switchable line reactor at both ends (~line length 220 km)	765	D/c	440	240	240
61.	2024-25	WR	Lakadia PS – Ahmedabad 765kV D/c line with 240 MVAR switchable line reactors on both ends (500ckm)	765	D/c	500	240	240
62.	2024-25	WR	LILO of Pirana (PG) – Pirana (T) 400kV D/c line at Ahmedabad S/s with twin HTLS along with reconductoring of Pirana (PG) – Pirana(T) line with twin HTLS conductor	400	D/c	88		
63.	2024-25	WR	Banaskantha – Sankhari 400 kV 2 nd D/c line	400	D/c	52	0	0

Sl. No.	Time Frame	Region	Transmission Line	Voltage level (kV)	S/c, D/c, M/c	Line length (ckm)	From end reactor	To end reactor
64.	2024-25	WR	Banaskantha – Ahmedabad 765 kV D/c line with 330MVAR, 765 kV Switchable line reactor on each ckt at Ahmedabad S/s end	765	D/c	400	0	330
65.	2025-26	WR	Solapur pooling point - Solapur (PG) 400 kV D/c line (twin HTLS) (with minimum capacity of 2100 MVA/ckt at nominal voltage) - 50KM	400	D/c	100		
66.	2024-25	SR	Mangalore (Udupi PCL) – Kasargode 400kV (Quad) D/c line	400	D/c	231		
67.	2024-25	SR	Narendra New (GIS) - Pune (GIS) 765 kV D/c line with 1x330 MVAR switchable Line Reactor on each circuit at both end	765	D/c	680	330	330
68.	2024-25	SR	Kurnool-III Pooling station - Kurnool (new) 765 kV D/c Line	765	D/c	200		
69.	2024-25	SR	Kurnool-III Pooling station - Maheshwaram(PG) 765 kV D/c Line	765	D/c	500	240	240
70.	2024-25	NR	Bhadla II - Sikar II 765 kV D/C line (2nd)	765	D/c	620	240	330
71.	2024-25	NR	400 kV D/c Khandukhal(Srinagar) - Rampura (Kashipur) line (Twin HTLS*)	400	D/c	390		80
72.	2024-25	NR	Laying of cable about 15km provided between Minamarg and Zojila Top section of Alusteng –Drass 220kV section	220	S/c	15		
73.	2024-25	NR	Fatehgarh-4- Fatehgarh-3 400 kV D/c twin HLTS line	400	D/c	100		
74.	2024-25	NR	Fatehgarh 3- Bhadla-3 400kV D/c line(Quad)	400	D/c	400	50	50
75.	2024-25	NR	Fatehgarh-2 – Bhadla-3 400kV D/c line (Quad)	400	D/c	400	50	50
76.	2024-25	NR	Bhadla-3 – Sikar-II 765 kV D/c line	765	D/c	760	330	330
77.	2024-25	NR	Ramgarh – Bhadla-3 765kV D/c line	765	D/c	360	240	
78.	2024-25	NR	Sikar-II – Khetri 765 kV D/c line	765	D/c	180		
79.	2024-25	NR	Sikar-II – Narela 765 kV D/c line	765	D/c	520	240	340
80.	2024-25	NR	Jhatikara – Dwarka 400kV D/c line	400	D/c	40		
81.	2024-25	NR	LILO of both circuit of Ajmer- Chittorgarh 765 kV D/c at Beawar	765	D/c	180		
82.	2024-25	NR	LILO of 400kV Kota –Merta line at Beawar	400	S/c	40		

Sl. No.	Time Frame	Region	Transmission Line	Voltage level (kV)	S/c, D/c, M/c	Line length (ckm)	From end reactor	To end reactor
83.	2024-25	NR	Fatehgarh-3– Beawar 765 kV D/c	765	D/c	350	330	330
84.	2024-25	NR	Fatehgarh-3– Beawar 765 kV D/c(2nd)	765	D/c	700	330	330
85.	2024-25	NR	LILO of both circuits of Jaipur (Phagi)- Gwalior 765 kV D/c at Dausa	765	D/c	160		240
86.	2024-25	NR	LILO of both circuits of Agra – Jaipur (South) 400kV D/c at Dausa	400	D/c	120		50
87.	2024-25	NR	Beawar – Dausa 765 kV D/c line	765	D/c	480	240	240
88.	2024-25	ER	NKSTPP – Jharkhand Pool 400kV D/c (quad) line (50ckm)	400	D/c	50		
89.	2024-25	ER	NKSTPP – Gaya 400kV D/c (quad) line (185ckm)	400	D/c	185		
90.	2025-26	WR	LILO of one ckt. of Narendra (existing) – Narendra (New) 400kV D/c quad line at Xeldem -240ckm	400	D/c	187.35		
91.	2025-26	WR	LILO of Wardha - Warora Pool 400 kV D/c (Quad) line at Wardha SEZ PP - 85KM	400	2xD/c	340		
92.	2025-26	WR	Dholera PS – Vataman switching station 765 kV D/C line – 40 km.	765	D/c	80		
93.	2025-26	SR	Bidar PS – Maheshwaram (PG) 765kV D/C line along with 1x240 MVAR switchable Line Reactor on Bidar end of both ckts	765	D/c	320	240	0
94.	2025-26	SR	Ananthapuram PS - Kurnool-III PS 400 kV (High capacity equivalent to quad moose) D/c Line	400	D/c	200		
95.	2025-26	SR	Anantapuram PS - Cuddapah 400 kV (High capacity equivalent to quad moose) D/c Line with 80 MVAR switchable line reactor on Ananthapuram PS end of each circuit	400	D/c	300	80	0
96.	2025-26	SR	Upgradation/charging of Tuticorin PS - Dharmapuri (Salem New) 765 kV D/c line (initially charged at 400 kV) to its rated voltage of 765 kV along with 1x330 MVAR switchable Line Reactor on both end of each circuit	765	D/c		330	330
97.	2025-26	SR	Upgradation/charging of Dharmapuri (Salem New) - Madhugiri (Tumkur) 765 kV 2xS/c line (initially charged at	765	2XS/c		330	

Sl. No.	Time Frame	Region	Transmission Line	Voltage level (kV)	S/c, D/c, M/c	Line length (ckm)	From end reactor	To end reactor
			400 kV) to its rated voltage of 765 kV along with 1x330 MVAR switchable Line Reactor on Dharampuri (Salem New) end of both ckts					
98.	2025-26	SR	Upgradation/charging of Madhugiri (Tumkur) - Narendra New 765 kV D/c line (initially charged at 400 kV) to its rated voltage of 765 kV along with 1x330 MVAR switchable Line Reactor on both end of each circuit	765	D/c		330	330
99.	2025-26	SR	Koppal-II - Narendra New 765kV D/c line with 240 MVAR SLR at Koppal-II PS end	765kV	D/c	150	240	
100.	2025-26	SR	Gadag-II PS - Koppal-II PS 400kV (Quad Moose) D/c line	400kV	D/c	100		
101.	2025-26	SR	Koppal-II - Raichur 765kV D/c linw with 330 MVAR SLR at Koppal-II PS end	765kV	D/c	190	240	
102.	2025-26	NR	LILO of one circuit of Kishenpur – Dulhasti 400kV D/c (Quad) line	400	D/c	20		
103.	2025-26	NR	Stringing of 2 nd circuit of Kishenpur – Dulhasti 400kV D/c line (Kishtwar – Kishenpur Section)	400	D/c	130		
104.	2025-26	NR	LILO of both 400 kV D/c Amargarh - Samba line at 400/220 kV Siot S/s	400	D/c	30		
105.	2025-26	NR	Nange (GIS) Pooling Station – Koldam 400 kV D/c line (Triple snowbird)	400kV	D/c	80		
106.	2025-26	NR	Bypassing one ckt of Koldam – Ropar/Ludhiana 400kV D/c line (Triple snowbird) at Koldam and connecting it with one of the circuit of Nange- Koldam 400kV D/c line(Triple snowbird), thus forming Nange- Ropar/ Ludhiana one line (Triple snowbird)	400kV	S/c	0		50
107.	2025-26	NER	Kathalguri (NEEPCO) – Namsai (POWERGRID) 220kV D/c line	220	D/c	150		
108.	2025-26	NER	Gogamukh - Gerukamukh 132kV D/c line	132	D/c	40		
109.	2025-26	NER	LILO of one D/c (ckt-1 & ckt-2 of line-1) of Lower Subansiri – Biswanath Chariali 400kV (Twin Lapwing) 2xD/c lines at Gogamukh S/s	400	D/c	40		

Sl. No.	Time Frame	Region	Transmission Line	Voltage level (kV)	S/c, D/c, M/c	Line length (ckm)	From end reactor	To end reactor
110.	2026-27	NR	Kaza-Wangtoo (HPPTCL) 400 kV D/c (Quad) line	400kV	D/c	360	80	
111.	2026-27	NR	Wangtoo (HPPTCL) - Panchkula (PG) 400 kV D/c (Twin HTLS)	400kV	D/c	420		80
112.	2026-27	NR	Bhadla-3 - Bhadla(HVDC) 400kV 2xD/c quad moose line(2km)	400	D/c	4		
113.	2026-27	NR	±800KV HVDC line (Hexa lapwing)(4x1500 MW) between Bhadla-3 & Fatehpur (950km) with DMR.	800(HVDC)	D/c	1900		
114.	2026-27	NR	LILO of both ckts of 765kV Varanasi – Kanpur (GIS) D/c at Fatehpur(30km)	765	D/c	60		
115.	2026-27	NR	400kV Kishenpur Kishtwar D/c (2nd) (Quad)	400kV	D/c	260		
116.	2026-27	NR	400kV New Wanpoh - Samba D/c (existing) line (bypassing of 400kV New Wanpoh – Kishenpur D/c & Samba – Kishenpur D/c at Kishenpur)	400kV	D/c	0		
117.	2027-28	NR	400kV PS-1 - Pang D/c (quad moose) line	400	D/c	14		
118.	2027-28	NR	400kV PS-2 -Pang D/c (quad moose) line	400	D/c	54		
119.	2027-28	NR	400kV PS-3 -Pang D/c (quad moose) line	400	D/c	82		
120.	2027-28	NR	220kV Pang – Leh (Phyang) S/c line (Deer conductor) (S/c line on D/c tower)	220	S/c	158		
121.	2027-28	NR	Kaithal – Bahadurgarh (PG) 400 kV D/c Line (Twin HTLS)	400	D/c	340		
122.	2027-28	NR	Kaithal-Modipuram (Meerut) (UPPTCL) 765 kV D/c Line	400	D/c	420		240
123.	2027-28	NR	±350kV HVDC line between Pang & Kaithal PS (combination of 465km overhead line (Quad) and 15 km underground cable)	HVDC (350KV)	D/c	960		
124.	2029-30	NER	Dibang - Gogamukh 400kV 2xD/c line	400kV	2xD/c	860	252	252
125.	2029-30	NER	Gogamukh- Lower Subansiri 400kV D/c line	400kV	D/c	350	160	
126.	#N/A	#N/A	Jeerat- Subhasgram 400kV D/c (Q) line	400	D/c	214		
127.								
128.	2025-26	NR	LILO of both ckts of 400kV Bikaner (PG)-Bikaner-II D/c line at Bikaner-III PS	400kV	D/c	80		
129.	2025-26	NR	Bikaner-II PS – Bikaner-III PS 400 kV D/c line (Quad)	400kV	D/c	60		
130.	2025-26	NR	LILO of both ckts of 400 kV Sohna Road(GPTL)-	400kV	D/c	340		

Sl. No.	Time Frame	Region	Transmission Line	Voltage level (kV)	S/c, D/c, M/c	Line length (ckm)	From end reactor	To end reactor
			Gurgaon(PG) D/c line at Neemrana-II S/s					
131.	2025-26	NR	Neemrana-II -Kotputli 400 kV D/c line (Quad	400kV	D/c	140		
132.	2025-26	NR	Bikaner-III – Neemrana-II 765 kV 2xD/c line	765kV	D/c	1400	660	660
133.	2025-26	NR	Neemrana-II- Bareilly(PG) 765 kV D/c line	765kV	D/c	700	330	330
134.	2025-26	SR	Davangere/Chitradurga PS - Koppal-II PS 400kV (QM equivalent) D/c line	400kV	D/c	200	-	-
135.	2025-26	SR	Tumkur-II PS - Tumkur (Pavagada) 400kV (QM equivalent) D/c line	400kV	D/c	200	-	-
136.	2025-26	SR	Bijapur PS - Koppal-II PS 400kV (QM equivalent) D/c line	400kV	D/c	200	-	-
137.	2025-26	SR	Nizamabad-II PS - Nizamabad (PG) 765kV 2XD/c line	765kV	D/c	120	-	-
138.	2026-27	SR	Nizamabad-II PS - Warangal (New) 765kV D/c line with 330 MVar SLR at Nizamabad-II PS	765kV	D/c	360	330	-
139.	2025-26	SR	Medak PS - Nizamabad-II 400kV (QM equivalent) D/c line	400kV	D/c	120	-	-
140.	2025-26	SR	Rangareddy PS - Nizamabad-II 400kV (QM equivalent) D/c line with 80 MVar SLR at Rangareddy PS	400kV	D/c	310	80	-
141.	2026-27	SR	Bellary PS - Koppal-II 400kV (QM equivalent) D/c line	400kV	D/c	200	-	-
142.	2026-27	SR	Karimnagar PS - Nizamabad-II 400kV (QM equivalent) D/c line	400kV	D/c	200	-	-
143.	2026-27	SR	Kurnool-IV - Kurnool-III PS 765kV D/c line	765kV	D/c	200		
144.	2026-27	SR	Anantapur-II - Cuddapah 765kV D/c line with 240 MVar SLR at Anantapur-II PS	765kV	D/c	500	240	-
145.	2026-27	SR	Anantapur-II - Kurnool-IV 765kV D/c line	765kV	D/c	200	-	-
146.	2026-27	SR	Kurnool-IV - Bidar PS 765kV D/c line with 240 MVar SLR at both ends	765kV	D/c	560	240	240
147.	2026-27	SR	LILO of both circuits of Anantapur-II - Cuddapah 765kV D/c line at Kadapa-II PS	765kV	D/c	20	-	-
148.	2025-26	SR	Reconductoring of raichur-Veltoor 400kV D/c line with HTLS Conductor	400kV	D/c	0	-	-
149.	2025-26	NR	Fatehgarh-IV (Section-2) PS – Bhinmal (PG) 400 kV D/c line (Twin HTLS)	400kV	D/c	400	50	50
150.	2025-26		LILO of both ckts of 765 kV Fatehgarh-III- Beawar D/c	765kV	D/c	60	330	-

Sl. No.	Time Frame	Region	Transmission Line	Voltage level (kV)	S/c, D/c, M/c	Line length (ckm)	From end reactor	To end reactor
			line(2nd) at Fatehgarh-IV (Section-2) PS along with 330 MVAR switchable line reactors at Fatehgarh-IV PS end of each ckt of 765 kV Fatehgarh-IV-Beawar D/c line (formed after LILO)					
151.	2025-26		Fatehgarh-III (Section-2) PS – Barmer-I PS 400 kV D/c line (Quad)	400kV	D/c	100	-	-
152.	2025-26		Fatehgarh-IV (Section-2) PS – Jalore PS 765 kV D/c line	765kV	D/c	400	240	240
153.	2025-26		Barmer-I PS– Jalore PS 765 kV D/c line	765kV	D/c	330	-	330
154.	2025-26		Jalore PS-Chittorgarh (PG) 400 kV D/c line	400kV	D/c	400	50	50
155.	2025-26		Jalore PS- Mandsaur PS 765 kV D/c line	765kV	D/c	660	330	330
156.	2025-26		Beawar- Mandsaur PS 765 kV D/c line	765kV	D/c	500	240	240
157.	2025-26	ER	Angul - Paradeep 765 kV D/c line	765kV	D/c	380	-	330
158.	2025-26	ER	Paradeep - Paradeep (OPTCL) 400kV D/c (Quad) line	400kV	D/c	20	-	330
159.	2026-27	NR	400 kV Jhangi PS – Wangtoo (Quad) D/c line	400kV	D/c	108	-	-
160.	2026-27	NR	LILO of one circuit of Jhangi PS - Wangtoo (HPPTCL) 400 kV D/c (Quad) line at generation switchyard of Shongtong HEP	400kV	D/c	2	-	-
161.	2026-27	NR	Wangtoo (HPPTCL) - Panchkula (PG) 400 kV D/c (Twin HTLS)	400kV	D/c	420	-	80
162.	2025-26	WR	LILO of Satna-Gwalior 765 kV S/c line at Karera	765	S/c	140	330	
163.	2025-26	WR	LILO of one circuit of Jabalpur - Orai 765 kV D/c line at Ishanagar 765 kV S/s (New)	765	D/c	10		
164.	2025-26	WR	Pachora PS – Ujjain (MPPTCL) 400kV D/c line (Quad ACSR/AAAC/AL59 Moose equivalent)	400	D/c	120		
165.	2025-26	WR	Mandsaur PS – Indore(PG) 765 kV D/c Line (200km) along with 1x330MVAR switchable line reactor (SLR) on each ckt at Mandsaur end	765	D/c	400	330	
166.	2025-26	WR	Mandsaur – Kurawar 765kV D/c line (~235km.) with 240MVAR switchable line reactors (SLRs) at both ends	765	D/c	470	240	240

Sl. No.	Time Frame	Region	Transmission Line	Voltage level (kV)	S/c, D/c, M/c	Line length (ckm)	From end reactor	To end reactor
167.	2025-26	WR	LILO of Indore – Bhopal 765kV 765kV S/c line at Kurawar (LILO length 15km.)	765	S/c	30		
168.	2025-26	WR	Kurawar – Ashtha 400kV D/c (Quad ACSR/AAAC/AL59 moose equivalent) line (65km.)	400	D/c	130		
169.	2025-26	WR	LILO of one circuit of Indore – Itarsi 400kV D/c line at Astha (LILO length 30km.)	400	D/c	60		
170.	2025-26	WR	Shujalpur – Kurawar 400kV D/c (Quad ACSR/AAAC/AL59 moose equivalent) line (40km.)	400	D/c	80		
171.	2025-26	WR	KPS2- Halvad 765 kV D/c line (~220 km length) with 240 MVAR switchable line reactor at both ends and 80 MVAR single phase spare reactor unit at KPS2 end.	765	D/c	440	320	240
172.	2025-26	WR	LILO of Lakadia – Ahmedabad 765 kV D/c line at Halvad (LILO length~50 km)	765	D/c	100		
173.	2025-26	WR	Halvad – Vataman 765 kV D/c line (~170 km length) with 1x330 MVAR switchable line reactor at Vatman end on each ckt	765	D/c	340	330	330
174.	2025-26	WR	LILO of Lakadia – Vadodara 765 kV D/c line at Vataman 765 kV switching station (~10 km LILO length).	765	D/c	40		
175.	2025-26	WR	Vataman switching station – Navsari (New) 765 kV D/c line (~200 km length) with 330MVAR switchable line reactors on each ckt at Navsari (New) end	765	D/c	400		330
176.	2025-26	WR	KPS3 – KPS2 765kV 2nd D/c line (20km.)	765	D/c	40		
177.	2025-26	WR	KPS1 – Bhuj 765kV 2nd D/c line (60km.)	765	D/c	120		
178.	2025-26	WR	KPS2 – Lakadia 765kV 2nd D/c line with 330 MVAR switchable line reactors at KPS2 end of KPS2 (GIS) – Lakadia 765 kV 2nd D/C line	765	D/c	320	330	

Sl. No.	Time Frame	Region	Transmission Line	Voltage level (kV)	S/c, D/c, M/c	Line length (ckm)	From end reactor	To end reactor
			(with NGR bypass arrangement) (160km.)					
179.	2025-26	WR	Vadodara – Navsari(New) 765kV D/c line with 240 MVAR switchable line reactors at Vadodara(GIS) end of Vadodara(GIS) – Navsari(New)(GIS) 765 kV D/C line (with NGR bypass arrangement) (120km.)	765	D/c	240	240	
180.	2025-26	WR	KPS1 – Bhuj 765kV 2nd D/c line (60km.)	765	D/c	120		
181.	2025-26	WR	Navsari(New) – Boisar-II 765kV D/c line with 330 MVAR switchable line reactors at Navsari(New) end of Navsari(New) – Boisar-II 765kV D/c line (with NGR bypass arrangement) (175km.)	765	D/c	350	330	
182.	2025-26	WR	LILO of Navsari(New) – Padghe(PG) 765kV D/c line at Boisar-II (LILO route length 25km.)	765	D/c	50		
183.	2025-26	WR	Boisar-II – Velgaon(MH) 400kV D/c (Quad ACSR/AAAC/AL59 moose equivalent) line (10km.)	400	D/c	20		
184.	2025-26	WR	LILO of Babhaleswar – Padghe(M) 400kV D/c line at Bosar-II using twin HTLS conductor with minimum capacity of 1700MVA per ckt at nominal voltage (LILO route length 65km.) and with 80 MVAR switchable line reactors at Bosar-II end of Boisar-II – Babhaleswar 400kV D/c line (with NGR bypass arrangement)	400	D/c	130	80	
185.	2025-26	WR	Boisar-II – Pune-III 765kV D/c line (200km.) along with 330 MVAR switchable line reactors at Pune-III end of Boisar-II – Pune-III 765kV D/c line (with NGR bypass arrangement).	765	D/c	400		330

Sl. No.	Time Frame	Region	Transmission Line	Voltage level (kV)	S/c, D/c, M/c	Line length (ckm)	From end reactor	To end reactor
186.	2025-26	WR	LILO of Narendra(New) – Pune(GIS) 765kV D/c line at Pune-III (LILO route length 10km.) along with 330 MVAR switchable line reactors at Pune-III end of Narendra(New) – Pune-III(GIS) 765kV D/c line (with NGR bypass arrangement).	765	D/c	20		330
187.	2025-26	WR	LILO of Hinjewadi-Koyna 400kV line at Pune-III(GIS) S/s along with 80MVA, 420kV switchable Line Reactors on each ckt at Pune-III(GIS) end of Pune-III(GIS) – Koyna 400kV line (LILO route length 40km.)	400	D/c	80		80
188.	2026-27	WR	±800 kV HVDC Bipole line between KPS2(HVDC) and Akola-III(HVDC) (1000km.) (with Dedicated Metallic Return) (capable to evacuate 8000MW with overload capacity as specified)	800	D/c	2000		
189.	2026-27	WR	LILO of Wardha – Aurangabad 765kV 2xD/c line at Akola-III (LILO route length 30km.)	765	D/c	120		330
190.	2025-26	WR	LILO of Bhuj-II – Lakadia 765 kV D/c line at Navinal (Mundra) (GIS) S/s with associated bays at Navinal (Mundra) (GIS) S/s along with Installation of 1x330 MVA switchable line reactor on each ckt at Navinal end of Lakadia – Navinal 765 kV D/c line..	765	D/c	280	330	
191.	2025-26	WR	Dhule PS – Dhule (BDTCL) 400 kV D/c Line (Quad Moose) (60 km)	400	D/c	120		

2. Transformers

Sl.No	Timeframe	Region	Transformers	Voltage ratio (kV)	No. of transformer	Rating of transformer (MVA)	Total transformation capacity (MVA)
1.	2022-23	NR	Augmentation with 765/400kV, 1x1500MVA transformer (3rd) at Bhadla-II PS (1500MVA)	765/400	1	1500	1500
2.	2022-23	NR	Creation of 220 kV level at Bhadla-II PS with Installation of 400/220kV, 5x500MVA transformers at Bhadla-II PS (2500MVA)	400/220	5	500	2500
3.	2022-23	NR	Creation of 2x160MVA, 220/66 kV GIS S/s at UT Chandigarh (320MVA)	220/66	2	160	320
4.	2022-23	NR	Augmentation with 400/220kV, 1x500 MVA Transformer (3rd)at Sohawal (PG)	400/220	1	500	500
5.	2022-23	NER	Kopili HEP 220/132kV : 60MVA replacement by 1x160MVA ICT	220/132	1	100	100
6.	2022-23	NER	Installation of 1x100MVA, 220/132kV ICT (3rd) at Salakati alongwith associated bays at both levels	220/132	1	100	100
7.	2022-23	ER	400/220kV, 315MVA (3 rd ICT) at Ranchi New S/s	400/220	1	500	500
8.	2022-23	ER	Shifting of 400kV side of 400/220kV, 315MVA ICT-I from Durgapur-A section to Durgapur-B section without physical shifting of ICT such that all three ICTs are on same 400kV bus section (if required, GIS bus duct could be used)	400/220	0	0	0
9.	2023-24	WR	Establishment of 2x500MVA, 400/220kV substation at Xeldem	400/220	2	500	1000
10.	2023-24	WR	Establishment of Khavda PS1 (KPS1) 765/400kV, 3x1500MVA PS (GIS)	765/400	3	1500	4500
11.	2023-24	WR	Establishment of 2x500 MVA, 400/220 kV Pooling Station (AIS) at Neemuch	400/220	2	500	1000

Sl.No	Timeframe	Region	Transformers	Voltage ratio (kV)	No. of transformer	Rating of transformer (MVA)	Total transformation capacity (MVA)
12.	2023-24	WR	Establishment of 400/220 kV, 3X500 MVA at Pachora SEZ PP	400/220	3	500	1500
13.	2023-24	WR	Establishment of 2x500MVA, 400/220kV at Kallam PS along with 4 nos. 220kV line bays at Kallam PS	400/220	2	500	1000
14.	2023-24	WR	Establishment of 2x500MVA, 400/220kV GIS S/s near Vapi / Ambheti (Vapi-II)	400/220	2	500	1000
15.	2023-24	WR	Augmentation of transformation capacity at Padghe (GIS) 765/400 kV substation by 1x1500 MVA ICT	765/400	1	1500	1500
16.	2023-24	WR	Establishment of 765/400/220 kV Navsari (new) (South Gujarat) S/s (GIS)	765/400	2	1500	3000
17.	2023-24	WR	Establishment of 765/400/220 kV Navsari (new) (South Gujarat) S/s (GIS)	400/220	3	500	1500
18.	2023-24	WR	Augmentation of transformation capacity at Raigarh(Kotra) by 1x1500MVA, 765/400kV ICT at Section-A (3rd ICT on Section A) and by 2x1500MVA, 765/400kV ICTs at Section-B (3rd & 4th ICTs on Section B) along with associated ICT bays	765/400	3	1500	4500
19.	2023-24	WR	Augmentation of 1x500MVA 400/220kV ICT (3rd) at Bhatapara (PG)	400/220	1	500	500
20.	2023-24	WR	Augmentation of 1x500 MVA, 400/220 kV ICT (3rd) at Raigarh(PG) S/s along with associated ICT bays (400& 220kV bay each - 01nos)	400/220	1	500	500
21.	2023-24	WR	Augmentation of transformation capacity at Kallam PS by 2x500MVA, 400/220kV ICTs (3rd & 4th)	400/220	2	500	1000

Sl.No	Timeframe	Region	Transformers	Voltage ratio (kV)	No. of transformer	Rating of transformer (MVA)	Total transformation capacity (MVA)
			along with 220kV bays for RE interconnection				
22.	2023-24	SR	Augmentation of transformation capacity at Hiriyur and Kochi by 1x500 MVA, 400/220 kV ICT	400/220	2	500	1000
23.	2023-24	SR	Establishment of 765/400kV substations at Warangal (New) with 2x1500 MVA transformers	765/400	2	1500	3000
24.	2023-24	SR	Addition of 1x500 MVA, 400/230kV ICTs (4th) at Tuticorin-II GIS sub-station.	400/230	1	500	500
25.	2023-24	SR	Augmentation with 400/220kV, 1x500 MVA Transformer (3rd) at Palakkad (PG) (2x 315 MVA already existing)	400/220	1	500	500
26.	2023-24	SR	Augmentation with 400/220 kV, 1x500 MVA Transformer (3rd) at Kolar (PG) (2x 500 MVA already existing)	400/220	1	500	500
27.	2023-24	SR	Augmentation with 765/400 kV, 1x1500 MVA Transformer (3rd) at Nizamabad (PG) (2x 1500 MVA already existing)	765/400	1	1500	1500
28.	2023-24	SR	Establishment of 5x500 MVA, 400/220 kV pooling station near Munirabad /suitable location in Koppal distt	400/220	5	500	2500
29.	2023-24	SR	Establishment of 400/220 kV, 2x500 MVA Gadag Pooling Station	400/220	2	500	1000
30.	2023-24	SR	Establishment of 2x500 MVA, 400/230 kV Karur Pooling Station	400/230	2	500	1000

Sl.No	Timeframe	Region	Transformers	Voltage ratio (kV)	No. of transformer	Rating of transformer (MVA)	Total transformation capacity (MVA)
31.	2023-24	SR	Augmentation of transformation capacity at Tuticorin-III by 1x500 MVA, 400/230 kV ICT (5th)	400/230	1	500	500
32.	2023-24	SR	Augmentation of transformation capacity at Pavagada by 1x500 MVA, 400/220 kV ICT (6th)	400/220	1	500	500
33.	2023-24	SR	Augmentation of transformation capacity at Arasur by 1x500 MVA, 400/230 kV ICT (4th)	400/230	1	500	500
34.	2023-24	SR	Augmentation of transformation capacity at Hosur by 1x500 MVA, 400/230 kV ICT (4th)	400/230	1	500	500
35.	2023-24	NR	Augmentation with 765/400 kV, 1x1500 MVA Transformer (5th) at Fatehgarh-II PS (1500MVA)	765/400	1	1500	1500
36.	2023-24	NR	Augmentation with 765/400 kV, 1x1500 MVA Transformer (6th) at Fatehgarh-II PS (1500MVA)	765/400	1	1500	1500
37.	2023-24	NR	Augmentation with 400/220 kV, 4x500 MVA Transformer (6th to 9th) at Fatehgarh-II PS with suitable Bus sectionalisation at 400 and 220 kV level and 7 nos. of 220 kV line bays (2000MVA)	400/220	4	500	2000
38.	2023-24	NR	Augmentation with 400/220kV, 3x500MVA Transformer (6th to 8th) at Bhadla-II PS with suitable Bus sectionalisation at 400 and 220 kV level and 5 nos. of 220 line bays (1500MVA)	400/220	3	500	1500
39.	2023-24	NR	Augmentation with 765/400 kV, 1x1500 MVA transformer (4th) at Bhadla-II PS (1500MVA)	765/400	1	1500	1500

Sl.No	Timeframe	Region	Transformers	Voltage ratio (kV)	No. of transformer	Rating of transformer (MVA)	Total transformation capacity (MVA)
40.	2023-24	NR	Establishment of 400/220 kV, 4x500 MVA at Ramgarh – II PS	400/220	4	500	2000
41.	2023-24	NR	Establishment of 765/400 kV, 2x1500 MVA at Sikar – II	765/400	2	1500	3000
42.	2023-24	NR	1x 500 MVA, 400/220 kV ICT at Kurukshetra (PG) S/s	400/220	1	500	500
43.	2023-24	NR	1x 500 MVA, 400/220 kV ICT at Patiala (PG) S/s	400/220	1	500	500
44.	2023-24	NR	Shifting and installation of 400/220 kV, 315 MVA ICT at Bhinmal (PG) S/s spared from Ludhiana (PG)	400/220	1	315	315
45.	2023-24	NR	Establishment of 765/400 kV, 3x1500 MVA GIS substation at Narela	765/400	3	1500	4500
46.	2023-24	NR	Augmentation with 400/220kV, 1x500MVA Transformer at Fatehgarh-2 PS (6th ICT at Section-1 with cable/GIS duct connection at 220kV side)	400/220	1	500	500
47.	2023-24	NR	Augmentation with 400/220kV, 1x500MVA Transformer at Bikaner PS (3rd ICT)	400/220	1	500	500
48.	2023-24	NER	Establishment of new 220/132kV, 2x160MVA substation at Nangalbibra	220/132	2	160	320
49.	2024-25	WR	Establishment of 765/400 kV, 4x1500MVA, KPS2 (GIS)	765/400	4	1500	6000

Sl.No	Timeframe	Region	Transformers	Voltage ratio (kV)	No. of transformer	Rating of transformer (MVA)	Total transformation capacity (MVA)
50.	2024-25	WR	Augmentation of Khavda PS1 by 765/400 kV transformation capacity * (max. upto 4x1500 MVA)	765/400	4	1500	6000
51.	2024-25	WR	Establishment of 3x500 MVA, 400/220 kV Pooling Station at Chhatarpur	400/220	3	500	1500
52.	2024-25	WR	Creation of 220kV level (GIS) at 765/400kV Shikrapur (PGCIL) (GIS) Substation with 2x500MVA, 400/220kV ICTs and 4 nos. of 220kV line bays.	400/220	2	500	1000
53.	2024-25	WR	Creation of 220 kV level (GIS) at 765/400 kV Raipur Pool S/s with Installation of 2x500 MVA, 400/220 kV ICTs along with associated ICT bays (220kV-GIS)	400/220	2	500	1000
54.	2024-25	WR	Augmentation of 1x500 MVA, 400/220 kV ICT at Raipur Pool S/s along with associated ICT bays (220kV-GIS)	400/220	1	500	500
55.	2024-25	WR	Creation of 220 kV level at 765/400 kV Dharamjaigarh S/s with Installation of 2x500 MVA, 400/220 kV ICTs along with associated ICT bays	400/220	2	500	1000
56.	2024-25	WR	Establishment of 765/400 kV, 3x1500 MVA, KPS3 (GIS) with 1x330 MVAR 765 kV bus reactor and 1x125 MVAR 400 kV bus reactor.	765/400	3	1500	4500
57.	2024-25	WR	Establishment of 3x1500 MVA, 765/400 kV Ahmedabad S/s	765/400	3	1500	4500
58.	2024-25	WR	Augmentation of 765/400 kV Navsari (new) (South Gujarat) S/s (GIS)	765/400	1	1500	1500
59.	2024-25	WR	Augmentation of transformation capacity at Banaskantha 765/400 kV S/s by 1x1500 MVA ICT	765/400	1	1500	1500
60.	2025-26	WR	Establishment of 400/220 kV, 3x500 MVA at Solapur PP (near Mohol)	400/220	4	500	2000

Sl.No	Timeframe	Region	Transformers	Voltage ratio (kV)	No. of transformer	Rating of transformer (MVA)	Total transformation capacity (MVA)
61.	2024-25	WR	Creation of 220 kV level at 765/400 kV Jabalpur PS with Installation of 2x500 MVA, 400/220 kV ICTs along with associated ICT bays	400/220	2	500	1000
62.	2024-25	WR	Installation of 1x500 MVA, 400/220 kV ICT (4th) along with associated ICT bays at Satna(PG)	400/220	1	500	500
63.	2024-25	WR	Augmentation of transformation capacity at Pune (GIS) 765/400 kV substation by 1x1500 MVA ICT (3 rd)	765/400	1	1500	1500
64.	2025-26	WR	Establishment of 4x500 MVA, 400/220kV ICTs in pooling station near Dhule, Maharashtra.	400/220	4	500	2000
65.	2024-25	WR	765/400 kV, 2x1500 MVA ICT augmentation (3rd & 4th on Bus Section-I) at KPS2 765/400 kV, 1x1500 MVA ICT augmentation (3rd on Bus Section-II) at KPS2	765/400	3	1500	4500
66.	2024-25	SR	Establishment of 2x500MVA, 400/220 kV GIS substation at Kasargode	400/220	2	500	1000
67.	2024-25	SR	Augmentation of 400/220 kV, 3x500 MVA Gadag Pooling Station	400/220	3	500	1500
68.	2024-25	SR	Augmentation of 3x500 MVA, 400/230 kV at Karur PS	400/230	3	500	1500
69.	2024-25	SR	Upgradation of Narendra (New) (GIS) to its rated voltage of 765kV level alongwith 4x1500 MVA, 765/400kV ICTs and 2x330 MVAr Bus Reactor	765/400	4	1500	6000
70.	2024-25	SR	Establishment of 2x1500 MVA, 765/400 KV Pooling station at suitable location in Kurnool Distt. (Kurnool-III)	765/400	2	1500	3000
71.	2024-25	SR	Establishment of 5x500 MVA 400/220kV Pooling station at suitable location in Kurnool Distt. (Kurnool-III)	400/220	5	500	2500

Sl.No	Timeframe	Region	Transformers	Voltage ratio (kV)	No. of transformer	Rating of transformer (MVA)	Total transformation capacity (MVA)
72.	2024-25	SR	Augmentation of transformation capacity by 1x1500 MVA, 765/400 KV at Kurnool-III Pooling Station (in matching time frame of Kurnool Part-B)	765/400	1	1500	1500
73.	2024-25	SR	Augmentation of transformation capacity by 4x500 MVA 400/220kV at Kurnool-III Pooling Station (in matching time frame of Kurnool Part-B)	765/400	4	500	2000
74.	2024-25	SR	Augmentation of transformation capacity at Mysore by 1x500 MVA, 400/220 kV ICT (4th)	400/220	1	500	500
75.	2024-25	NR	Augmentation with 1x500MVA, 400/220kV transformer (3rd) at 400/220kV Jind (PG) S/s	400/220	1	500	500
76.	2024-25	NR	Establishment of 2x500 MVA 400/220 kV pooling station at Fatehgarh-4 along with 2x125 MVA Bus Reactor	400/220	2	500	1000
77.	2024-25	NR	Augmentation of 3x500 MVA 400/220 kV pooling station at Fatehgarh-4	400/220	3	500	1500
78.	2024-25	NR	Establishment of 2x1500 MVA 765/400kV at Bhadla-3	765/400	2	1500	3000
79.	2024-25	NR	3x500 MVA 400/220 kV pooling station at Bhadla-3	400/220	3	500	1500
80.	2024-25	NR	Augmentation of 7x500 MVA 400/220 kV transformation capacity at Bhadla-3	400/220	7	500	3500
81.	2024-25	NR	Establishment of 2x1500 MVA 765/400kV at Ramgarh	765/400	2	1500	3000
82.	2024-25	NR	2x500 MVA 400/220 kV pooling station at Ramgarh	400/220	2	500	1000
83.	2024-25	NR	Augmentation of 1x1500 MVA 765/400kV at Ramgarh PS	765/400	1	1500	1500
84.	2024-25	NR	Establishment of 3x1500 MVA 765/400kV at Fatehgarh-3(new section)	765/400	3	1500	4500
85.	2024-25	NR	3x500 MVA 400/220 kV pooling station at Fatehgarh-3(new section)	400/220	3	500	1500

Sl.No	Timeframe	Region	Transformers	Voltage ratio (kV)	No. of transformer	Rating of transformer (MVA)	Total transformation capacity (MVA)
86.	2024-25	NR	Augmentation of 3x1500 MVA 765/400kV at Fatehgarh-3(new section)	765/400	3	1500	4500
87.	2024-25	NR	2x500 MVA 400/220 kV pooling station at Fatehgarh-3(new section)	400/220	2	500	1000
88.	2024-25	NR	Establishment of 2x1500MVA 765/400kV Substation at suitable location near Beawar	765/400	2	1500	3000
89.	2024-25	NR	Establishment of 2x1500 MVA 765/400kV substation at suitable location near Dausa	765/400	2	1500	3000
90.	2024-25	NR	Augmentation with 400/220kV, 1x500MVA Transformer (10th) at Fatehgarh-2 PS	765/400	1	1500	1500
91.	2024-25	NR	Augmentation with 765/400kV, 1x1500MVA Transformer (5th) at Bhadla-2 PS	765/400	1	1500	1500
92.	2024-25	NR	Augmentation with 765/400kV, 1x1500MVA Transformer (3rd) at Bikaner (PG)	765/400	1	1500	1500
93.	2024-25	NR	Augmentation of 1x1500 MVA ICT (3rd), 765/400kV ICT at Jhatikara Substation (Bamnoli/Dwarka section)	765/400	1	1500	1500
94.	2024-25	NR	Augmentation with 1x500MVA, 400/220kV transformer (3rd) at 400/220kV Bahadurgarh (PG) S/s	400/220	1	500	500
95.	2024-25	NR	Replacement of 1x315 MVA 400/220kV ICT (ICT-1) at 400/220 kV Ludhiana (PG) S/s with 1x500 MVA 400/220kV ICT	400/220	1	185	185
96.	2024-25	NR	Replacement of 1x250 MVA, 400/220 kV ICT to 500 MVA at 765/400/220 kV Moga (PG) S/s along with associated works at 220 kV level	400/220	1	250	250
97.	2024-25	NR	Augmentation of Transformation Capacity by 1x500 MVA, 400/220kV ICT (3rd) at 400/220 kV Patran (GIS) S/s	400/220	1	500	500

Sl.No	Timeframe	Region	Transformers	Voltage ratio (kV)	No. of transformer	Rating of transformer (MVA)	Total transformation capacity (MVA)
98.	2024-25	ER	400/220kV, 2x500MVA ICTs along with associated bays (220kV bays in GIS and 400kV bays in AIS) at Banka	400/220	2	500	1000
99.	2024-25	ER	Installation of existing spare 132/66kV, 1x50MVA ICT (already stationed at Gangtok) as 3rd ICT at Gangtok (POWERGRID) S/s along with conversion of existing 132kV TBC bay as 132kV ICT bay for 3rd ICT and construction of new 66kV ICT bay in Hybrid/Outdoor GIS with suitable modification in the gantry structure of 66kV side	132/66	1	50	50
100.	2025-26	WR	Establishment of 4x500MVA, 400/220kV ICTs at Lakadia (GIS) PS	400/220	4	500	2000
101.	2025-26	WR	Additional 1x500MVA 400/220kV (9th) ICT, for injection from any additional RE project (other than 4000MW injection under SECI bids upto Tranche IV) in existing Bhuj PS with associated 400 kV GIS bay and 220kV AIS bay.	400/220	1	500	500
102.	2025-26	WR	Establishment of 400/220 kV, 5x500 MVA at Wardha SEZ PP	400/220	5	500	2500
103.	2025-26	WR	Establishment of 3x1500MVA, 765/400kV at Dholera PS	765/400	3	1500	4500
104.	2025-26	WR	Establishment of 765/400 kV, 2x1500 MVA at Karera (near Datiya)	765/400	2	1500	3000
105.	2025-26	WR	Establishment of 400/220 kV, 2x500 MVA ICTs at Karera (near Datiya)	400/220	2	500	1000
106.	2025-26	WR	Establishment of 765/400 kV, 2x1500 MVA ICTs at Ishanagar (New)	765/400	2	1500	3000
107.	2025-26	WR	Establishment of 400/220 kV, 2x500 MVA ICTs at Ishanagar (New)	400/220	2	500	1000
108.	2025-26	WR	Installation of 3x1500MVA, 765/400kV at Mandasaur PS + 1	765/400	3	1500	4500

Sl.No	Timeframe	Region	Transformers	Voltage ratio (kV)	No. of transformer	Rating of transformer (MVA)	Total transformation capacity (MVA)
			spare unit of 500MVA 765/400kV ICT				
109.	2025-26	WR	Installation of 5x500MVA, 400/220kV at Mandasaur PS	400/220	5	500	2500
110.	2025-26	WR	400/220 kV, 3x500 MVA ICT augmentation (4th 5th & 6th) at Pachora PS	400/220	3	500	1500
111.	2025-26	WR	Establishment of 765/400kV (2x1500MVA) at Kurawar	765/400	2	1500	3000
112.	2025-26	WR	Establishment of 3x1500MVA 765/400kV Transformers at Boisar-II (GIS) S/s	765/400	3	1500	4500
113.	2025-26	WR	Establishment of 2x500MVA 400/220kV transformers at Boisar-II (GIS) S/s	400/220	2	500	1000
114.	2025-26	WR	Establishment of 2x1500MVA 765/400kV transformers at Pune-III	765/400	2	1500	3000
115.	2025-26	WR	Establishment of 3x500MVA, 400/220kV transformers at PuneIII	400/220	3	500	1500
116.	2025-26	WR	Augmentation of transformation capacity at KPS1(GIS) by 1x1500MVA, 765/400kV ICT (8th)	765/400	1	1500	1500
117.	2025-26	WR	Augmentation of transformation capacity at KPS2(GIS) by 1x1500MVA, 765/400kV ICT (8th) on Bus section-II	765/400	1	1500	1500
118.	2025-26	WR	Augmentation of transformation capacity at KPS3(GIS) by 1x1500MVA, 765/400kV ICT (4th) on Bus section-I	765/400	1	1500	1500
119.	2025-26	WR	Establishment of 4x1500 MVA, 765/400 kV at Navinal (Mundra) S/s (GIS)	765/400	4	1500	6000
120.	2025-26	SR	Establishment of 3x1500MVA (765/400kV) Bidar PS	765/400	3	1500	4500

Sl.No	Timeframe	Region	Transformers	Voltage ratio (kV)	No. of transformer	Rating of transformer (MVA)	Total transformation capacity (MVA)
121.	2025-26	SR	Establishment of 5x500MVA (400/220kV) Bidar PS	400/220	5	500	2500
122.	2025-26	SR	Establishment of 400/220 kV, 7x500 MVA, Ananthpuram pooling station at suitable border location between Anantapur & Kurnool Distt	400/220	7	500	3500
123.	2025-26	SR	Upgradation of Tuticorin PS to its rated voltage of 765kV level alongwith 2x1500 MVA, 765/400kV ICTs and 1x330 MVar Bus Reactor	765/400	2	1500	3000
124.	2025-26	SR	Upgradation of Dharmapuri (Salem New) to its rated voltage of 765kV level alongwith 2x1500 MVA, 765/400kV ICTs and 1x240 MVar Bus Reactor	765/400	2	1500	3000
125.	2025-26	SR	Upgradation of Madhugiri (Tumkur) to its rated voltage of 765kV level alongwith 2x1500 MVA, 765/400kV ICTs and 1x240 MVar Bus Reactor	765/400	2	1500	3000
126.	2025-26	SR	Establishment of 765/400kV , 2X1500 MVA transformer at Koppal-II	765/400	2	1500	3000
127.	2025-26	SR	Establishment of 400/220kV , 2X500 MVA transformer at Koppal-II	400/220	2	500	1000
128.	2025-26	SR	Establishment of 400/220kV , 2X500 MVA transformer at Gadag-II	400/220	2	500	1000
129.	2025-26	SR	Augmentation of transformation capacity at Koppal-II with 765/400kV , 2X1500 MVA transformers	765/400	2	1500	3000
130.	2025-26	SR	Augmentation of transformation capacity at Koppal-II with 400/220kV , 2X500 MVA transformers	400/220	2	500	1000
131.	2025-26	SR	Augmentation of transformation capacity at Maheshwaram by 1x1500 MVA, 765/400 kV ICT (3rd)	765/400	1	1500	1500
132.	2025-26	SR	Establishment of 400/220kV 3x500 MVA Pooling Station near Davangere/Chitradurga	400/220	3	500	1500

Sl.No	Timeframe	Region	Transformers	Voltage ratio (kV)	No. of transformer	Rating of transformer (MVA)	Total transformation capacity (MVA)
133.	2025-26	SR	Establishment of 400/220kV 4x500 MVA Tumkur-II Pooling Station	400/220	4	500	2000
134.	2025-26	SR	Establishment of 400/220kV 2x500 MVA Bijapur Pooling Station	400/220	2	500	1000
135.	2025-26	SR	Establishment of 765/400kV 4x1500 MVA Pooling Station near Nizamabad (Nizamabad-II)	765/400	4	1500	6000
136.	2025-26	SR	Establishment of 400/220kV 2x500 MVA Pooling Station at Nizamabad-II	400/220	2	500	1000
137.	2025-26	SR	Establishment of 400/220kV 2x500 MVA Medak Pooling Station	400/220	2	500	1000
138.	2025-26	SR	Establishment of 400/220kV 2x500 MVA Rangareddy Pooling Station	400/220	2	500	1000
139.	2025-26	NR	Implementation of 2x200 MVA, 400/132 kV transformer at Kishtwar Pooling Station along with 4 no. of 132 kV line bays	400/132	2	200	400
140.	2025-26	NR	Establishment of 2x315MVA, 400/220kV Siot(Rajouri) S/s with 1x125 MVAR (420 kV) bus reactors	400/220	2	315	630
141.	2025-26	NR	Establishment of 7x105 MVA, 400/220kV Nange GIS Pooling Station	400/220	2	315	630
142.	2025-26	NR	Establishment of 6x1500 MVA, 765/400kV & 5x500 MVA 400/220kV Bikaner-III Pooling Station at a suitable location near Bikaner	765/400	6	1500	9000
143.	2025-26	NR	Establishment of 6x1500 MVA, 765/400kV & 5x500 MVA 400/220kV Bikaner-III Pooling Station at a suitable location near Bikaner	400/220	5	500	2500
144.	2025-26	NR	Establishment of 765/400 kV, 4x1500 MVA Neemrana-II S/s at a suitable location near Neemrana	765/400	4	1500	6000
145.	2025-26	NR	Augmentation with 400/220 kV, 5x500 MVA [^] ICT at Bikaner-II PS	400/220	5	500	2500
146.	2025-26	NR	Augmentation with 765/400 kV, 1x1500MVA ICT (4th) at Bikaner (PG)	765/400	1	1500	1500

Sl.No	Timeframe	Region	Transformers	Voltage ratio (kV)	No. of transformer	Rating of transformer (MVA)	Total transformation capacity (MVA)
147.	2025-26	NR	Augmentation by 400/220 kV, 1x500 MVA (3 rd) ICT at Kotputli (PG)	400/220	1	500	500
148.	2025-26	NR	Establishment of 4x1500 MVA, 765/400 kV & 5x500 MVA, 400/220 kV Fatehgarh- IV (Section-2) Pooling Station	765/400	4	1500	6000
149.	2025-26	NR	Establishment of 4x1500 MVA, 765/400 kV & 5x500 MVA, 400/220 kV Fatehgarh- IV (Section-2) Pooling Station	400/220	5	500	2500
150.	2025-26	NR	Establishment of 4x1500 MVA, 765/400 kV & 5x500 MVA, 400/220 kV Barmer-I Pooling Station	765/400	4	1500	6000
151.	2025-26	NR	Establishment of 4x1500 MVA, 765/400 kV & 5x500 MVA, 400/220 kV Barmer-I Pooling Station	400/220	5	500	2500
152.	2025-26	NR	Establishment of 2x1500 MVA, 765/400 kV Substation at suitable location near Jalore PS	765/400	2	1500	3000
153.	2025-26	NR	Augmentation by 1x1500 MVA, 765/400 kV ICT at Fatehgarh-II PS (7th)	765/400	1	1500	1500
154.	2025-26	NER	Upgradation of existing 132kV Namsai (POWERGRID) S/s to 220kV (with 220kV side as GIS)	220/132	2	160	320
155.	2025-26	NER	400/220kV, 2x500MVA ICTs at Gogamukh	400/220	2	500	1000
156.	2025-26	NER	220/132kV, 2x200MVA ICTs at Gogamukh	220/132	2	200	400
157.	2025-26	ER	Establishment of Paradeep 765/400kV, 2x1500MVA GIS substation	765/400	2	1500	3000
158.	2026-27	WR	Establishment of 8x1500MVA, 765/400kV ICTs at Akola-III(HVDC)	765/400	8	1500	12000
159.	2026-27	WR	Augmentation of transformation capacity at KPS2(GIS) by 1x1500MVA, 765/400kV ICT (9th) on Bus section-I	765/400	1	1500	1500
160.	2026-27	WR	Augmentation of transformation capacity at KPS3(GIS) by	765/400	3	1500	4500

Sl.No	Timeframe	Region	Transformers	Voltage ratio (kV)	No. of transformer	Rating of transformer (MVA)	Total transformation capacity (MVA)
			3x1500MVA, 765/400kV ICT (5th, 6th & 7th) on Bus section-II				
161.	2026-27	SR	Augmentation of transformation capacity at 765/400kV Nizamabad (PG) by 1X1500 MVA (4th) ICT	765/400	1	1500	1500
162.	2026-27	SR	Augmentation of transformation capacity at 400/220kV Bijapur by 1X500 MVA	400/220	1	500	500
163.	2026-27	SR	Augmentation of transformation capacity at 400/220kV Nizamabad-II by 1X500 MVA	400/220	1	500	500
164.	2026-27	SR	Augmentation of transformation capacity at 765/400 kV Nizamabad-II by 2X1500 MVA	765/400	2	1500	3000
165.	2026-27	SR	Augmentation of transformation capacity at 400/220kV Medak by 1X500 MVA	400/220	1	500	500
166.	2026-27	SR	Augmentation of transformation capacity at 400/220kV Rangareddy by 1X500 MVA	400/220	1	500	500
167.	2026-27	SR	Establishment of 400/220kV 3x500 MVA Karimnagar Pooling Station	400/220	3	500	1500
168.	2026-27	SR	Establishment of 400/220kV 4x500 MVA Bellary-II Pooling Station	400/220	4	500	2000
169.	2026-27	SR	Establishment of 765/400kV 4x1500 MVA Kurnool-IV Pooling Station	765/400	4	1500	6000
170.	2026-27	SR	Establishment of 765/400kV 4x1500 MVA Kurnool-IV Pooling Station	400/220	5	500	2500
171.	2026-27	SR	Augmentation of transformation capacity at 765/400kV Kurnool-III by 3X1500 MVA	765/400	3	1500	4500
172.	2026-27	SR	Augmentation of transformation capacity at 400/220kV Anantapur by 3X500 MVA	400/220	3	500	1500
173.	2026-27	SR	Establishment of 765/400kV 4x1500 MVA Anantapur-II Pooling Station	765/400	4	1500	6000

Sl.No	Timeframe	Region	Transformers	Voltage ratio (kV)	No. of transformer	Rating of transformer (MVA)	Total transformation capacity (MVA)
174.	2026-27	SR	Establishment of 400/220kV 5x500 MVA Anantapur-II Pooling Station	400/220	5	500	2500
175.	2026-27	SR	Augmentation of transformation capacity at 765/400kV Anantapur-II by 1X1500 MVA	765/400	1	1500	1500
176.	2026-27	SR	Augmentation of transformation capacity at 400/220kV Anantapur-II by 2X500 MVA	400/220	2	500	1000
177.	2026-27	SR	Augmentation of transformation capacity at 765/400kV Kurnool-IV by 1X1500 MVA	765/400	1	1500	1500
178.	2026-27	SR	Augmentation of transformation capacity at 400/220kV Kurnool-IV by 2X500 MVA	400/220	2	500	1000
179.	2026-27	SR	Establishment of 765/400kV 3x1500 MVA Kadapa-II Pooling Station	765/400	3	1500	4500
180.	2026-27	SR	Establishment of 400/220kV 4x500 MVA Kadapa-II Pooling Station	400/220	4	500	2000
181.	2026-27	NR	Establishment of 3x315 MVA (10x105 MVA single phase units including one spare) \$ 400/132kV Kaza PS (GIS)	400/132	3	315	945
182.	2026-27	NR	Establishment of 5x1500MVA, 765/400KV ICTs at Fatehpur(HVDC)	765/400	5	1500	7500
183.	2026-27	NR	Upgradation of Kishenpur S/s at 765kV level (4x800MVA)	765/400	4	800	3200
184.	2026-27	NR	Establishment of 2x315 MVA (7x105 MVA 1-ph units including a spare unit) 400/220 kV GIS Pooling Station at Jhangi	400/220	2	315	630
185.	2027-28	NR	400/220/33kV, 315 MVA transformer at pang S/s	400/220	2	315	630
186.	2027-28	NR	765/400/33kV, 1500 MVA transformer at Kaithal S/s	765/400	3	1500	4500
187.	2027-28	NR	Augmentation of 765/400kV, 1500 MVA transformer of Bhiwani S/s	765/400	1	1500	1500

3. Bus Reactors

Sl. No.	Time Frame	Region	Bus Reactors	No of reactors	Rating of reactor	Total reactive compensation (MVAR)
1.	2022-23	NR	500 MVAR TCR at Kurushetra	1	500	500
2.	2023-24	WR	Establishment of 1x125MVAR Bus Reactor at Xeldem S/s	1	125	125
3.	2023-24	WR	Establishment of 765kV 1x330MVAR Bus Reactor at Khavda PS1 (KPS1)	1	330	330
4.	2023-24	WR	Establishment of 400kV 1x125MVAR Bus Reactor at Khavda PS1 (KPS1)	1	125	125
5.	2023-24	WR	Establishment of 1x125 MVAR Bus Reactor at Neemuch PS	1	125	125
6.	2023-24	WR	Establishment of 420kV 125 MVAR bus at reactor at Pachora SEZ PP	1	125	125
7.	2023-24	WR	Establishment of 1x125MVAR bus reactor at Kallam PS	1	125	125
8.	2023-24	WR	Establishment of 125MVAR Bus reactor at Vapi / Ambheti (Vapi-II)	1	125	125
9.	2023-24	WR	2x330 MVAR (765kV) bus reactor at Navsari (New) South Gujarat (GIS) S/s	2	330	660
10.	2023-24	WR	125 MVAR (400kV) bus reactor at Navsari (New) South Gujarat (GIS) S/s	1	125	125
11.	2023-24	SR	2X240 MVAR Bus Reactors at Warangal	2	240	480
12.	2023-24	SR	2x125 MVAR, 400 kV bus reactor at Pooling station (near Munirabad /suitable location in Koppal Distt.)	2	125	250
13.	2023-24	SR	1x125 MVAR (400 kV) bus reactor at Gadag PS	1	125	125
14.	2023-24	SR	2x125 MVAR, 400 kV Bus reactors at Karur PS	2	125	250
15.	2023-24	NR	± 600 MVAR STATCOM at Fatehgarh-II substation with 4x125 MVAR MSC, 2x125 MVAR MSR	2	125	250
16.	2023-24	NR	± 600 MVAR STATCOM at Bhadla-II substation with 4x125 MVAR MSC, 2x125 MVAR MSR	2	125	250
17.	2023-24	NR	Establishment of 400/220 kV, 4x500 MVA at Ramgarh – II PS	2	125	250
18.	2023-24	NR	Establishment of 400kV Pooling Station at Biakner-II	2	125	250
19.	2023-24	NR	1x125 MVAR(400 kV) Bus Reactor at Sikar-II	1	125	125
20.	2023-24	NR	2x330 MVAR(765 kV) Bus Reactor at Sikar-II	2	330	660
21.	2023-24	NR	2x330 MVAR(765 kV) Bus Reactor at Narela	2	330	660
22.	2023-24	NR	1x125 MVAR(400 kV) Bus Reactor at Narela	1	125	125
23.	2023-24	NER	2 nos 31.5MVAR Bus reactor at Nangalbibra	2	32	63
24.	2023-24	ER	1x125 MVAR Bus Reactor at Alipurduar (3rd)	1	125	125
25.	2023-24	ER	Installation of 420kV, 1x125MVAR bus reactor along with associated bay at Biharsharif (POWERGRID) S/s in the bus section having 1x80MVAR existing bus reactor.	1	125	125
26.	2023-24	ER	Installation of new 420kV, 1x125MVAR bus reactor along with associated bay at Jamshedpur (POWERGRID) S/s	1	125	125
27.	2024-25	WR	Establishment of 2x330 MVAR 765 kV bus reactor at KPS2	2	330	660

Sl. No.	Time Frame	Region	Bus Reactors	No of reactors	Rating of reactor	Total reactive compensation (MVAR)
28.	2024-25	WR	Establishment of 2x125 MVAR 400 kV bus reactor at KPS2	2	125	250
29.	2024-25	WR	Augmentation of Khavda PS1 with 1x330 MVAR 765 kV bus reactor on 2nd 765 kV bus section	1	330	330
30.	2024-25	WR	Augmentation of Khavda PS1 with 1x125 MVAR 420 kV bus reactor on 2nd 400 kV bus section	1	125	125
31.	2024-25	WR	Establishment of 1X125 MVAR, 420 kV bus reactor at Chhatarpur PS	1	125	125
32.	2024-25	WR	Establishment of 1x330 MVAR 765 kV bus reactor at KPS3(GIS)	1	330	330
33.	2024-25	WR	Establishment of 1x125 MVAR 400 kV bus reactor at KPS3(GIS)	1	125	125
34.	2024-25	WR	Establishment of 1x330 MVAR 765 kV bus reactor at Ahmedabad S/s	1	330	330
35.	2024-25	WR	Establishment of 1x125 MVAR 400 kV bus reactor at Ahmedabad S/s	1	125	125
36.	2025-26	WR	Establishment of 125MVAR, 420kV Bus Reactor at Solapur PP (near Mohol)	1	125	125
37.	2025-26	WR	Establishment of 2x125MVAR, 420kV bus reactors at pooling station near Dhule, Maharashtra.	2	125	250
38.	2024-25	SR	2X63 MVAR bus reactors at Kasargode Ss	2	63	126
39.	2024-25	SR	2x330 MVAR (765kV) bus reactor at Narendra (New) (GIS)	2	330	660
40.	2024-25	SR	1x330 MVAR (765kV) bus reactor at Kurnool-III PS	1	330	330
41.	2024-25	SR	1x125MVAR (400kV) bus reactor at Kurnool-III PS	1	125	125
42.	2024-25	NR	2x25 MVAR, 220kV bus reactors at 220/66kV Drass S/s	2	25	50
43.	2024-25	NR	1x25 MVAR, 220kV bus reactors at 220/66kV Alusteng S/s	1	25	25
44.	2024-25	NR	Establishment of 2x500 MVA 400/220 kV pooling station at Fatehgarh-4 along with 2x125 MVAR Bus Reactor	2	125	250
45.	2024-25	NR	2x330 MVAR(765 kV) Bus Reactor at Bhadla-3	2	330	660
46.	2024-25	NR	2x125 MVAR(400 kV) Bus Reactor at Bhadla-3	2	125	250
47.	2024-25	NR	2x240 MVAR(765 kV) Bus Reactor at Ramgarh	2	240	480
48.	2024-25	NR	2x125 MVAR(400 kV) Bus Reactor at Ramgarh	2	125	250
49.	2024-25	NR	STATCOM at Ramgarh S/s: ± 2x300 MVAR, 4x125 MVAR MSC, 2x125 MVAR MSR	2	125	250
50.	2024-25	NR	STATCOM : ± 2x300 MVAR, 4x125 MVAR MSC, 2x125 MVAR MSR at Fatehgarh-III	2	125	250
51.	2024-25	NR	2x330 MVAR(765 kV) Bus Reactor at Beawar	2	330	660
52.	2024-25	NR	2x125 MVAR(400 kV) Bus Reactor at Beawar	2	125	250
53.	2024-25	NR	2x330 MVAR(765 kV) Bus Reactor at Dausa	2	330	660
54.	2024-25	NR	2x125 MVAR(400 kV) Bus Reactor at Dausa	2	125	250
55.	2024-25	ER	1X125MVAR Bus Reactors at 400kV Durgapur section-A	1	125	125
56.	2025-26	WR	Establishment of 420kV 125 MVAR bus reactor at Wardha SEZ PP	1	125	125

Sl. No.	Time Frame	Region	Bus Reactors	No of reactors	Rating of reactor	Total reactive compensation (MVAR)
57.	2025-26	WR	Establishment of 1x330MVAR, 765kV Bus reactor at Dholera PS	1	330	330
58.	2025-26	WR	Establishment of 1x125MVAR, 400kV Bus reactor at Dholera PS	1	125	125
59.	2025-26	WR	1x330 MVAR 765 kV bus reactor at Karera (near Datiya)+1 spare unit	1	330	330
60.	2025-26	WR	1x330 MVAR , 765 kV Bus reactor with 1 spare unit of 110MVAR at Ishanagar (New)	1	330	330
61.	2025-26	WR	Establishment of 765kV Mandsaur Pooling Station along with 2x330MVAR (765kV) Bus Reactor	2	330	660
62.	2025-26	WR	Establishment of 2x330MVAR 765kV bus reactor at Kurawar	2	330	660
63.	2025-26	WR	Establishment of 1x125MVAR 420kV bus reactor at Kurawar	1	125	125
64.	2025-26	WR	Establishment of 765 kV Halvad switching station with 765 kV, 2x330 MVAR bus reactors [with 110 MVAR & 80 MVAR 765kV single phase reactor (spare unit for bus/line reactors at Halvad)]	2	330	660
65.	2025-26	WR	Establishment of 765 kV switching station near Vataman with 2x330MVAR, 765 kV bus reactor [with 110 MVAR 765 kV single phase reactor (spare unit for bus/line reactor)]	2	330	660
66.	2025-26	WR	Establishment of 2x330MVAR 765kV bus reactor at Boisar II GIS	2	330	660
67.	2025-26	WR	Establishment of 2x125MVAR 420kV bus reactor at Boisar II GIS	2	125	250
68.	2025-26	WR	Establishment of 2x330MVAR 765kV bus reactors at Punelll	2	330	660
69.	2025-26	WR	Establishment of 2x125MVAR 420kV bus reactor at Pune III	2	125	250
70.	2025-26	WR	Establishment of 2x330 MVAR, 765 kV bus reactors at Navinal (Mundra) S/s (GIS)	2	330	660
71.	2025-26	WR	Establishment of 1x125 MVAR, 420 kV bus reactors at Navinal (Mundra) S/s (GIS)	1	125	125
72.	2025-26	WR	Establishment of 2x125MVAR, 420kV bus reactors at Mandsaur	2	125	250
73.	2025-26	SR	1x240 MVAR Bus Reactor at Bidar	1	240	240
74.	2025-26	SR	1x125 MVAR Bus Reactor at Bidar	1	125	125
75.	2025-26	SR	2x125 MVAR (400kV) bus reactor at Anantapur PS	2	125	250
76.	2025-26	SR	1x330 MVAR Bus Reactor at Tuticorin PS	1	330	330
77.	2025-26	SR	1x240 MVAR Bus Reactor at Dharmapuri (Salem New)	1	240	240
78.	2025-26	SR	1x240 MVAR Bus Reactor at Madhugiri (Tumkur)	1	240	240
79.	2025-26	SR	2X330 MVAR Bus Reactors at 765kV Koppal-II	2	330	660
80.	2025-26	SR	2X125 MVAR Bus Reactors at 400kV Koppal-II	2	125	250
81.	2025-26	SR	2X125 MVAR Bus Reactors at 400kV Gadag-II	2	125	250

Sl. No.	Time Frame	Region	Bus Reactors	No of reactors	Rating of reactor	Total reactive compensation (MVAR)
82.	2025-26	SR	2X125MVAR Bus Reactors at 400kV Davangere/Chitradurga	2	125	250
83.	2025-26	SR	2X125MVAR Bus Reactors at 400kV Tumkur-II	2	125	250
84.	2025-26	SR	2X125MVAR Bus Reactors at 400kV Bijapur	2	125	250
85.	2025-26	SR	2X125MVAR Bus Reactors at 400kV Nizamabad-II	2	125	250
86.	2025-26	SR	2X330MVAR Bus Reactors at 765kV Nizamabad-II	2	330	660
87.	2025-26	SR	2X125MVAR Bus Reactors at 400kV Medak	2	125	250
88.	2025-26	SR	2X125MVAR Bus Reactors at 400kV Rangareddy	2	125	250
89.	2025-26	NR	Implementation of 2x200 MVA, 400/132 kV transformer at Kishtwar Pooling Station along with 4 no. of 132 kV line bays	1	125	125
90.	2025-26	NR	Establishment of 2x315MVA, 400/220kV Siot(Rajouri) S/s with 1x125 MVAR (420 kV) bus reactors	1	80	80
91.	2025-26	NR	125 MVAR (420kV) Bus Reactor at Nange (GIS) PS (1-Ph units along with one spare unit)	1	125	125
92.	2025-26	NR	125 MVAR (420kV) Bus Reactor at Koldam S/s (1-Ph units along with one spare unit)	1	125	125
93.	2025-26	NR	2X330 MVAR Bus Reactors at 765kV Bikaner-III	2	330	660
94.	2025-26	NR	2X125MVAR Bus Reactors at 765kV Bikaner-III	2	125	250
95.	2025-26	NR	2X330 MVAR Bus Reactors at 765kV Neemrana-2	2	330	660
96.	2025-26	NR	2X125MVAR Bus Reactors at 765kV Neemrana-2	2	125	250
97.	2025-26	NR	2X240MVAR Bus Reactors at 765kV Fatehgarh-IV (Section-2)	2	240	480
98.	2025-26	NR	2X125MVAR Bus Reactors at 765kV Fatehgarh-IV (Section-2)	2	125	250
99.	2025-26	NR	2X240MVAR Bus Reactors at 765kV Barmer-I PS	2	240	480
100.	2025-26	NR	2X125MVAR Bus Reactors at 400kV Barmer-I PS	2	125	250
101.	2025-26	NR	2X240MVAR Bus Reactors at 765kV Jalore PS	2	240	480
102.	2025-26	NR	2X125MVAR Bus Reactors at 400kV Jalore PS	2	125	250
103.	2025-26	NER	2x125 MVAR, 400 kV Bus reactors at Gogoamukh	2	125	250
104.	2025-26	NER	1 no 50MVAR Bus reactor at Namsai	1	50	50
105.	2025-26	ER	2X125MVAR Bus Reactors at 400kV Paradeep GIS substation	2	125	250
106.	2025-26	ER	2X330MVAR Bus Reactors at 765kV Paradeep GIS substation	2	330	660
107.	2026-27	WR	Establishment of 2x330 MVAR 765kV bus reactors at Akola-III (HVDC)	2	330	660
108.	2026-27	WR	Establishment of 2x125MVAR, 420kV bus reactors at Akola-III (HVDC)	2	125	250
109.	2026-27	SR	2X125MVAR Bus Reactors at 400kV karimnagar	2	125	250
110.	2026-27	SR	2X125MVAR Bus Reactors at 400kV Bellary-II	2	125	250
111.	2026-27	SR	2X125MVAR Bus Reactors at 400kV Kurnool-IV	2	125	250
112.	2026-27	SR	2X330MVAR Bus Reactors at 765kV Kurnool-IV	2	330	660
113.	2026-27	SR	2X330MVAR Bus Reactors at 765kV Anantapur-II	2	330	660
114.	2026-27	SR	2X125MVAR Bus Reactors at 400kV Anantapur-II	2	125	250
115.	2026-27	SR	2X330MVAR Bus Reactors at 400kV Kadapa-II	2	330	660

Sl. No.	Time Frame	Region	Bus Reactors	No of reactors	Rating of reactor	Total reactive compensation (MVAR)
116.	2026-27	SR	2X125MVAR Bus Reactors at 400kV Kadapa-II	2	125	250
117.	2026-27	NR	2x80 MVAR (420kV) Bus Reactors at Kaza PS	2	80	160
118.	2026-27	NR	2x330MVAR (765kV) bus reactor at Fatehpur	2	330	660
119.	2026-27	NR	1X125MVAR Bus Reactors at 400kV Jhangi	1	125	125

4. Other Schemes

Sl. No.	Time Frame	Region	Scope (each element as separate row)	Voltage ratio (kV)
1.	2022-23	SR	NGR bypass arrangement to use switchable line reactors (240 MVAR each) as bus reactors installed on each circuit of Vemagiri – Chilkaluripeta 765 kV D/c line	765
2.	2022-23	SR	NGR bypass arrangement at Chilkaluripeta to use switchable line reactors (240 MVAR each) as bus reactors installed on each circuit of Chilkaluripeta – Cuddapah 765 kV D/c line and Vemagiri-Chilkaluripeta 765kV D/c line	765
3.	2022-23	NR	1 no. of 220kV line bay at Roorkee	220
4.	2022-23	NR	<p>At Kanpur 12 Ohm Series Line reactor on Kanpur (old)–Kanpur (new) 400 kV D/c line at Kanpur (old) end Fatehpur–Kanpur (old) 400kV D/c and Kanpur (old)-Panki 400kV D/c lines to be disconnected at Kanpur (old) end and connecting them directly to form Fatehpur-Panki 400 kV D/c line</p> <p>At Bhiwani and Hissar 12 Ohm Series Bus reactor at Bhiwani (PG) substation. Out of two 400kV D/c lines between Mohindergarh & Bhiwani, one 400 kV D/c line is owned by Adani and other is under implementation by POWERGRID. It is proposed that Mohindergarh–Bhiwani (PG) 400kV D/c line of POWERGRID and Bhiwani (PG)-Hissar (PG) 400kV D/c line to be by-passed at Bhiwani (PG) end so as to form direct Mohindergarh–Hissar 400kV D/c line of POWERGRID.</p> <p>iii) Remaining Bhiwani (PG)–Hissar (PG) 400kV D/c line (one circuit via Bhiwani (BBMB)) and Hissar (PG)–Moga (One circuit via Fatehabad) 400kV line is to be by-passed at Hissar end so as to form Bhiwani (PG)–Moga 400kV D/c direct line with following arrangement: o One Circuit of Bhiwani (PG) – Moga(PG) 400 kV line(via Hissar) o One Circuit of Bhiwani (PG) – Bhiwani (BBMB) – Fatehabad – Moga(PG) 400 kV line (via Hissar).</p>	400
5.	2022-23	NR	2 nos. of 400kV line bays at Koteshwar	400
6.	2022-23	NER	Re-conductoring of Siliguri – Bongaigaon 400kV D/c line along with suitable modification in line bays equipment at both ends	400
7.	2022-23	NER	Re-conductoring of Alipurduar – Salakati 220kV D/c line along with suitable modification in line bays equipment at both ends	220
8.	2022-23	NER	Re-conductoring of BTPS – Salakati 220kV D/c line along with suitable modification in line bays equipment at both ends	220
9.	2022-23	NER	Re-conductoring of Dimapur – Imphal 132kV S/c line along with suitable modification in line bays equipment at both ends	132
10.	2022-23	NER	Re-conductoring of Loktak – Jiribam 132kV S/c line along with suitable modification in line bays equipment at both ends	132

Sl. No.	Time Frame	Region	Scope (each element as separate row)	Voltage ratio (kV)
11.	2022-23	NER	Conversion of 132kV level of 400/132kV Imphal S/s to Double Main Transfer Bus Scheme preferably with Bus Sectionalisation on AIS depending on layout or alternatively on GIS/ Hybrid GIS if layout does not permit AIS Bus sectionalisation	132
12.	2022-23	NER	Conversion of 132kV level of 132/33kV Nirjuli S/s to Double Main Transfer Bus Scheme preferably with Bus Sectionalisation on AIS depending on layout or alternatively on GIS/ Hybrid GIS if layout does not permit AIS Bus sectionalisation	132
13.	2022-23	ER	Shifting of 400kV side of 400/220kV, 315MVA ICT-I from Durgapur-A section to Durgapur-B section without physical shifting of ICT such that all three ICTs are on same 400kV bus section (if required, GIS bus duct could be used)	400
14.	2022-23	ER	Modification of 132kV SMT bus scheme to DM bus scheme in GIS and 2 no additional 132kV GIS line bays at Malda (400/220/132kV)	132
15.	2023-24	WR	400kV Wardha Sub--station extension (400kV Bus splitting at Wardha SS)	400
16.	2023-24	WR	Splitting of 400 kV bus at 765/400/220 kV Indore S/s into two sections (A&B) through 400kV Bus Sectionalizer bays (GIS) & GIS Bus duct (as per schematic given above)	400
17.	2023-24	WR	Conversion of 50MVAR fixed Line Reactors on each ckt of Parli (PG) – Pune (GIS) 400kV D/c line at Parli (PG) end into switchable.	400
18.	2023-24	WR	1 number of 400kV bay at Solapur (PG) for St-II connectivity to M/s Toramba	400
19.	2023-24	WR	Conversion of 2x240MVAR non-switchable line reactors at Raipur PS (associated with Raipur PS – Champa PS 765kV circuits 1 & 2) into Switchable line reactors along with NGR bypass arrangement	765
20.	2023-24	WR	Bypassing of Parli(PG) – Parli(M) 400kV D/c line (~5km.) and Parli(PG) – Parli(New) 400kV D/c (quad) line (~18km.) at Parli(PG) S/s at outskirts of the Parli(PG) S/s so as to form Parli(M) – Parli(New) 400kV D/c direct line	400
21.	2023-24	WR	Reconductoring of Parli(PG) – Parli(M) 400kV D/c line section of above line (at Sl. 1) with twin HTLS conductor with a minimum capacity of 1940MVA per circuit at a nominal voltage	400
22.	2023-24	WR	400kV Bay Upgradation work at Parli(M) S/s (Parli(M) S/s has a DMT scheme. The current rating of existing bays is 2000A which would be upgraded to 3150A to suit the reconductoring with Twin HTLS conductor)	400
23.	2023-24	WR	1 no. 220kV line bay at Bhuj PS associated with M/s NTPC Renewable Energy Ltd. (300MW)	220
24.	2023-24	SR	One spare unit (1-Ph) of 80 MVAR reactor each at 765 kV Warangal New and Chilikaluripeta substation	765
25.	2023-24	SR	1 no. of 400 kV bay at 765/400 kV Kurnool (New)	400
26.	2023-24	NR	1 no. of 220 kV line bay at 400/220 kV Amritsar(PG) S/s (for 220kV Amritsar (PG) – Rashiana line)	220
27.	2023-24	NR	4 nos. of 220 kV line bay at at 400/220 kV Jind (PG) S/s	220
28.	2023-24	NR	Installation of 50 MVAR switchable line reactor at Mainpuri end and fixed 50 MVAR line reactor at Ballabgarh end on 400 kV Mainpuri- Ballabgarh D/c line	400
29.	2023-24	NR	Installation of 50 MVAR switchable line reactor at Allahabad end on 400 kV Kanpur- Allahabad S/c line	400
30.	2023-24	NR	Installation of fixed 50 MVAR line reactor at Bhiwadi end for uncompensated circuit of 400 kV Agra- Bhiwadi D/c line	400

Sl. No.	Time Frame	Region	Scope (each element as separate row)	Voltage ratio (kV)
31.	2023-24	NER	Reconductoring of Loktak (NHPC) – Imphal (POWERGRID) 132kV S/c line with HTLS conductor (with Ampacity of single HTLS as 800A at nominal voltage) along with strengthening of associated structure in NHPC switchyard, if necessary	132
32.	2023-24	NER	Replacement of existing CT of 600-400-200/1A at Loktak HEP end in Loktak – Imphal 132kV S/c line with rating commensurate with ampacity (800A) of HTLS conductor	132
33.	2023-24	ER	Installation of new 420kV, 1x63MVAR line reactor at Maithon-A end of Maithon-A – Kahalgaon-B ckt-1 400kV line along with new 700ohm NGR (with NGR bypass arrangement for operation of line reactor as a bus reactor	400
34.	2024-25	WR	4 No. of 220 kV line bays at Jabalpur PS for LILO of Narsinghpur - Jabalpur (MP) 220 kV D/c line at Jabalpur Pool	220
35.	2024-25	WR	2 No. of 220kV line bays at Satna for LILO of Satna 220kV - Maihar 220kV line at Satna (PG) S/s	220
36.	2024-25	WR	220kV bus extension (GIS) of Rajgarh 400/220 kV (PG) S/s along with 220kV Bus Coupler bay for extended bus.	220
37.	2024-25	WR	220kV bus sectionaliser bay (GIS) between existing & extended 220 kV bus of Rajgarh S/s.	220
38.	2024-25	WR	220kV GIS line bay at Rajgarh 400/220 kV (PG) S/s (on extended bus) for RE interconnection.	220
39.	2024-25	SR	Implementation of 2 no. of 220 kV bays at Pavagada PS under ISTS	220
40.	2024-25	SR	2 Nos. of 220 kV bays at 400/220 kV Panchkula (Barwala) S/s	220
41.	2024-25	NR	1 no. of 400 kV line bay at Rampura (Kashipur) S/s	400
42.	2024-25	NR	Upgradation of existing 400kV bays at Khandukhal (Srinagar)	400
43.	2024-25	NR	Upgradation of existing 1 no. of 400 kV diameter comprising line bay (Srinagar) and ICT bay alongwith associated Tie bay at Rampura (Kashipur)	400
44.	2024-25	NR	2 nos of 220 kV line bays at 400/220 kV Bahadurgarh (PG) S/s	220
45.	2024-25	NR	2 nos of 220 kV line bays at 400/220 kV Bahadurgarh (PG) S/s	220
46.	2024-25	NR	2 nos of 220 kV line bays at 400/220 kV Sonapat (PG) S/s	220
47.	2024-25	NR	Reconductoring of 400 kV Jodhpur (Surpura)(RVPN) – Kankroli S/c (twin moose) line with twin HTLS conductor	400
48.	2024-25	NR	Bypassing of 400 kV Kankroli - BhinmalZerda line at Bhinmal to form 400 kV Kankroli – Zerda (direct) line	400
49.	2024-25	NER	Reconductoring of existing Single ACSR Panther Kopili (NEEPCO) – Khandong (NEEPCO) 132kV S/c line-1 (10.9km) of POWERGRID with Single HTLS conductor of ampacity of 800A (at nominal voltage level & considering 40°C ambient temp.) along with replacement of existing wave trap at Kopili end and CT at Khandong end with rating commensurate with ampacity (800A) of HTLS conductor.	132
50.	2024-25	NER	Reconductoring of existing Single ACSR Panther Khandong (NEEPCO) – Khliehriat (POWERGRID) 132kV S/c line-1 (42.48km) of POWERGRID with Single HTLS conductor of ampacity of 800A (at nominal voltage level & considering 40°C ambient temp.) along with replacement of existing CTs at both ends with rating commensurate with ampacity (800A) of HTLS conductor.	132

Sl. No.	Time Frame	Region	Scope (each element as separate row)	Voltage ratio (kV)
51.	2024-25	NER	Reconductoring of existing Single AAAC Panther Khandong (NEEPCO) – Khliehriat (POWERGRID) 132kV S/c line-2 (40.93km) of POWERGRID with Single HTLS conductor of ampacity of 800A (at nominal voltage level & considering 40°C ambient temp.) along with replacement of existing CTs at both ends & wave trap at Khandong end with rating commensurate with ampacity (800A) of HTLS conductor, and strengthening of requisite tower members (approx. 0.348 MT).	132
52.	2024-25	NER	Reconductoring of existing Single ACSR Panther Khliehriat (POWERGRID) – Khliehriat (MePTCL) 132kV S/c POWERGRID line-1 (7.8km) of POWERGRID with Single HTLS conductor of ampacity of 800A (at nominal voltage level & considering 40°C ambient temp.) along with replacement of existing CTs at both ends with rating commensurate with ampacity (800A) of HTLS conductor, and strengthening of requisite tower members (approx. 0.121 MT).	132
53.	2024-25	NER	Reconductoring of existing Single AAAC Panther Khliehriat (POWERGRID) – Badarpur (POWERGRID) 132kV S/c line (76.64km) with Single HTLS conductor of ampacity of 900A (at nominal voltage level & considering 40°C ambient temp.) along with replacement of existing CTs at both ends with rating commensurate with ampacity (900A) of HTLS conductor.	132
54.	2024-25	NER	Replacement of existing bus coupler bay CT at Khandong HEP (NEEPCO) switchyard from 600A to 800A	132
55.	2024-25	ER	Creation of 220kV GIS bus at Banka (POWERGRID) S/s	220
56.	2024-25	ER	400kV Bus extension works at Banka (PGCIL) 400/132kV Substation	400
57.	2024-25	ER	Reconductoring of Rango-Gangtok 132kV D/c line	132
58.	2024-25	ER	Construction of new 132kV TBC bay in Hybrid/Outdoor GIS	132
59.	2025-26	WR	Conversion of 1x240 MVar, 765 kV Fixed line reactor at Gwalior end to Switchable line reactor (with NGR bypass arrangement) along with implementation of Inter-tripping scheme	765
60.	2025-26	WR	Conversion of 1x330 MVAR, 765 kV Fixed line reactor at Orai end of Ishanagar – Orai 765 kV line (formed after LILO at Sl. 2) to Bus reactor at Orai S/s	765
61.	2025-26	WR	2 no. of 400 kV line bays at Ujjain (MPPTCL) for Pachora – Ujjain 400kV D/c line	400
62.	2025-26	WR	Installation of 240 MVar 765 kV switchable line reactor on each ckt at Halvad end of Halvad – Ahmedabad 765 kV D/c line (~220 km length)	765
63.	2025-26	WR	Establishment of 765 kV switching station near Vataman	765
64.	2025-26	WR	Conversion of 240 MVar 765 kV switchable line reactor on each ckt at Lakadia end of Lakadia – Ahmedabad 765 kV D/c line (being LILOed at Halvad) into bus reactors with NGR bypassing arrangement.	765
65.	2025-26	WR	Conversion of 330 MVar 765 kV switchable line reactor on each ckt at Vadodara end of Lakadia – Vadodara 765 kV D/c line (being LILOed at Vataman) into bus reactors with NGR bypassing arrangement.	765
66.	2025-26	WR	Creation of 765kV & 400kV bus section-2 at KPS3	765
67.	2025-26	WR	Installation of ±300MVar STATCOM with 1x125 MVar MSC, 2x125 MVar MSR at KPS3 400kV Bus section-2	765

Sl. No.	Time Frame	Region	Scope (each element as separate row)	Voltage ratio (kV)
68.	2025-26	WR	Establishment of 765/400/220kV Boisar-II (GIS) S/s	765
69.	2025-26	WR	Establishment of 765/400/220kV Pune-III (GIS) S/s	765
70.	2025-26	WR	Inter tripping scheme on 330MVar SW LR at Pune(GIS) end of Pune(GIS) – PuneIII(GIS) 765kV D/c line	766
71.	2025-26	WR	± 300MVar STATCOM with 1x125 MVar MSC, 2x125 MVar MSR at KPS1 400kV Bus section-1	400
72.	2025-26	WR	± 300MVar STATCOM with 1x125 MVar MSC, 2x125 MVar MSR at KPS1 400kV Bus section-2	400
73.	2025-26	WR	± 300MVar STATCOM with 1x125 MVar MSC, 2x125 MVar MSR at KPS3 400kV Bus section-1	400
74.	2025-26	WR	± 300MVar STATCOM with 3x125 MVar MSC, 1x125 MVar MSR at 400kV level of Navsari (New)(PG) S/s	400
75.	2025-26	NER	Reconductoring of Melriat (GIS) (POWERGRID) – Zuangtui (Mizoram) 132kV ACSR Panther S/c line with Single HTLS rating of 900A (at nominal voltage level) along with new one (1) 132kV line bay at Melriat (POWERGRID) S/s (of rating commensurate with rating of HTLS viz. 900A) for termination of this HTLS line from existing bay and termination in the new bay	132
76.	2025-26	NER	Replacement of existing CT of 600/1A at Zuangtui (Mizoram) end in Melriat GIS (POWERGRID) – Zuangtui (Mizoram) 132kV S/c line with rating commensurate with ampacity (900A) of HTLS conductor	132
77.	2025-26	NER	Reconductoring of Aizawl (POWERGRID) – Luangmual (Mizoram) 132kV ACSR Panther S/c line with Single HTLS rating of HTLS conductor of 800A (at nominal voltage level) along with upgradation of line bay equipment at Aizawl (POWERGRID) end commensurate with rating of HTLS, as required	132
78.	2025-26	NER	Replacement of existing CT of 600/1A at Luangmual (Mizoram) end in Aizawl (POWERGRID) – Luangmual (Mizoram) 132kV S/c line with rating commensurate with ampacity (800A) of HTLS conductor	132
79.	2025-26	NER	Upgradation of Single Main and Transfer Bus to Double Bus arrangement with GIS at 132kV Khliehriat (POWERGRID) switching station	132
80.	2025-26	NER	Upgradation of Single Main and Transfer Bus to Double Bus arrangement with Green GIS at 132kV Badarpur (POWERGRID) switching station	132
81.	2025-26	ER	Reconductoring of Jharsuguda/Sundargarh (POWERGRID) – Rourkela (POWERGRID) 400kV 2xD/c Twin Moose line with Twin HTLS conductor (with ampacity Single HTLS as 1228A at nominal voltage).	400
82.	2025-26	ER	Bay upgradation at Rourkela (POWERGRID) end for 3150A rating – 04 nos. diameters in one and half breaker scheme (except 09 nos. existing circuit breakers which are of minimum 3150 A rating).	400
83.	2025-26	ER	Extension at Angul (POWERGRID) S/s with 2 no. of 765kV line bays (along with space for future switchable line reactors)	765
84.	2025-26	ER	Extension at Paradeep (OPTCL) GIS S/s with 2 no. of 400kV GIS line bays	400
85.	2026-27	WR	Establishment of 8000 MW, ± 800 kV KPS2 (HVDC) [LCC] terminal station (4x2000 MW) with 400/33 kV, 2x50 MVA transformers for exclusively supplying auxiliary power to HVDC terminal.	800

Sl. No.	Time Frame	Region	Scope (each element as separate row)	Voltage ratio (kV)
86.	2026-27	WR	Establishment of 8000 MW, \pm 800 kV Akola-III (HVDC) [LCC] terminal station (4x2000 MW)	800
87.	2026-27	WR	Establishment of 400/33 kV, 2x50 MVA transformers at KPS2 (HVDC) for exclusively supplying auxiliary power to HVDC terminal.	400

Annex 2.10

Inter-Regional Transmission Capacity (MW)

Transmission Line	Present	Capacity by 2027-28
EAST - NORTH		
Dehri/Sasaram - Sahupuri 220kV S/c	130	130
Sasaram HVDC back-to-back	500	500
Muzaffarpur - Gorakhpur 400kV D/c (with Series Comp.+TCSC)	2000	2000
Patna - Balia 400kV D/c (Quad)	1600	1600
Biharshariff - Balia 400kV D/c (Quad)	1600	1600
Barh/Patna - Balia 400kV D/c (Quad)	1600	1600
Gaya - Balia 765kV S/c	2100	2100
Sasaram bypassing (additional capacity)	500	500
Sasaram - Fatehpur 765kV S/c	2100	2100
Barh-II/Motihari - Gorakhpur 400kV D/c (Quad)	1600	1600
Gaya-Varanasi 765kV 2xS/c	4200	4200
Biharsharif-Varanasi 400kV D/c (Quad)	1600	1600
LILO of Biswanath Chariali - Agra \pm 800kV HVDC Bipole at new pooling station in Alipurduar and addition of 3000MW module	3000	3000
Sub-total	22,530	22,530
EAST - WEST		
Budhipadar-Korba 220kV S/c	130	130
Budhipadar-Korba 220kV D/c	260	260
Rourkela/Jharsuguda - Raigarh/Raipur 400kV D/c (with Series Comp.+TCSC)	1400	1400
Ranchi - Sipat 400 kV D/c with series comp.	1200	1200
Rourkela/Jharsuguda - Raigarh/Raipur 400kV (2nd) D/c (with Series Comp.)	1400	1400
Ranchi - Dharamjayagarh/WR Pooling Station 765kV S/c	2100	2100
Ranchi - Dharamjayagarh 765kV (2nd) S/c	2100	2100
Jharsuguda - Dharamjayagarh 765kV D/c	4200	4200
Jharsuguda - Dharamjayagarh 765kV (2nd) D/c	4200	4200
Jharsuguda - Raipur Pool 765kV D/c	4200	4200
Jeypore - Jagdalpur 400 kV D/c		1600
Sub-total	21,190	22,790

Transmission Line	Present	Capacity by 2027-28
EAST - SOUTH		
Balimela - Upper Sileru 220kV S/c	130	130
Gazuwaka HVDC back-to-back	1000	1000
Talcher - Kolar HVDC bipole	2000	2000
Upgradation of Talcher-Kolar HVDC Bipole	500	500
Angul - Srikakulum 765kV D/c	4200	4200
Sub-total	7,830	7,830
EAST - NORTH EAST		
Birpara/Alipurduar - Salakati 220kV D/c	260	350
Siliguri - Bongaigaon 400kV D/c	1000	1600
Siliguri/Alipurduar - Bongaigaon 400kV D/c (Quad)	1600	1600
Sub-total	2,860	3,550
NORTH EAST - NORTH		
Biswanath Chariali - Agra \pm 800kV HVDC Bipole with 3000MW converter	3000	3000
Sub-total	3,000	3,000
WEST - NORTH		
Auriya - Malanpur 220kV D/c	260	260
Kota - Ujjain 220kV D/c	260	260
Vindhyachal HVDC back-to-back	500	500
Gwalier - Agra 765kV 2xS/c	4200	4200
Zerda - Kankroli 400kV D/c	1000	1000
Gwalior - Jaipur 765kV 2xS/c	4200	4200
Adani (Mundra) - Mahendranagar \pm 500kV HVDC bipole	2500	2500
RAPP - Sujalpur 400kV D/c	1000	1000
Champa Pool - Kurukshetra \pm 800kV HVDC Bipole	4500	4500
Jabalpur - Orai 765kV D/c	4200	4200
LILO of Satna - Gwalior 765kV S/c line at Orai	4200	4200
Upgradation of Champa Pool - Kurukshetra \pm 800kV HVDC Bipole	1500	1500
Banaskantha - Chittorgarh 765kV D/c	4200	4200
Vindhyachal - Varanasi 765kV D/c	4200	4200
Neemuch-Chittorgarh 400 kV D/c		1600
Chittorgarh-Indore 765 kV D/c		4200
Neemuch7 (Mandsaur PS) -Jalore 765 kV D/c		4,200
Neemuch7 (Mandsaur PS) -Beawar 765 kV D/c		4,200

Transmission Line	Present	Capacity by 2027-28
Sub-total	36,720	50,920
WEST - SOUTH		
Chandrapur HVDC back-to-back	1000	1000
Kolhapur - Belgaum 220kV D/c	260	260
Ponda - Nagajhari 220kV D/c	260	260
Raichur - Sholapur 765kV S/c	2100	2100
Raichur - Sholapur 765kV (2nd) S/c	2100	2100
Narendra - Kolhapur 765kV D/c (operated at 400kV)	2200	2200
Wardha - Nizamabad 765kV D/c	4200	4200
Warora Pool - Warangal (New) 765kV D/c	-	4200
Raigarh - Pugulur ±800kV HVDC Bipole	6000	6000
LILO of Narendra - Narendra (New) 400kV (Quad) line at Xeldam (Goa)	-	1600
Narendra-Pune 765 kV D/c	-	4200
Sub-total	18,120	28,120
TOTAL	112,250	138,740
* Barsur (WR) – L. Sileru (SR) 220kV HVDC Monopole of 200MW capacity is currently not in operation.		



**Prepared by
Central Transmission Utility (CTU)**

March 2023